



Designation: ~~D6372—15~~ D6372 – 23

## Standard Practice for Design, Testing, and Construction of Microsurfacing<sup>1</sup>

This standard is issued under the fixed designation D6372; the number immediately following the designation indicates the year of original adoption or, in the case of revision, the year of last revision. A number in parentheses indicates the year of last reapproval. A superscript epsilon ( $\epsilon$ ) indicates an editorial change since the last revision or reapproval.

### 1. Scope

1.1 This practice covers the design, testing, and construction of mixtures of ~~polymer-modified~~ polymer-modified asphalt emulsion, mineral aggregate, mineral filler, water, and other additives, properly proportioned, mixed and spread on a paved surface. It is written as a guide and should be used as such. End use specifications should be adapted to conform to job and user requirements.

NOTE 1—This practice references test methods outside the jurisdiction of ASTM that may or may not have a precision statement.

1.2 The values stated in SI units are to be regarded as the standard.

1.3 The text of this standard references notes and footnotes which provide explanatory material. These notes and footnotes (excluding those in tables and figures) shall not be considered as requirements of the standard.

1.4 *This standard does not purport to address all of the safety concerns, if any, associated with its use. It is the responsibility of the user of this standard to establish appropriate ~~safety and health~~ safety, health, and environmental practices and determine the applicability of regulatory limitations prior to use.*

1.5 *This international standard was developed in accordance with internationally recognized principles on standardization established in the Decision on Principles for the Development of International Standards, Guides and Recommendations issued by the World Trade Organization Technical Barriers to Trade (TBT) Committee.* [92e-705d677727a5/astm-d6372-23](https://doi.org/10.1520/D6372-23)

### 2. Referenced Documents

#### 2.1 ASTM Standards:<sup>2</sup>

~~C88~~C88/C88M Test Method for Soundness of Aggregates by Use of Sodium Sulfate or Magnesium Sulfate

~~C131~~C131/C131M Test Method for Resistance to Degradation of Small-Size Coarse Aggregate by Abrasion and Impact in the Los Angeles Machine

D8 Terminology Relating to Materials for Roads and Pavements

~~D2397~~D2397/D2397M Specification for Cationic Emulsified Asphalt

D2419 Test Method for Sand Equivalent Value of Soils and Fine Aggregate

D3666 Specification for Minimum Requirements for Agencies Testing and Inspecting Road and Paving Materials

D3910 Practices for Design, Testing, and Construction of Slurry Seal

E145 Specification for Gravity-Convection and Forced-Ventilation Ovens

<sup>1</sup> This practice is under the jurisdiction of ASTM Committee D04 on Road and Paving Materials and is the direct responsibility of Subcommittee D04.24 on Asphalt Surface Treatments.

Current edition approved June 15, 2015; May 1, 2023. Published August 2015; May 2023. Originally approved in 1999. Last previous edition approved in 2010 as ~~D6372—05~~ (2010); ~~D6372 – 15~~. DOI: ~~10.1520/D6372-15~~. 10.1520/D6372-23.

<sup>2</sup> For referenced ASTM standards, visit the ASTM website, www.astm.org, or contact ASTM Customer Service at service@astm.org. For *Annual Book of ASTM Standards* volume information, refer to the standard's Document Summary page on the ASTM website.

## 2.2 ISSA Documents:<sup>3</sup>

- ~~ISSA Technical Bulletin No. 100~~ ~~Technical Bulletin No. 100~~, Test Method for Wet Track Abrasion of Slurry Surfaces  
~~ISSA Technical Bulletin No. 109~~ ~~Technical Bulletin No. 109~~, Test Method for Measurement of Excess Asphalt in Bituminous Mixtures by Use of a Loaded Wheel Tester and Sand Adhesion  
~~ISSA Technical Bulletin No. 139~~ ~~Technical Bulletin No. 139~~, Test Method to Classify Emulsified Asphalt/Aggregate Mixture Systems by Modified Cohesion Tester, Measurement of Set and Cure Characteristics  
~~ISSA A143~~ ~~A143 Revised May 2003~~ Recommended Performance Guidelines For ~~Micro-Surfacing~~ Micro-Surfacing, revised May 2003  
~~ISSA Technical Bulletin No. 144~~ ~~Technical Bulletin No. 144~~, Test Method for Classification of Aggregate Filler—Bitumen Compatibility by Schultze-Breuer and Ruck Procedures  
~~ISSA Technical Bulletin No. 147~~ ~~Technical Bulletin No. 147~~, Test Methods for Measurements of Stability and Resistance to Compaction, Vertical and Lateral Displacement of Multilayered Fine Aggregate Cold Mixes

## 3. Terminology

3.1 *Definitions*—For definitions of terms used in this standard, refer to Terminology **D8**.

3.2 *Definitions of Terms Specific to This Standard:*

3.2.1 *flashing, n*—as related to the compaction of microsurfacing test specimens, the excess material overhanging the two parallel bases of the cylindrical specimen.

3.2.2 ~~*polymer-modified polymer-modified emulsified asphalt micro-surfacing*~~ *microsurfacing mixtures, mixtures—n*—as related to this practice, mixtures of fine aggregate with mineral filler, mixing water, and field control additive, uniformly mixed with ~~polymer modified~~ polymer-modified emulsified asphalt.

## 4. Summary of Practice

4.1 This practice outlines the basic properties for materials, mix design procedures, and application techniques for the design and application of microsurfacing. The mix developed through this practice should be capable of being spread in variable thick cross sections, which after curing and initial traffic consolidation, resist compaction through the entire design tolerance range of bitumen content and variable thickness to be encountered. The end product should maintain a high friction surface and variable thick sections throughout its surface life. The mix should be a quick traffic system and should be able to accept rolling traffic on a 12.7 mm thick surface within 1 h after placement in  $24^{\circ}\text{C}$   $24^{\circ}\text{C}$  temperature and 50 % or less humidity.

<https://standards.iteh.ai/catalog/standards/sist/ceaf10e1f-6a08-46b4-992e-705d677127a5/astm-d6372-23>

## 5. Significance and Use

5.1 This microsurfacing practice is written as a guide and should not be construed as a specification. End use specifications should be adapted to conform to job and user requirements.

NOTE 2—The quality of the results produced by this standard are dependent on the competence of the personnel performing the procedure and the capability, calibration, and maintenance of the equipment used. Agencies that meet the criteria of Specification **D3666** are generally considered capable of competent and objective testing, sampling, inspection, etc. Users of this standard are cautioned that compliance with Specification **D3666** alone does not completely ensure reliable results. Reliable results depend on many factors; following the suggestions of Specification **D3666** or some similar acceptable guideline provides a means of evaluating and controlling some of those factors.

## 6. Design

6.1 *Aggregates*—The aggregate shall be a manufactured crushed stone such as granite, slag, limestone, chat, or other high quality aggregate or combination thereof. The aggregate shall be totally crushed with 100 % of the parent aggregate being larger than the largest stone in the gradation to be used. Recommended grading requirements are shown in **Table 1**. When tested by Test Method **D2419**, the combined aggregate prior to the addition of any chemically active mineral filler shall have a sand equivalent of not less than 65. When tested by Test Method ~~**C88/C88M**~~ the aggregate shall have a weighed average loss not greater than 15 % using sodium sulfate or 25 % using magnesium sulfate. Testing by Test Method ~~**C131/C131M**~~ shall show an abrasion resistance of 30 % maximum.

<sup>3</sup> Available from International Slurry Surfacing Association, 3 Church Circle, PMB 250, Annapolis, MD 21401.

**TABLE 1 Grading Requirements**

Sieve Size	Type II Percent Passing	Type III Percent Passing	Stockpile Tolerance
9.5 mm	100	100	
4.75 mm	90 to 100	70 to 90	± 5 %
2.36 mm	65 to 90	45 to 70	± 5 %
1.18 mm	45 to 70	28 to 50	± 5 %
600 µm	30 to 50	19 to 34	± 5 %
330 µm	18 to 30	12 to 25	± 4 %
150 µm	10 to 21	7 to 18	± 3 %
75 µm	5 to 15	5 to 15	± 2 %

6.2 *Mineral Filler*—Mineral filler shall be any recognized brand of nonairentrained portland cement or hydrated lime. The mineral filler shall be free of lumps and accepted upon visual inspection. The type and amount of mineral filler needed shall be determined by a laboratory mix design and will be considered as part of the aggregate gradation.

6.3 *Emulsified Asphalt*—The emulsified asphalt shall be a quick-set polymer-modified quick-set polymer-modified asphalt emulsion conforming to the requirements of Specification ~~D2397~~D2397/D2397M for ~~CSS-1h~~CQS-1h. The polymer material shall be milled or blended into the asphalt or emulsifier solution prior to the emulsification process. The cement mixing test shall be waived for this emulsion. The five day settlement test may be waived. Refer to ISSA Document A143.

## 7. Composition of Microsurfacing Mixtures

7.1 A job mixture shall be selected that conforms to the specifications for a quick traffic system, meaning that it will be able to accept traffic after a short period of time and is capable of being spread in variable cross sections, wedges, ruts, scratch courses, and surfaces and that after curing and initial traffic consolidation resists compaction throughout the entire design tolerance range of bitumen content and variable thickness to be encountered. The mixture should maintain a high friction surface, and variable thick sections throughout the service life of the mixture. The mixture shall be able to accept rolling traffic on a 12.7 mm thick surface within 1 h after placement at ~~24°C~~24 °C temperature and 50 % or less humidity. The mixture shall conform to one of the gradation types listed in **Table 1**. Type II is suitable for urban and residential streets and airport runways. It shall be applied at the minimum rate of 5.4 to ~~8.1~~8.1 kg kg/m<sup>2</sup>. Type III is suitable for primary and interstate routes and to fill wheel ruts. It shall be applied at the rate of 8.1 to ~~16.2~~16.2 kg kg/m<sup>2</sup>; for primary and interstate routes. The application for wheel ruts shall be as prescribed in **Appendix X1**.

## 8. Test Procedures For Mix Design of ~~Polymer-Modified~~Polymer-Modified Emulsified Asphalt Microsurfacing Systems

### 8.1 Cohesion Test:

8.1.1 This test procedure is used to determine various set times of the microsurfacing mixture. It measures torque of a microsurfacing mixture as it coalesces and develops cohesive strength. The amount of torque developed plotted over time shows how the mixture is developing resistance to movement. Specific torque and time values are defined as “set time” and “early rolling traffic time” (see **Fig. 1**).

8.1.2 Set time is defined as the lapsed time after casting a specimen of the microsurfacing mixture after which it cannot be remixed homogeneously (there is no free emulsion to lubricate the system) and no lateral displacement is possible when it is compacted. It is further defined as the time when there are no signs of free emulsion when pressed with an absorptive paper towel and there is no free emulsion diluted and washed away when rinsed with water.

8.1.3 Early rolling traffic time is defined as the time at which the microsurfacing mixture will accept rolling traffic without picking or deformation.

8.1.4 Set times for the microsurfacing mixture shall be determined as outlined in ~~6.36.2~~ of Practice **D3910**.

NOTE 3—~~Referenced~~Reference ISSA Technical Bulletin No. 139.

### 8.2 Wet Track Abrasion Test:

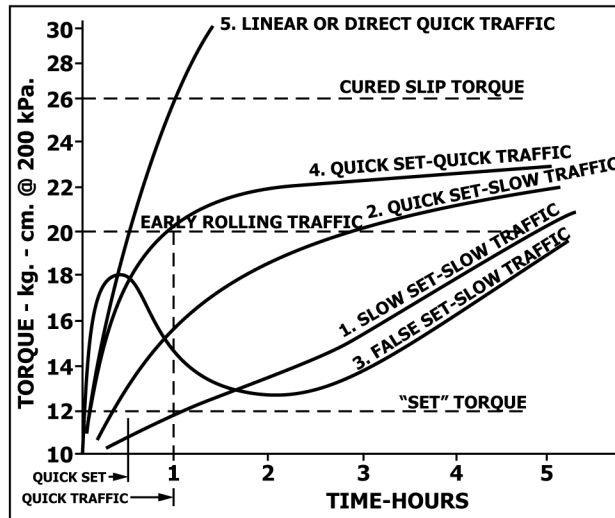

FIG. 1 Classification of Mix Systems by Modified Cohesion Test Curves

8.2.1 This test procedure is used to determine the minimum asphalt content and resistance to abrasion.

8.2.2 It establishes the minimum permissible emulsion content of a given microsurfacing system and the ~~long-term~~ long-term moisture susceptibility of the system.

8.2.3 The test shall be run in accordance with Practice D3910, Section 6.4.

NOTE 4—~~Referenced~~Reference ISSA Technical Bulletin No. 100.

8.3 *Loaded Wheel Test*—This test procedure measures the amount of compaction and displacement characteristics of multi-layered microsurfacing mixtures under simulated rolling traffic compaction (see Fig. 2).

8.3.1 *Summary of Test Procedure:*

8.3.1.1 A 500 g dry aggregate weight mixture is prepared using 0/#4 or other gradation aggregate and the desired quantities of fillers, water, additives, and asphalt emulsion. After 30 s of vigorous mixing, the mixture is cast into a 12.7 by 50.8 mm by 38.1 cm mold centered over a 0.60 mm mounting plate and immediately struck-off uniformly with a wooden dowel or U-shaped wooden screed using a sawing action. The inside surfaces of the mold may be coated with a thin coating of petroleum jelly or a mixture of glycerin and talc as a mold release to prevent sticking.

8.3.1.2 As soon as the mixture is sufficiently set to prevent free flow, the mold is carefully removed without disturbing the specimen. The specimen is air cured for 24 h, then dried to a constant weight in a forced draft oven at 60°C for 18 to 20 h. After cooling, the specimen is measured centrally for width and net thickness. The net weight of the specimen is obtained and recorded. The specimen is then mounted in the loaded wheel track machine and subjected to 1000, 56.7 kg cycles of compaction. The specimen is then removed and immediately remeasured laterally in the wheel path and the results recorded. The lateral displacement is expressed as the percent increase of the original width. The specific gravity should be expressed as the increase by percent after compaction of the specimen.

NOTE 5—The weight of 56.7 kg is total weight applied to the test specimen. The weight includes the mass of the wheel and any additional mass applied to the carriage holder.

8.3.2 *Apparatus:*

8.3.2.1 *Balance*, capable of weighing 2000 g or more to within  $\pm 1.0 \pm 1.0$  g.

8.3.2.2 *Loaded Wheel Tester*, (as described in ISSA TB109) consisting of a 7.62 cm diameter soft rubber wheel loaded with 56.7 kg which reciprocates through a 30.48 cm horizontal path at the rate of 44 cycles per minute.

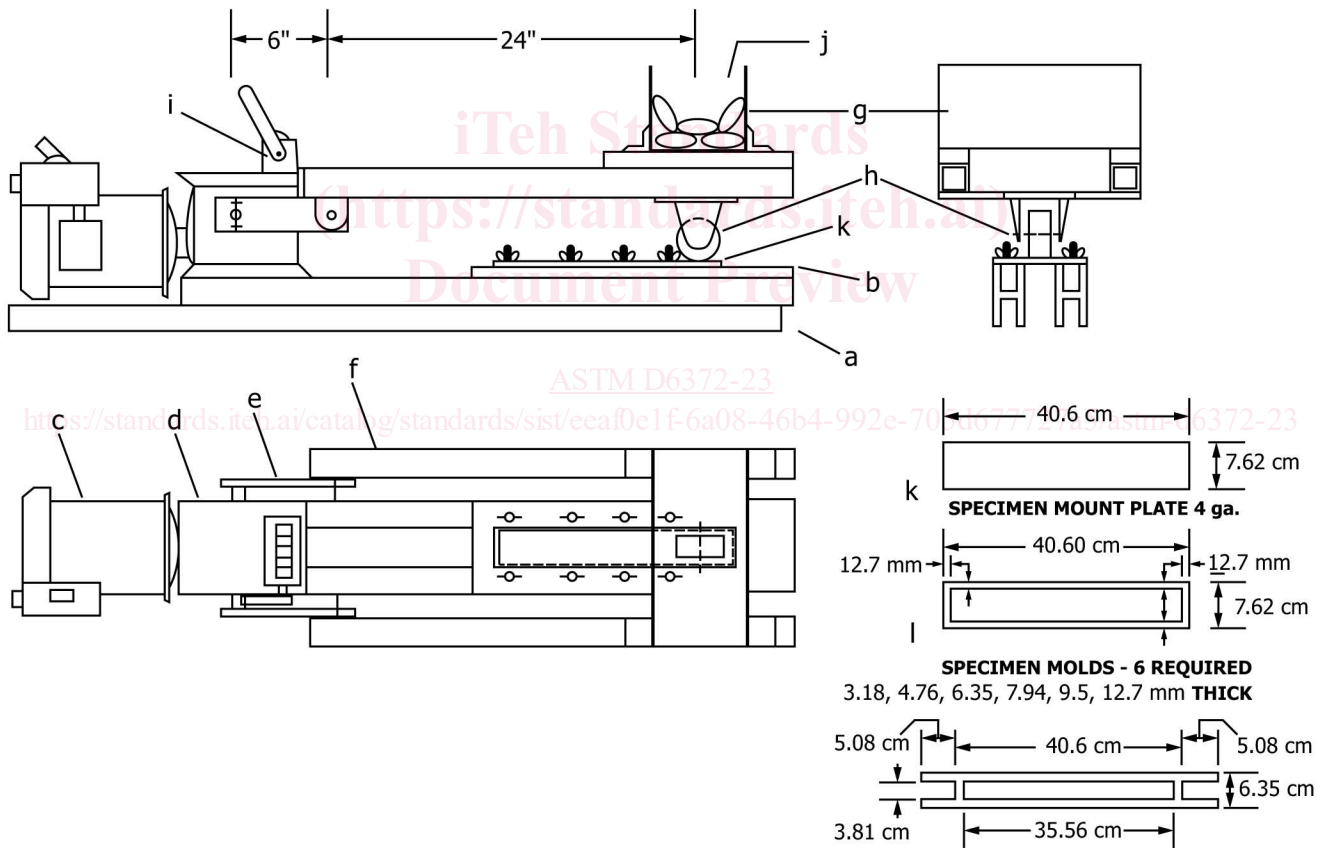
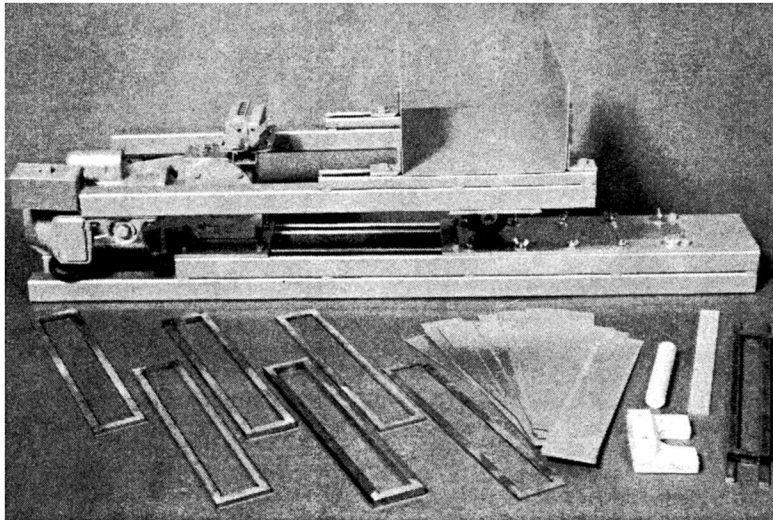

FIG. 2 Loaded Wheel Tester

- 8.3.2.3 *Suitable Heavy Gage Round Bottom Bowl*, suitable to prepare 500 gram-500 g mixes.
- 8.3.2.4 *Long-Handled-Long-Handled Steel Spoon*, or suitable spatula for mixing of aggregate emulsion mixtures.
- 8.3.2.5 *Specimen Mounting Plate*, (0.60 mm galvanized steel 7.62 by 40.6 cm, deburred).



8.3.2.6 *Specimen Mold*, 12.7 mm thick by 76.2 mm ~~×~~by 40.6 cm outside and 50.8 mm by 38.1 cm inside dimensions.

8.3.2.7 *Calipers*, capable of measuring specimen width to within 0.01 mm.

8.3.2.8 *Oven*, forced draft constant temperature thermostatically controlled at  $60 \pm 3^\circ\text{C}$ :3 °C. See specification E145 Type IIB.

8.3.3 *Preparation of Test Specimen:*

8.3.3.1 A ~~500-gram~~500 g dry weight aggregate mixture is prepared using the 4.75 mm and smaller fractions, the desired quantities of fillers, water additives, and asphalt emulsion.

8.3.3.2 After 30 s of vigorous mixing, cast the mixture into the mold, centered over the 0.60 mm mounting plate and immediately struck-off uniformly with a wooden dowel or ~~U-shaped~~U-shaped wooden screed using a sawing action. The casting operation should be completed within 15 s so that no more than ~~45 s~~45 s has elapsed from starting the mix to finishing the specimen.

8.3.3.3 As soon as the mixture is sufficiently set to prevent free flow, carefully remove the mold without disturbing the specimen. Then air-cure the specimen for 24 h and then dry to a constant weight in a forced draft oven at ~~60°C~~60 °C for 18 to ~~20 h~~20 h.

8.3.3.4 After cooling for 2 h to room temperature, measure the specimen with the calipers for net lateral thickness.

8.3.3.5 Then mount the specimen in the loaded wheel tester machine and subject it to 1000 cycles of compaction at a temperature of ~~22± 2°C~~22 ± 2 °C.

8.3.3.6 Then remove the specimen from the loaded wheel tester machine and immediately remeasure laterally.

NOTE 6—Reference ISSA Technical Bulletin No. 147.

~~8.3.3.7 Reference Document ISSA Technical Bulletin No. 147.~~

8.4 *Classification Test*—This test procedure covers the determination of the relative compatibility between aggregate filler of specific gradation and emulsified asphalt residue. [ASTM D6372-23](https://standards.iteh.ai/catalog/standards/sist/eeaf0e1f-6a08-46b4-992e-705d677727a5/astm-d6372-23)

8.4.1 *Summary of Test Procedure*—The test procedure provides a rating system or grading values for abrasion loss, adhesion, and high temperature cohesion characteristics of a specified aggregate-bitumen combination for comparison with test values of referenced combinations. <https://standards.iteh.ai/catalog/standards/sist/eeaf0e1f-6a08-46b4-992e-705d677727a5/astm-d6372-23>

8.4.2 *Apparatus:*

8.4.2.1 *Balance*, capable of weighing 1000 g sensitive to  $0.01 \pm 0.005$  g:readable to 0.01 g.

8.4.2.2 *Oven*, forced draft constant temperature thermostatically controlled at  $60 \pm 3^\circ\text{C}$ :3 °C. See Specification E145 Type IIB.

8.4.2.3 *Suitable Heavy Gage Round Bottom Bowl*, to contain 200 g of mixture.

8.4.2.4 *Suitable Mixing Spatula*, or ~~long-handled~~long-handled metal spoon.

8.4.2.5 *Metal Pill Mold*, consisting of a base, a case 30 mm inside diameter by 70 mm height, and a 29 mm diameter ram.

8.4.2.6 *Constant Force Press*, capable of exerting a constant force of 1000 kg.

8.4.2.7 *Shuttle Cylinders*, consisting of acrylic tubes 60 mm inside diameter by 400 mm inside length containing  $1100 \pm 25$  mm:25 mm. Volume enclosed with ~~water-tight~~watertight metal caps at each end, one of which is readily removable.

8.4.2.8 *Abrasion Machine*, capable of holding at least two pairs of shuttle cylinders and rotating them end for end about a central axis at 20 rpm (see Fig. 3).

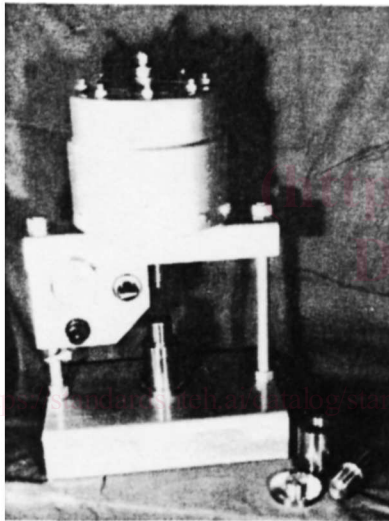
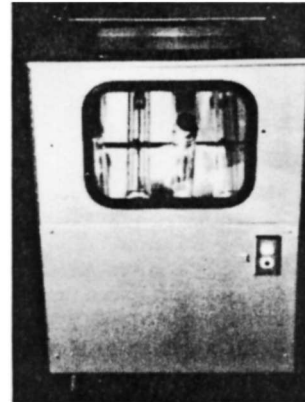
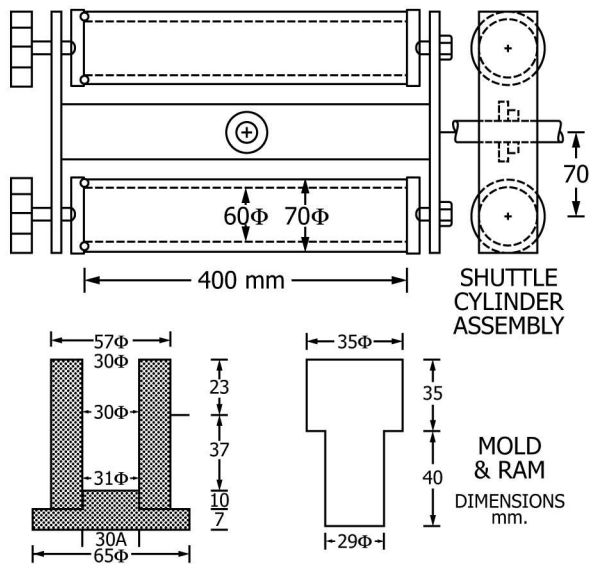

Constant Force Pill Press and Molds

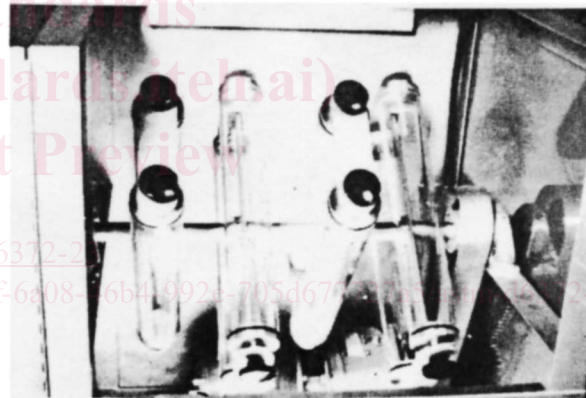

Above: Safety Cabinet Closed  
Below: Shuttle Cylinder Assembly

FIG. 3 Schulze-Breuer Abrasion Machine

8.4.2.9 *Open Top 6 mm Galvanized Hardware Cloth Baskets*, 50 mm diameter by 50 mm high with suitable means for suspension in boiling water.

8.4.2.10 *Hot Plate*, capable of heating 500 ml of water to boiling.

8.4.2.11 *800 ml Metal or Glass Beaker*, capable of holding boiling water. 800 mL metal or glass beaker.

8.4.2.12 *Water Bath*, capable of maintaining a bath temperature of  $25 \pm 5$  °C.

8.4.3 *Preparation of Test Specimen:*

8.4.3.1 The aggregate to be used shall be dry sieved and regraded as prescribed (see Table 2).