



Designation: E822 – 92 (Reapproved 2023)

Standard Practice for Determining Resistance of Solar Collector Covers to Hail by Impact with Propelled Ice Balls¹

This standard is issued under the fixed designation E822; the number immediately following the designation indicates the year of original adoption or, in the case of revision, the year of last revision. A number in parentheses indicates the year of last reapproval. A superscript epsilon (ϵ) indicates an editorial change since the last revision or reapproval.

This standard has been approved for use by agencies of the U.S. Department of Defense.

1. Scope

1.1 This practice covers a procedure for determining the ability of cover plates for flat-plate solar collectors to withstand impact forces of falling hail. Propelled ice balls are used to simulate falling hailstones. This practice is not intended to apply to photovoltaic cells or arrays.

1.2 This practice defines two types of test specimens, describes methods for mounting specimens, specifies impact locations on each test specimen, provides an equation for determining the velocity of any size ice ball, provides a method for impacting the test specimens with ice balls, and specifies parameters that must be recorded and reported.

1.3 This practice does not establish pass or fail levels. The determination of acceptable or unacceptable levels of ice-ball impact resistance is beyond the scope of this practice.

1.4 The size of ice ball to be used in conducting this test is not specified in this practice. This practice can be used with various sizes of ice balls.

1.5 The categories of solar collector cover plate materials to which this practice may be applied cover the range of:

- 1.5.1 Brittle sheet, such as glass,
- 1.5.2 Semirigid sheet, such as plastic, and
- 1.5.3 Flexible membrane, such as plastic film.

1.6 Solar collector cover materials should be tested as:

- 1.6.1 Part of an assembled collector (Type 1 specimen), or
- 1.6.2 Mounted on a separate test frame cover plate holder (Type 2 specimen).

1.7 The values stated in SI units are to be regarded as the standard. The values given in parentheses are for information only.

1.8 *This standard does not purport to address all of the safety concerns, if any, associated with its use. It is the*

responsibility of the user of this standard to establish appropriate safety, health, and environmental practices and determine the applicability of regulatory limitations prior to use.

1.9 *This international standard was developed in accordance with internationally recognized principles on standardization established in the Decision on Principles for the Development of International Standards, Guides and Recommendations issued by the World Trade Organization Technical Barriers to Trade (TBT) Committee.*

2. Significance and Use

2.1 In many geographic areas there is concern about the effect of falling hail upon solar collector covers. This practice may be used to determine the ability of flat-plate solar collector covers to withstand the impact forces of hailstones. In this practice, the ability of a solar collector cover plate to withstand hail impact is related to its tested ability to withstand impact from ice balls. The effects of the impact on the material are highly variable and dependent upon the material.

2.2 This practice describes a standard procedure for mounting the test specimen, conducting the impact test, and reporting the effects.

2.2.1 The procedures for mounting cover plate materials and collectors are provided to ensure that they are tested in a configuration that relates to their use in a solar collector.

2.2.2 The corner locations of the four impacts are chosen to represent vulnerable sites on the cover plate. Impacts near corner supports are more critical than impacts elsewhere. Only a single impact is specified at each of the impact locations. For test control purposes, multiple impacts in a single location are not permitted because a subcritical impact may still cause damage that would alter the response to subsequent impacts.

2.2.3 Resultant velocity is used to simulate the velocity that may be reached by hail accompanied by wind. The resultant velocity used in this practice is determined by vector addition of a 20 m/s (45 mph) horizontal velocity to the vertical terminal velocity.

2.2.4 Ice balls are used in this practice to simulate hailstones because natural hailstones are not readily available to use, and ice balls closely approximate hailstones. However, no direct relationship has been established between the effect of impact

¹ This practice is under the jurisdiction of ASTM Committee E44 on Solar, Geothermal and Other Alternative Energy Sources and is the direct responsibility of Subcommittee E44.20 on Optical Materials for Solar Applications.

Current edition approved May 1, 2023. Published May 2023. Originally approved in 1981. Last previous edition approved in 2015 as E822 – 92 (2015). DOI: 10.1520/E0822-92R23.

of ice balls and hailstones. Hailstones are highly variable in properties such as shape, density, and frangibility.² These properties affect factors such as the kinetic energy delivered to the cover plate, the period during which energy is delivered, and the area over which the energy is distributed. Ice balls, with a density, frangibility, and terminal velocity near the range of hailstones, are the nearest hailstone approximation known at this time. Perhaps the major difference between ice balls and hailstones is that hailstones are much more variable than ice balls. However, ice balls can be uniformly and repeatedly manufactured to ensure a projectile with known properties.

2.2.5 A wide range of observable effects may be produced by impacting the various types of cover plate materials. The effects may vary from no effect to total destruction. Some changes in the cover material may be visible when there is no apparent functional impairment of the cover plate material. All effects of each impact must be described in the report so that an estimate of their significance can be made.

2.3 Data generated using this practice may be used: (1) to evaluate impact resistance of a single material or collector, (2) to compare the impact resistance of several materials or collectors, (3) to provide a common basis for selection of cover materials or collectors for use in various geographic areas, or (4) to evaluate changes in impact resistance due to environmental factors such as weather.

2.4 This practice does not state the size(s) of ice ball(s) to be used in making the impact. Either the person requesting the test or the person performing the test must determine ice ball size to be used in the testing. Choice of ice ball size may relate to the intent of the testing.

2.4.1 If the testing is being performed to evaluate impact resistance of a single material or collector, or several materials or collectors, it may be desirable to repeat the test using several sizes of ice balls. In this manner the different effects of various sizes of ice balls may be determined.

2.4.2 The size and frequency of hail varies significantly among various geographic areas. If testing is being performed to evaluate materials or collectors intended for use in a specific geographic area, the ice ball size should correspond to the level of hail impact resistance required for that area. Information on hail size and frequency may be available from local historical weather records or may be determined from the publications listed in Appendix X1.

2.5 The hail impact resistance of materials may change as the materials are exposed to various environmental factors. This practice may be used to generate data to evaluate degradation by comparison of hail impact resistance data measured before and after exposure to such aging.

3. Apparatus

3.1 *Launcher*—A mechanism capable of propelling a selected ice ball at the corresponding resultant velocity. The aiming accuracy of the launcher must be sufficient to propel the ice ball to strike the cover plate within 25 mm (± 1 in.) of the specified impact points. See Fig. 1.

² Gokhale, N. R., *Hailstorms and Hailstone Growth*, State University of New York Press, Albany, NY, 1975.

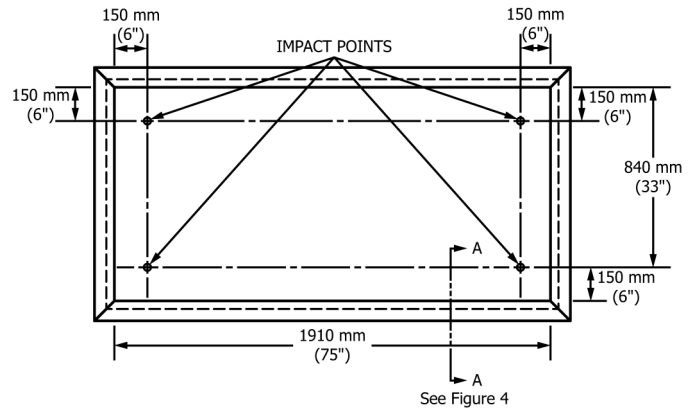

FIG. 1 Frame Dimensions and Location of Test Impact Points

NOTE 1—A launcher that has proven suitable uses a compressed air supply, an accumulator tank, a large-diameter quick-opening valve, and interchangeable barrels to accommodate the sizes of ice balls to be used. Barrels should be made from materials with low thermal conductivity to reduce melting of the ice ball. Barrels should be sized such that the ice ball remains intact during loading and launching.

3.2 *Velocity Meter*, for measuring the ice ball velocity with an accuracy of ± 2.0 %.

3.3 *Test Base*—A structurally rigid support for mounting a complete solar collector panel (Type 1 specimen), or for mounting a solar collector cover plate material (Type 2 specimen) set in the cover holder.

3.4 *Cover Holder*—A rigid edging frame (see Figs. 1 and 2) designed to hold an approximately 860 by 1930-mm (34 by 76-in.) cover plate.

NOTE 2—Hardwood, such as oak, birch, maple, or hickory, is mandatory if wood is used for the cover holder.

NOTE 3—Corner straps, as shown in Figs. 3 and 4, have been found useful to ensure the cover holder is rigid.

3.5 *Molds*, for casting spherical crack-free ice balls of appropriate diameter.

NOTE 4—Molds made from room temperature vulcanizing rubber and expanded polystyrene have been found suitable.

3.6 *Freezer*—A device controlled at -12 ± 5 °C (10 ± 9 °F) for making and storing ice balls.

4. Test Specimen

4.1 *Type 1*—The test specimen shall consist of a complete glazing assembly or a complete solar collector panel with necessary mounting brackets or fixtures.

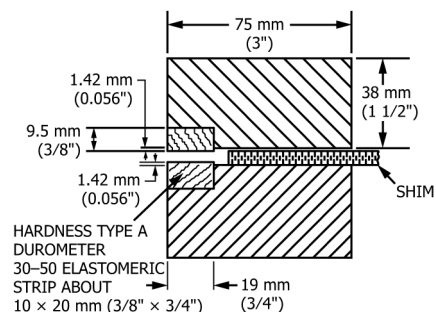
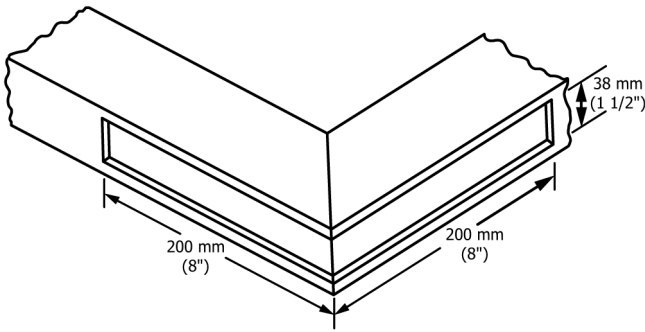

FIG. 2 Cover Holder, Empty (Section A-A of Fig. 1)



NOTE 1—Slot corner as indicated to fit steel corner straps. Straps should be flush with surface.

FIG. 3 Slots for Corner Straps of Cover Holder

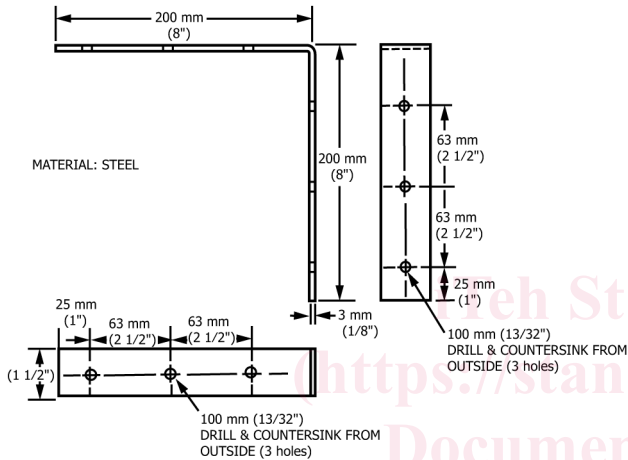

FIG. 4 Detail of Corner Straps for Cover Holder

4.2 *Type 2*—The test specimen shall consist of a section of solar collector cover plate material mounted in the cover holder.

5. Mounting

5.1 *Type 1*—Position and support the test specimen on a suitable test base using necessary mounting brackets or fixtures, or both. Do not obstruct the specified impact points by the mounting fixtures.

5.2 *Type 2*—Secure the test specimen in the cover holder, as shown in Fig. 2 and Fig. 5, and mount the cover holder (with the cover) on a suitable test base. Provide sufficient clearance on the side opposite the impact surface to permit unobstructed deflection of the cover material.

5.2.1 Lay brittle sheet cover materials, approximately 860 by 1930 mm (34 by 76 in.), on the elastomeric gasket (Type A durometer rating 30 to 50) of one member of the cover holder. Put the shim in place. Lay the other member of the cover holder on top. Tighten the bolts or C-clamp screws until the elastomeric gaskets are compressed and the shim is firmly held, as shown in Fig. 5 (Note 5). Mount the specimen firmly on the test base for testing.

NOTE 5—If the cover plate material will be damaged by the procedure specified herein, the bolts or C-clamp screws should be tightened sufficiently to hold the specimen in the frame, but not tightened to the extent that permanent deformations are made in the cover plate material.

5.2.2 Clamp semirigid sheet (plastic) cover materials in the cover holder in the same manner as brittle sheet cover materials.

5.2.3 Flexible Membrane:

5.2.3.1 Mount the material in accordance with the manufacturer's recommendations on a suitable rigid subframe approximately 860 by 1930 mm (34 by 76 in.). Mount the subframe in the cover holder in the same manner as described for brittle sheet in 5.2.1.

5.2.3.2 Alternatively, set flexible membrane cover materials in the holder and place under biaxial tension (normal to length and width).

NOTE 6—This may be accomplished by cutting the films oversize,

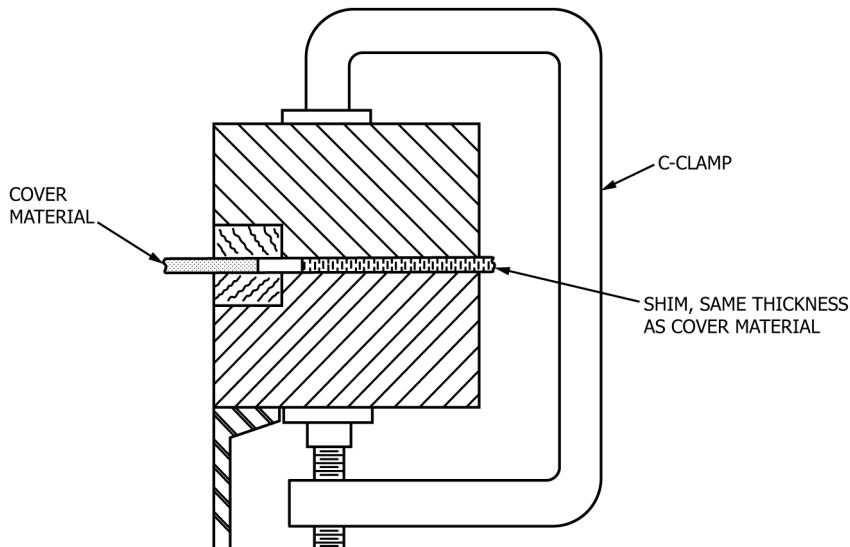

NOTE 1—Bolts may be used in place of C-clamps if the bolt does not penetrate the test specimen (that is, for rigid sheet).

FIG. 5 Cover Holder, Loaded