



Designation: A350/A350M – 23

# Standard Specification for Carbon and Low-Alloy Steel Forgings, Requiring Notch Toughness Testing for Piping Components<sup>1</sup>

This standard is issued under the fixed designation A350/A350M; the number immediately following the designation indicates the year of original adoption or, in the case of revision, the year of last revision. A number in parentheses indicates the year of last reapproval. A superscript epsilon ( $\epsilon$ ) indicates an editorial change since the last revision or reapproval.

*This standard has been approved for use by agencies of the U.S. Department of Defense.*

## 1. Scope\*

1.1 This specification<sup>2</sup> covers several grades of carbon and low-alloy steel forged or ring-rolled flanges, forged fittings and valves intended primarily for low-temperature service and requiring notch toughness testing. They are made to specified dimensions, or to dimensional standards, such as the ASME and API Specifications referenced in Section 2. Although this specification covers some piping components machined from rolled bar and seamless tubular materials (see 5.3.3), it does not cover raw material produced in these product forms.

1.2 No limitation on size is intended beyond the ability of the manufacturer to obtain the specified requirements. However, Class 3 of Grade LF787 is only available in the quenched-and-precipitation heat treated condition.

1.3 Supplementary requirements are provided for use when additional testing or inspection is desired. These shall apply only when specified by the purchaser in the order.

1.4 This specification is expressed in both inch-pound units and in SI units. However, unless the order specifies the applicable “M” specification designation (SI units), the material shall be furnished to inch-pound units.

1.5 The values stated in either SI units or inch-pound units are to be regarded separately as standard. Within the text, the SI units are shown in brackets. The values stated in each system may not be exact equivalents; therefore, each system shall be used independently of the other. Combining values from the two systems may result in non-conformance with the standard.

1.6 *This international standard was developed in accordance with internationally recognized principles on standardization established in the Decision on Principles for the*

*Development of International Standards, Guides and Recommendations issued by the World Trade Organization Technical Barriers to Trade (TBT) Committee.*

## 2. Referenced Documents

### 2.1 ASTM Standards:<sup>3</sup>

A788/A788M Specification for Steel Forgings, General Requirements

A961/A961M Specification for Common Requirements for Steel Flanges, Forged Fittings, Valves, and Parts for Piping Applications

### 2.2 ASME Standards:

B 16.5 Steel Pipe Flanges and Flanged Fittings<sup>4</sup>

B 16.9 Factory-Made Wrought Steel Butt-Welding Fittings<sup>4</sup>

B 16.10 Face-to-Face and End-to-End Dimensions of Ferrous Valves<sup>4</sup>

B 16.11 Forged Steel Fittings, Socket-Welding and Threaded<sup>4</sup>

B 16.30 Unfired Pressure Vessel Flange Dimensions<sup>4</sup>

B 16.34 Valves-Flanged, Threaded, and Welding End<sup>4</sup>

B 16.47 Large Diameter Steel Flanges<sup>4</sup>

2.3 ASME Boiler and Pressure Vessel Code: Section IX<sup>2</sup>

### 2.4 AWS Standards:

A 5.1 Mild Steel Covered Arc-Welding Electrodes<sup>5</sup>

A 5.5 Low-Alloy Steel Covered Arc-Welding Electrodes<sup>5</sup>

### 2.5 API Standards:<sup>6</sup>

600 Steel Gate Valves with Flanged or Butt-Welding Ends

602 Compact Design Carbon Steel Gate Valves for Refinery Use

605 Large Diameter Carbon Steel Flanges

<sup>3</sup> For referenced ASTM standards, visit the ASTM website, [www.astm.org](http://www.astm.org), or contact ASTM Customer Service at [service@astm.org](mailto:service@astm.org). For *Annual Book of ASTM Standards* volume information, refer to the standard's Document Summary page on the ASTM website.

<sup>4</sup> Available from American Society of Mechanical Engineers (ASME), ASME International Headquarters, Two Park Ave., New York, NY 10016-5990, <http://www.asme.org>.

<sup>5</sup> Available from American Welding Society (AWS), 550 NW LeJeune Rd., Miami, FL 33126, <http://www.aws.org>.

<sup>6</sup> Available from American Petroleum Institute (API), 1220 L. St., NW, Washington, DC 20005-4070, <http://api-ec.api.org>.

<sup>1</sup> This specification is under the jurisdiction of ASTM Committee A01 on Steel, Stainless Steel and Related Alloys and is the direct responsibility of Subcommittee A01.22 on Steel Forgings and Wrought Fittings for Piping Applications and Bolting Materials for Piping and Special Purpose Applications.

Current edition approved May 1, 2023. Published May 2023. Originally approved in 1952. Last previous edition approved in 2018 as A350/A350M – 18. DOI: 10.1520/A0350\_A0350M-23.

<sup>2</sup> For ASME Boiler and Pressure Vessel Code applications see related Specification SA-350 in Section II of that Code.

\*A Summary of Changes section appears at the end of this standard

### 3. Ordering Information

3.1 It is the purchaser's responsibility to specify in the purchase order information necessary to purchase the needed material. In addition to the ordering information guidelines in Specification **A961/A961M**, orders should include the following information:

- 3.1.1 The number of test reports required (see Section 14).
- 3.1.2 Additional requirements (see **Table 1** footnotes).
- 3.1.3 Options in the specification. See **5.4.2.1**.

### 4. General Requirements

4.1 Product furnished to this specification shall conform to the requirements of Specification **A961/A961M**, including any supplementary requirements that are indicated in the purchase order. Failure to comply with the general requirements of Specification **A961/A961M** constitutes nonconformance with this specification. In case of conflict between the requirements of this specification and Specification **A961/A961M**, this specification shall prevail.

### 5. Manufacture

5.1 *Melting Process*—The steel shall be produced by any of the following primary processes: open-hearth, basic oxygen, electric-furnace, or vacuum-induction melting (VIM). The primary melting may incorporate separate degassing or refining, and may be followed by secondary melting using electroslag remelting (ESR), or vacuum-arc remelting (VAR).

5.1.1 The steel shall be fully killed, fine-grain practice.

5.1.2 The molten steel may be vacuum treated prior to or during pouring of the ingot.

5.2 *Discard*—A sufficient discard shall be made to secure freedom from injurious piping and undue segregation.

5.3 *Forging Process*:

5.3.1 Material for forgings shall consist of ingots, or forged, rolled, or strandcast blooms, billets, slabs, or bars.

5.3.2 The finished product shall be a forging as defined in the Terminology section of Specification **A788/A788M**.

5.3.3 Hollow parts may be machined from rolled bar or seamless tubular materials provided the longitudinal axis of the part is parallel to the longitudinal axis of the bar. Other parts, up to and including NPS4, may be machined from hot-rolled or forged bar provided the longitudinal axis of the part is parallel to the longitudinal axis of the bar. Flanges, elbows, return bends, tees, and header tees shall not be machined directly from bar stock.

5.4 *Heat Treatment*:

5.4.1 After hot working and before reheating for heat treatment, the forging shall be allowed to cool substantially below the transformation range.

5.4.2 Forgings of grades other than Grade LF787 shall be furnished in the normalized, or normalized and tempered, or quenched and tempered condition. At the option of the manufacturer, forgings furnished in the quenched and tempered condition may be normalized prior to the austenitize/quench operation.

5.4.2.1 Quenching shall consist of either:

(1) fully austenitizing the forgings followed by quenching in a suitable liquid medium, or

(2) using a multiple stage procedure whereby the forging is first fully austenitized and rapidly cooled, then reheated to partially re-austenitize, followed by quenching in a suitable liquid medium.

(3) Unless otherwise specified by the purchaser, the choice of (1) or (2) shall be at the option of the manufacturer.

5.4.2.2 All quenched forgings shall be tempered to **5.4.2.3**

5.4.2.3 Forgings, when tempered, shall be tempered at 1100 °F [590 °C], minimum, holding at temperature a minimum of 30 min/in. [30 min/25 mm] of maximum thickness, but in no case less than 30 min.

5.4.3 Grade LF787 forgings shall be furnished in either the normalized-and-precipitation heat treated condition or in the quenched-and-precipitation heat treated condition. The heat treatment procedures shall be as follows:

5.4.3.1 *Normalized-and-Precipitation Heat Treated*—Austenitize in the range from 1600 to 1725 °F [870 to 940 °C]

**TABLE 1 Chemical Requirements**

Element	Composition, wt. %						
	Grade LF1	Grade LF2	Grade LF3	Grade LF5	Grade LF6	Grade LF9	Grade LF787
Carbon, max	0.30	0.30	0.20	0.30	0.22	0.20	0.07
Manganese	0.60–1.35	0.60–1.35	0.90 max	0.60–1.35	1.15–1.50	0.40–1.06	0.40–0.70
Phosphorus, max	0.035	0.035	0.035	0.035	0.025	0.035	0.025
Sulfur, max	0.040	0.040	0.040	0.040	0.025	0.040	0.025
Silicon <sup>A</sup>	0.15–0.30	0.15–0.30	0.20–0.35	0.20–0.35	0.15–0.30	...	0.40 max
Nickel	0.40 max <sup>B</sup>	0.40 max <sup>B</sup>	3.3–3.7	1.0–2.0	0.40 max <sup>B</sup>	1.60–2.24	0.70–1.00
Chromium	0.30 max <sup>B,C</sup>	0.30 max <sup>B,C</sup>	0.30 max <sup>C</sup>	0.30 max <sup>C</sup>	0.30 max <sup>B,C</sup>	0.30 max <sup>C</sup>	0.60–0.90
Molybdenum	0.12 max <sup>B,C</sup>	0.12 max <sup>B,C</sup>	0.12 max <sup>C</sup>	0.12 max <sup>C</sup>	0.12 max <sup>B,C</sup>	0.12 max <sup>C</sup>	0.15–0.25
Copper	0.40 max <sup>B</sup>	0.40 max <sup>B</sup>	0.40 max	0.40 max	0.40 max <sup>B</sup>	0.75–1.25	1.00–1.30
Niobium <sup>E</sup>	0.02 max <sup>D</sup>	0.02 max <sup>D</sup>	0.02 max	0.02 max	0.02 max	0.02 max	0.02 min
Vanadium	0.08 max	0.08 max	0.03 max	0.03 max	0.04–0.11	0.03 max	0.03 max
Nitrogen	...	...	...	...	0.01–0.030	...	...

<sup>A</sup> When vacuum carbon-deoxidation is required by Supplementary Requirement S4, the silicon content shall be 0.12 % maximum.

<sup>B</sup> The sum of copper, nickel, chromium, vanadium and molybdenum shall not exceed 1.00 % on heat analysis.

<sup>C</sup> The sum of chromium and molybdenum shall not exceed 0.32 % on heat analysis.

<sup>D</sup> By agreement, the limit for niobium (columbium) may be increased up to 0.05 % on heat analysis and 0.06 % on product analysis.

<sup>E</sup> Niobium and columbium are interchangeable names for the same element and both names are acceptable for use in A01.22 specifications.

for not less than ½ h, and remove from the furnace and cool in air. Subsequently, artificially age in the range from 1000 to 1200 °F [540 to 650 °C] for not less than ½ h, and cool at any convenient rate.

5.4.3.2 *Quenched-and-Precipitation Heat Treated*—Austenitize in the range from 1600 to 1725 °F [870 to 940 °C] for not less than ½ h and quench in a suitable liquid medium by immersion; artificially age in the range from 1000 to 1225 °F [540 to 665 °C] for not less than ½ h, and cool at any convenient rate.

## 6. Chemical Composition

### 6.1 Heat Analysis:

6.1.1 A chemical heat analysis in accordance with Specification **A961/A961M** shall be made and conform to the requirements as to chemical composition prescribed in **Table 1**. Leded steels shall not be permitted.

### 6.2 Product Analysis:

6.2.1 The purchaser may make a product analysis on products supplied to this specification in accordance with Specification **A961/A961M**.

## 7. Mechanical Properties

### 7.1 Tension Tests:

7.1.1 *Requirements*—The material shall conform to requirements for tensile properties in **Table 2**.

7.1.1.1 The test specimen shall be obtained from a rough or finished forging, or prolongation thereof. For forgings under 10 000 lbs, at time of heat treatment, it may be obtained from separately forged test blanks from the same heat of steel as the production forgings. The test blank shall be reduced by forging in a manner similar to that for the products represented, and shall receive approximately the same hot working and reduction and the same heat treatment as the finished products

represented. The test material shall be treated in the same furnace at the same time as the forging it represents, subject to the requirements of **7.1.2.1**.

7.1.1.2 The test specimen shall represent all forgings from the same heat and heat-treatment load whose maximum thicknesses do not exceed the thickness of the test forging or blank by more than ¼ in. [6 mm].

7.1.2 *Number of Tests*—One tension test at room temperature shall be made in accordance with **7.1.1.2** from each heat in each heat-treatment load.

7.1.2.1 If heat treatment is performed in either a continuous or a batch-type furnace controlled within ±25 °F [±14 °C] of the required heat-treatment temperature and equipped with recording pyrometers so that complete records of heat treatment are available and if the same heat-treating cycles are used on the forgings represented by the tension test, then one tension test from each heat shall be required, instead of one tension test from each heat in each heat treatment load in accordance with **7.1.1.2**.

7.1.3 *Test Locations and Orientations*—The test specimen shall be removed from the heaviest section of the forging or test blank, at locations described in **7.1.3.1**, **7.1.3.2**, **7.1.3.5** or as close to these locations as practical, subject to forging size and geometry.

7.1.3.1 For forgings or test blanks having a maximum heat-treated thickness, *T*, of 2 in. [50 mm] or less, the longitudinal axis of the test specimen shall be taken at mid-thickness and its mid-length shall be at least 2 in. [50 mm] from all other heat treated surfaces, exclusive of the *T* dimension surfaces. (This is normally referred to as ½ *T* by 2 in. [50 mm]). See **Fig. 1** for test specimen location in separately forged test blanks.

7.1.3.2 For forgings or test blanks having a maximum heat-treated thickness, *T*, greater than 2 in. [50 mm]:

**TABLE 2 Tensile Properties at Room Temperature<sup>A</sup>**

	Grades							
	LF1 and LF5	LF2	LF3	LF6		LF9	LF787	
	Class 1	Classes 1 and 2	Classes 1 and 2 LF5 Class 2	Class 1	Classes 2 and 3		Class 2	Class 3
Tensile strength, ksi [MPa]	60–85 [415–585]	70–95 [485–655]	70–95 [485–655]	66–91 [455–630]	75–100 [515–690]	63–88 [435–605]	65–85 [450–585]	75–95 [515–655]
Yield strength, min, ksi [MPa] <sup>B</sup>	30 [205]	36 [250]	37.5 [260]	52 [360]	60 [415]	46 [315]	55 [380]	65 [450]
Elongation:								
Standard round specimen, or small proportional specimen, min % in 4D gauge length	25	22	22	22	20	25	20	20
Strip specimen for wall thickness ⅝ in. [7.94 mm] and over and for all small sizes tested in full section; min % in 2 in. [50 mm]	28	30	30	30	28	28	28	28
Equation for calculating min elongation for strip specimens thinner than ⅝ in. [7.94 mm]; min % in 2 in. [50 mm]	48 <i>t</i> + 13	48 <i>t</i> + 15	48 <i>t</i> + 15	48 <i>t</i> + 15	48 <i>t</i> + 13	48 <i>t</i> + 13	48 <i>t</i> + 13	48 <i>t</i> + 13
<i>t</i> = actual thickness in inches								
Reduction of area, min, % <sup>C</sup>	38	30	35	40	40	38	45	45

<sup>A</sup> See **7.3** for hardness tests.

<sup>B</sup> Determined by either the 0.2 % offset method or the 0.5 % extension under load method.

<sup>C</sup> For round specimens only.

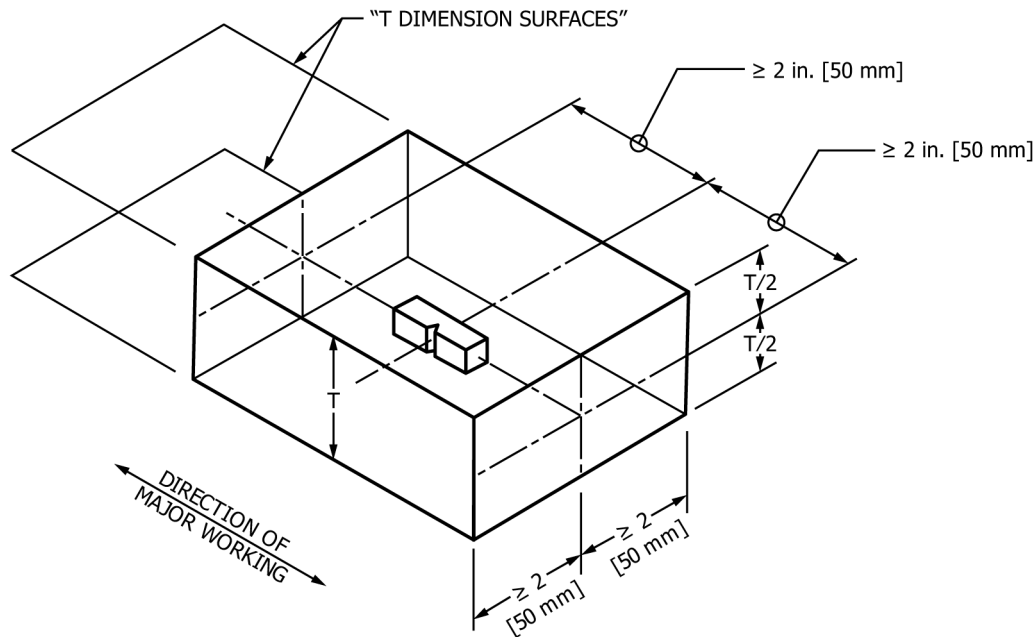

NOTE 1—For clarity, only the Charpy V-notch specimen is shown in Figs. 1-4. The tension test specimen shall be located such that its orientation and the mid-length location meet the same requirements as that for the Charpy V-notch test specimen shown in Figure 1.

FIG. 1 Separately Forged Test Bar for Forgings with  $T \leq 2$  in. [50 mm]

iTeh Standards

(1) Except as stated in 7.1.3.2 (2) and 7.1.3.2 (3), the central axis of the test specimen shall be taken at least  $\frac{1}{4} T$  from the nearest heat-treated surface and its mid-length shall be at least 2 in. [50 mm] from all other heat treated surfaces, exclusive of the  $T$  dimension surfaces. See Fig. 2 for test specimen location in separately forged test blanks.

(2) For quenched-and-tempered or for quenched-and-precipitation-heat-treated forgings, the central axis of the test specimen shall be taken at least  $\frac{1}{4} T$  from the nearest heat-treated surface, and the mid-length of the test specimen shall be at least  $T$  from all other heat treated surfaces, exclusive of the  $T$  dimension surfaces. See Fig. 3 for test specimen location in separately forged test blanks.

(3) For quenched-and-tempered or for quenched-and-precipitation-heat-treated forgings that have a  $W/T$  ratio  $< 2$ , the central axis of the test specimen shall be taken at least  $\frac{1}{4} T$  from the nearest heat-treated surface, and at mid-width of the forging, where  $W$  is the width of the forging. The test specimen mid-length shall be at least  $T$  from the ends of the forging or test blank. See Fig. 4 for test specimen location in separately forged test blank.

7.1.3.3 *Metal Buffers*—The required distances from heat treated surfaces for the test locations described in 7.1.3.1 and 7.1.3.2 may be obtained with metal buffers instead of integral expansions. Buffer material may be carbon or low alloy steel, and shall be joined to the forging with a partial penetration weld that seals the buffered surface. Specimens shall be located at  $\frac{1}{2}$  in. [13 mm] minimum from the buffered surface of the forging. Buffers shall be removed after heat treatment and the welded areas subjected to magnetic particle test to assure freedom from cracks unless the welded areas are completely removed by subsequent machining.

7.1.3.4 The test specimen shall have its longitudinal axis located parallel to the direction of major working of the forging or test blank.

7.1.3.5 With prior purchaser approval, tests may be taken at a depth ( $t$ ) corresponding to the distance from the area of significant loading to the nearest heat treated surface and at least twice this distance ( $2t$ ) from any second surface. However, the test depth shall not be nearer to one treated surface than  $\frac{3}{4}$  in. [19 mm] and to the second treated surface than  $1\frac{1}{2}$  in. [38 mm]. This method of test location would normally apply to contour-forged parts, or parts with thick cross-sectional areas where  $\frac{1}{4} T \times T$  testing (7.1.3.2) is not practical. Sketches showing the exact test locations shall be approved by the purchaser when this method is used.

7.1.4 *Test Method*—Testing shall be performed as specified in Specification A961/A961M. The test specimen shall be as large as is practicable and shall be machined to the form and dimensions in Specification A961/A961M. When seamless tubular materials are used, testing shall be performed on longitudinal specimens as specified in Specification A961/A961M.

7.2 *Impact Test:*

7.2.1 *Requirements*—The material shall conform to the requirements for impact properties in Table 3 when tested at the applicable standard temperature in Table 4 within the limits of 7.2.4.2 and 7.2.4.3. When subsize specimens are used, the impact energy values obtained shall conform to Table 5 at energy values proportional to standard size. Exceptions to this requirement are permissible when Supplementary Requirement S1 is specified by the purchaser. Impact tests may be made at temperatures different from those in Table 4, provided that the

**TABLE 3 Charpy V-Notch Energy Requirements for Standard Size [10 by 10 mm] Specimens**

Grade	Minimum Impact Energy Required for Average of Each Set of Three Specimens, ft-lbf [J]	Minimum Impact Energy Permitted for One Specimen only of a Set, ft-lbf [J]
LF1 and LF9	13 [18]	10 [14]
LF2, Class 1	15 [20]	12 [16]
LF3, Class 1	15 [20]	12 [16]
LF5 Class 1 and 2	15 [20]	12 [16]
LF787 Classes 2 and 3	15 [20]	12 [16]
LF6, Class 1	15 [20]	12 [16]
LF2, Class 2	20 [27]	15 [20]
LF3, Class 2	20 [27]	15 [20]
LF6, Classes 2 and 3	20 [27]	15 [20]

**TABLE 4 Standard Impact Test Temperature for Standard Size [10 by 10 mm] Specimens**

Grade	Test Temperature, °F [°C]
LF1	-20 [-29]
LF2 Class 1	-50 [-46]
LF2 Class 2	-0 [-18]
LF3, Classes 1 and 2	-150 [-101]
LF5, Classes 1 and 2	-75 [-59]
LF6, Classes 1 and 2	-60 [-51]
LF6, Class 3	0 [-18]
LF9	-100 [-73]
LF787, Class 2	-75 [-59]
LF787 Class 3	-100 [-73]

**TABLE 5 Minimum Equivalent Absorbed Energy ft-lbf (J) for Various Specimen Sizes<sup>A</sup>**

Standard Size [10 by 10 mm]	¾ size [10 by 7.5 mm]	⅔ size [10 by 6.6 mm]	½ size [10 by 5 mm]	⅓ size [10 by 3.3 mm]	¼ size [10 by 2.5 mm]
15 [20]	12 [16]	10 [14]	8 [11]	5 [7]	4 [6]
13 [18]	10 [14]	9 [12]	7 [10]	5 [7]	4 [6]
12 [16]	10 [14]	9 [12]	7 [10]	4 [6]	3 [5]
10 [14]	8 [11]	7 [10]	5 [7]	3 [5]	3 [5]

<sup>A</sup> Straight-line interpolation for intermediate values is permitted.

test temperature is at least as low as the intended service temperature, and that the forging is suitably marked to identify the reported test temperature.

7.2.1.1 The test specimens shall be machined from material obtained as in 7.1.

7.2.2 *Number of Tests*—Three specimens shall constitute one test set. There shall be the same number of test sets as tension tests in 7.1.2.

7.2.3 *Test Locations and Orientations*—The test specimen shall be located and oriented as described in 7.1.3. The area under the notch of the impact test specimen shall be used to locate the specimen with respect to the second heat-treated surface. The base of the notch shall be perpendicular to the nearest heat-treated surface.

7.2.4 *Test Method*—The notched bar impact test shall be made in accordance with the procedure for the Charpy V-notch type test as specified in Specification A961/A961M.

7.2.4.1 Standard size specimens shall be used for the impact test. Where the material is of insufficient thickness, or the

shape of the forging precludes standard size, the largest obtainable subsize specimen shall be used.

7.2.4.2 Where subsize specimens are used and represent forged material with thicknesses equal to or greater than 0.394 in. [10 mm], and where the largest obtainable specimen has a width along the notch of at least 8 mm, such specimen shall be tested at the temperature in Table 4. Where the largest obtainable specimen has a width along the notch less than 8 mm, the temperature for testing shall be lower than the temperature in Table 4 by the amount shown in Table 6 for the actual specimen width tested.

7.2.4.3 Where subsize specimens are used and represent forged material with thicknesses less than 0.394 in. [10 mm], and where the largest obtainable specimen has a width along the notch of at least 80 % of the forging thickness, the specimen shall be tested at the temperature in Table 4. Where the largest obtainable specimen has a width along the notch of less than 80 % of the material thickness, the temperature for testing shall be lower than the temperature in Table 4 by an amount equal to the difference (referring to Table 6) between the temperature reduction corresponding to the thickness of the material represented, and the temperature reduction corresponding to the specimen width actually tested.

**7.3 Hardness Test:**

7.3.1 Except when only one forging is produced, a minimum of two forgings shall be hardness tested per batch or continuous run as defined in 7.1.2.1 to ensure that hardness of the forgings does not exceed 197 HBW after heat treatment for mechanical properties. The hardness measurements shall be made as specified in Specification A961/A961M. When only one forging is produced, it shall be hardness tested to ensure that it meets the 197 HBW maximum of this specification. The purchaser may verify that this requirement has been met by testing at any location on the forging, provided that such testing does not render the forging useless.

**8. Hydrostatic Test**

8.1 Forgings manufactured under this specification shall be capable of passing a hydrostatic test compatible with the rating

**TABLE 6 Charpy Impact Test Temperature Reduction Below Table 4 Test Temperature when the Subsize Charpy Impact Width along Notch is Less than 80% of the Forging Thickness**

Size of Bar	Thickness of the Material Represented (see 7.2.4.3), or Charpy, Impact Specimen Width Along the Notch <sup>A</sup> , in. [mm]	Temperature Reduction, °F [°C]
Standard	0.394 [10]	0 [0]
Standard	0.354 [9]	0 [0]
Standard	0.315 [8]	0 [0]
¾-size	0.295 [7.5]	5 [3]
¾-size	0.276 [7]	8 [5]
⅔-size	0.262 [6.67]	10 [6]
⅔-size	0.236 [6]	15 [8]
½-size	0.197 [5]	20 [11]
½-size	0.158 [4]	30 [17]
⅓-size	0.131 [3.33]	35 [20]
⅓-size	0.118 [3]	40 [22]
¼-size	0.099 [2.5]	50 [28]

<sup>A</sup> Straight-line interpolation for intermediate values is permitted.

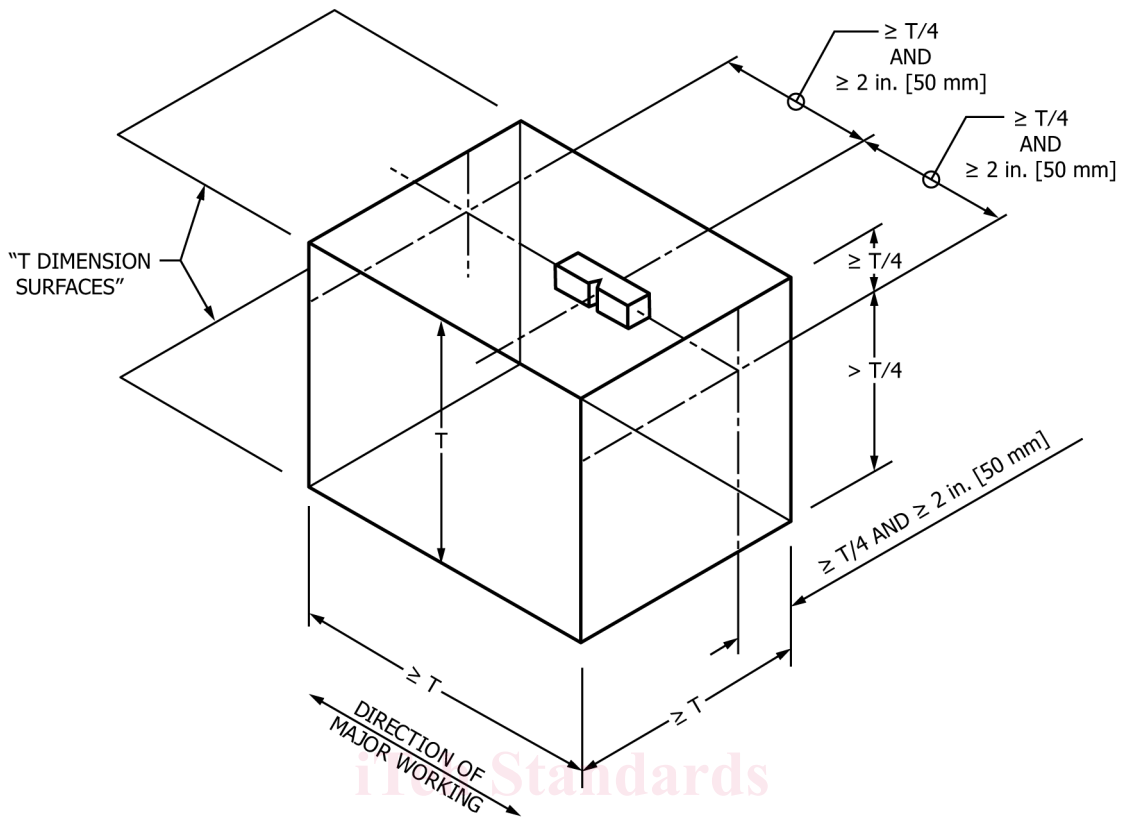

FIG. 2 Separately Forged Test Bar for Forgings with  $T > 2$  in. [50 mm] and Not Quenched and Tempered

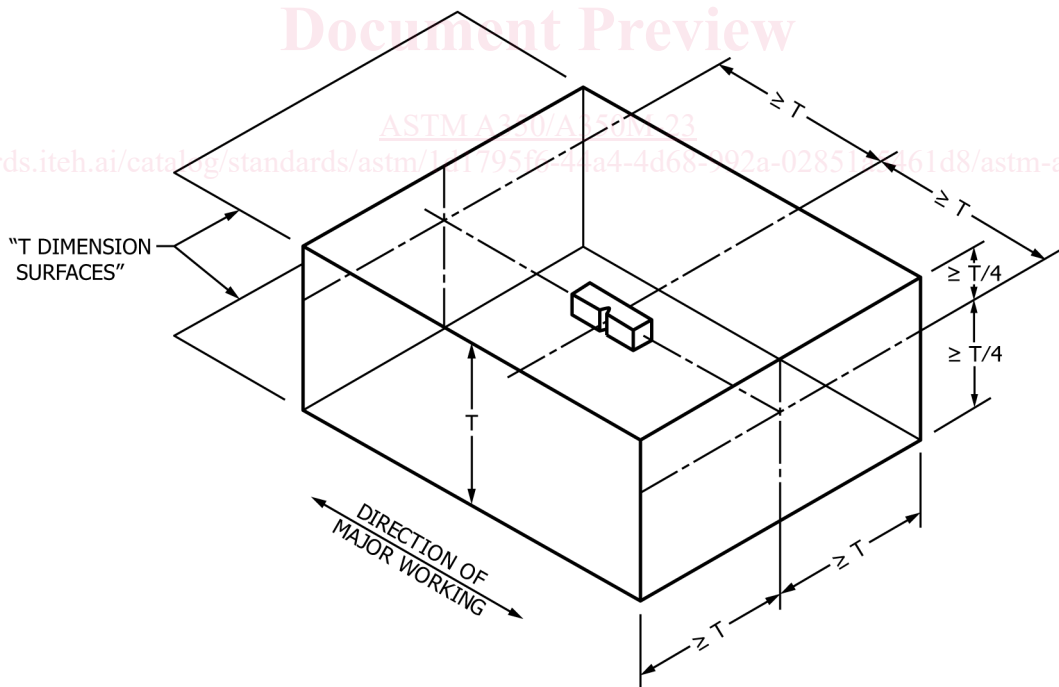

FIG. 3 Separately Forged Test Blank for Forgings with  $T > 2$  in. [50 mm] and Quenched and Tempered or Quenched and Precipitation-Heat Treated

of the finished item. Such tests shall be conducted by the