



Designation: **D4445–10 (Reapproved 2019) D4445 – 23**

Standard Test Method for Fungicides for Controlling Sapstain and Mold on Unseasoned Lumber (Laboratory Method)¹

This standard is issued under the fixed designation D4445; the number immediately following the designation indicates the year of original adoption or, in the case of revision, the year of last revision. A number in parentheses indicates the year of last reapproval. A superscript epsilon (ϵ) indicates an editorial change since the last revision or reapproval.

1. Scope

1.1 This (laboratory) test method is used for determining the minimum concentration of fungicide, or formulation of fungicides, that is effective in preventing biodeterioration by sapstain fungi and molds in selected species of wood under optimum laboratory conditions.

NOTE 1—From the results of this test, commercial treating solution concentrations cannot be estimated without further field tests.

1.2 The requirements for test materials and procedures are discussed in the following order:

	Section
Summary of Test Method	4
Apparatus	6
Reagents	7
Wood	8
Test Fungi	9
Culture Media	10
Preparation of Inoculum	11
Preparation of Test Chambers	12
Treatment of Samples	13
Inoculation and Incubation	14
Evaluation of the Test	15
Report	16

1.3 The values stated in SI units are to be regarded as standard. No other units of measurement are included in this standard.

1.4 *This standard does not purport to address all of the safety concerns, if any, associated with its use. It is the responsibility of the user of this standard to establish appropriate safety, health, and environmental practices and determine the applicability of regulatory limitations prior to use.*

1.5 *This international standard was developed in accordance with internationally recognized principles on standardization established in the Decision on Principles for the Development of International Standards, Guides and Recommendations issued by the World Trade Organization Technical Barriers to Trade (TBT) Committee.*

¹ This test method is under the jurisdiction of ASTM Committee D07 on Wood and is the direct responsibility of Subcommittee D07.06 on Treatments for Wood Products. Current edition approved July 1, 2019 April 15, 2023. Published August 2019 May 2023. Originally approved in 1984. Last previous edition approved in 2015 2019 as D4445–10(2015); D4445 – 10 (2019). DOI: 10.1520/D4445-10R19-10.1520/D4445-23.

2. Referenced Documents

2.1 ASTM Standards:²

[D9 Terminology Relating to Wood and Wood-Based Products](#)

[D1165 Nomenclature of Commercial Hardwoods and Softwoods](#)

[D1193 Specification for Reagent Water](#)

[D5590 Test Method for Determining the Resistance of Paint Films and Related Coatings to Fungal Defacement by Accelerated Four-Week Agar Plate Assay](#)

3. Terminology

3.1 *Definitions*—For definitions of terms used in this test method, refer to Terminologies [D9](#) and [D1165](#).

4. Summary of Test Method

4.1 Unseasoned sapwood specimens are treated either by spraying with, or by immersing in, solutions or dispersions of a fungicide formulation prepared at five or more concentration levels. The specimens are exposed to sapstain fungi and molds. Options for testing the toxicity of fungicides include testing against individual fungi or against several fungi by using a mixed spore suspension for the inoculation of the specimens.

4.2 The intensity of surface fungal growth is estimated after incubation and the results used to determine the minimum chemical treatment concentration giving zero growth (CGo).

5. Significance and Use

5.1 This test method is useful as a screening procedure for selecting fungicides or formulations for more rigorous field evaluation.

6. Apparatus

6.1 *Incubation Room (or Incubation Cabinet)*, maintained at a temperature of $25 \pm 1^\circ\text{C}$; $25^\circ\text{C} \pm 1^\circ\text{C}$, and relative humidity between ~~70~~70 % and 80 %.

6.2 *Steam Sterilizer*.

[ASTM D4445-23](#)

<https://standards.iteh.ai/catalog/standards/sist/cabfbc76-2299-4651-b4e5-37f6d48ef202/astm-d4445-23>

6.3 *Containers*:

6.3.1 *Sterile Petri Dishes*, with minimum size of ~~140~~140 mm (diameter) by 20 mm (height) with lid or,

6.3.2 *Aluminum Pans*, with minimum size of ~~240~~240 mm by ~~100~~240 mm by 100 mm by 20 mm (height) with aluminum foil cover.

6.4 *Spacers*:

6.4.1 *U-Shaped Glass Rod* ~~or~~ *Straight Glass Rods*, with 3 mm diameter or,

6.4.2 *Polyethylene Mesh*, cut to cover the bottom of the selected container(s).

7. Reagents

7.1 *Purity of Water*—Reference to water shall be understood to mean sterile reagent water conforming to Type IV of Specification [D1193](#).

8. Wood

8.1 *General Properties*—The wood species to be tested shall be selected on the basis of their susceptibility to ~~staining~~staining/

² For referenced ASTM standards, visit the ASTM website, www.astm.org, or contact ASTM Customer Service at service@astm.org. For *Annual Book of ASTM Standards* volume information, refer to the standard's Document Summary page on the ASTM website.

mold fungi (pine or spruce species are preferred)—preferred when evaluating softwoods). Sapwood of the selected wood species, unseasoned (moisture content higher than 40 %), free of knots, visible decay, sapstain, and mold, shall be used (Note 2). If the fungicide is to be used to protect hardwood, the inclusion of sapwood from a ~~hardwood species~~ susceptible hardwood species, such as red oak or hickory, is recommended.

NOTE 2—If wood for the test is collected in a sawmill where logs are stored in water, it is necessary to collect lumber from at least three different logs since depletion of nutrients during water storage may strongly affect the growth of molds and staining fungi. Ensure that the lumber collected in a sawmill has not been treated with a sapstain and mold preventive, and if there is any doubt, at least 10 mm of surface wood must be removed and discarded.

8.2 *Size of Specimens*—Specimens shall be 77 mm by 20 mm in cross section and 70 mm long.

8.3 *Preparation of Specimens*—Within two days of collecting, the samples shall be cut from the wood using a sharp saw blade. To prevent drying, the specimens shall be stored in polyethylene bags. For storage longer than one day, but less than one year, tightly packed specimens shall be frozen (-20°C (-20°C or lower) in polyethylene ~~bags~~ bags. For these longer storage cases, the contents of one bag shall be limited to as many specimens as are used for a single experiment.

9. Test Fungi³

9.1 Hardwoods:

9.1.1 Sapstain Fungi:

9.1.1.1 *Diplodia natalensisgossypina* ~~P. Evans-Cooke~~ (Pole-Evans, anamorph) (ATCC 34643).

9.1.1.2 *Davidsoniella virescens* (Davison) de Beer et al., a form of *C. coerulescens* found on American hardwoods.

9.1.1.3 *Aureobasidium pullulans* (~~d. By~~) Arnaud (de Bary) Arnaud (ATCC 16624).

9.1.2 Mold Fungi:

9.1.2.1 *Trichoderma pseudokoningii* Rifai (ATCC 26801).

9.1.2.2 *Cephaloascus fragrans* Hanawa (ATCC 12091).

9.1.2.3 *Gliocladium roseum* Clonostachys rosea (~~Link~~) Bainier (~~Link~~:Fries) (ATCC 10521).

9.2 Softwoods:

9.2.1 Sapstain Fungi:

9.2.1.1 *Diplodia natalensisgossypina* ~~P. Evans-Cooke~~ (Pole-Evans, anamorph) (ATCC 34643).

9.2.1.2 *Ceratocystis pilifera* (Fr.) C. Moreau (ATCC 15457).

9.2.1.3 *Aureobasidium pullulans* (~~d. By~~) (de Bary) Arnaud (ATCC 16624).

9.2.2 Mold Fungi:

9.2.2.1 *Trichoderma pseudokoningii* (Rifai) (ATCC 26801).

9.2.2.2 *Cephaloascus fragrans* Hanawa (ATCC 12091).

9.2.2.3 *Gliocladium roseum* Clonostachys rosea (~~Link~~) Bainier (~~Link~~:Fries) (ATCC 10521).

9.3 *General Consideration*—In addition to the above fungi, others that are known to cause ~~discoloration on wood species used~~

³ The following numbers refer to standard strains of test fungi maintained in the American Type Collection (ATCC), P.O. Box 1549, Manassas, VA 20108, www.atcc.org.

~~in test include, for example, growth/dicoloration on wood which may also be used for testing include, *Cytospora**Alternaria* sp. (Pine); sp.; *Phialophora**Aspergillus brasiliensis* sp.; Varga et al. (ATCC 9642); *Graphium**Aspergillus niger* van Tieghem (ATCC 6275); *Aspergillus* sp.; *Ceratocystis* sp.; *Alternaria**Cytospora* sp. (Pine); *Graphium* sp.; *Penicillium citrinum* Thom (ATCC 9849); *Penicillium* sp.; *Aspergillus**Phialophora* sp.; *Trichoderma virens* (Miller et al.) von Arx, anamorph (ATCC 9645); *Trichoderma* sp.~~

10. Culture Media

10.1 *Agar Substrate*—For both stock culture tube and ~~petri~~Petri dish cultures of the test fungi, use a nutrient medium: that is, malt extract agar (MEA, 2 % malt extract plus 2 % agar), potato dextrose agar (PDA, 0.4 % potato starch, 2 % dextrose plus 2 % agar), or similar commercial mixtures of MEA or PDA prepared in accordance with manufacturer ~~instructions.~~instructions (for example, culturing substrate and growth conditions as defined by the ATCC). PDA stimulates sporulation in some sapstain fungi (for example, *Aureobasidium pullulans*). Sterilize the medium at ~~121°C,~~121 °C, 0.1 MPa, for 20 min.

11. Preparation for Inoculum

11.1 ~~If the toxicity of a fungicide is being tested against individual fungi, maintain~~Maintain aseptic conditions when preparing the spore suspension; ~~if the general effectiveness of a fungicide is being tested using a mixed spore suspension, aseptic conditions are unnecessary.~~individual and mixed spore suspensions. For laboratory experiments requiring a relatively small volume (about ~~100 mL~~) 100 mL) of inoculum, preparation using only the stock test tube cultures is an option. For larger volumes of inoculum, prepare from cultures grown on ~~petri dishes.~~Petri dishes. Use only freshly prepared cultures to ensure vigor of the fungi.

NOTE 3—Before using any stock test tube culture, reinoculate new tubes to confirm growth and for future use.

11.2 For the preparation of a spore suspension, add 5 mL of sterile water to each culture tube or 10 mL to ~~petri~~Petri dishes, and gently rub the surface of the MEA or PDA culture with a blunt glass rod to loosen the spores. After collecting the spores and combining them with other similarly collected spores, if desired, adjust the water volume to that required. Although it is a good practice to prepare fresh spore suspensions just before use, their storage for up to one week with refrigeration is permissible.~~Carefully aspirate the spore suspension from plate using a sterile pipet, avoiding collection of mycelial fragments or agar.~~

11.3 For nonsporulating cultures, obtain a mycelial suspension for use by aseptically scraping the surface mycelium off and blending it with sterile water.

11.4 After collecting the spores, shake or gently vortex to liberate spores and break up spore clumps. Filter spore suspension through a sterile funnel containing a thin layer of glass wool (see methods in Test Method [D5590](#)).

11.5 Using a counting chamber, adjust the water volume such that the spore suspension contains 0.8 to 1.2 × 10⁶ spores/mL. For mixed spore suspensions, combine equal volumes such that the final mixture contains equivalent spore concentrations from each of the test fungi selected.

NOTE 4—Certain test fungi may not be amenable for use in mixed spore suspensions (for example, *A. pullulans*) which should be considered during experimental planning.

11.6 Although it is a good practice to prepare fresh spore suspensions just before use, their storage for up to one week with refrigeration is permissible.

11.7 To evaluate a fungicide use at least six test fungi (three sapstain and three mold) individually, as well as one mixed spore suspension of selected fungi.

12. Preparation of Test Chambers

12.1 Test chambers may consist of Petri dishes or aluminum containers. To maintain high humidity in the ~~petri dishes~~containers during the test period, place eight to ten layers of sterile absorbent paper on the bottom of each ~~dish~~container. Wet the papers with sterile water until free water appears, and press out any air bubbles trapped under and between the paper ~~disks~~layers. Place a sterile U-shaped glass rod (3 mm in diameter) (Fig. 1) or polyethylene mesh spacer (Fig. 2) on top of the saturated papers in a sterile ~~petri dish~~Petri dish. For aluminum containers, place two straight rods (3 mm in diameter by 200 mm long) or polyethylene mesh spacer over saturated papers. Maintain aseptic conditions throughout.

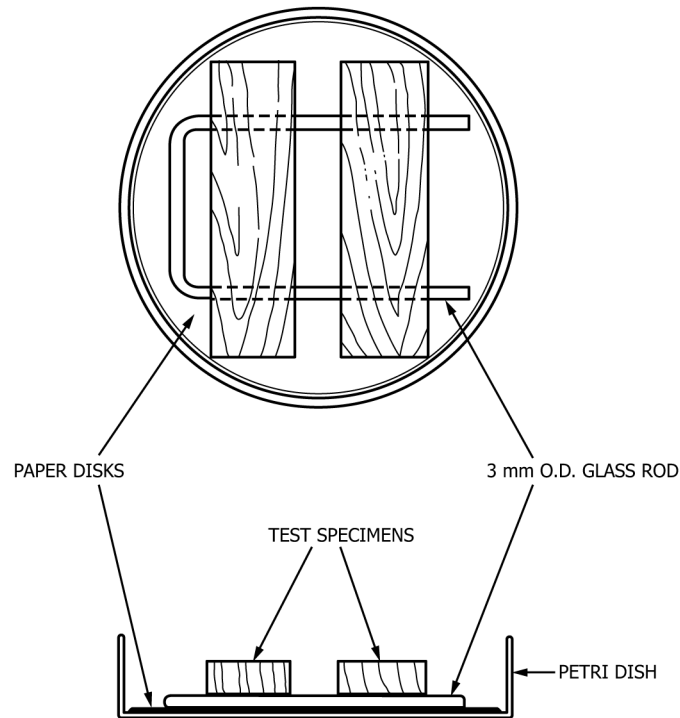

FIG. 1 Arrangement of Treated Wood Specimens on Glass Rod Within the Petri Dishes Before Incubation

iteh Standards
(<https://standards.iteh.ai>)

12.2 *Aluminum Containers*—To maintain high humidity in the containers, treat as with the petri dishes. Instead of a U-shaped glass rod however, place two straight rods (3 mm in diameter by 200 mm long) or a polyethylene mesh spacer on top of the saturated papers. Sterilize if required.

13. Treatment of Specimens

ASTM D4445-23

<https://standards.iteh.ai/catalog/standards/sist/cabfbc76-2299-4651-b4e5-37f6d48ef202/astm-d4445-23>

13.1 *Specimens*—If the wood samples were stored frozen, allow them to thaw in the polyethylene bags. Because of the variation in the susceptibility of wood to fungi, distribute an equal number of specimens from each log, into each treatment per fungus. If specimens were taken from lumber where log identity is not available, select the specimens randomly for testing. Autoclave the specimens before treatment at 121°C ; 121°C , 0.1 MPa, for 20 min.

13.2 *Number of Specimens*—Use a minimum of ten specimens per concentration of a fungicide for each fungus tested. Also, use a minimum of ten untreated control specimens for each fungus tested.

13.3 *Preparation of Treating Solution*—Evaluate each fungicide using at least five concentrations. Select the lowest concentration of a fungicide or formulation to be below the expected effective strength and each of the following concentrations shall be twice the previous concentration. Start the preparation of the set of concentrations of each fungicide by preparing the highest concentration in an amount equal to twice the volume required for treatment of the samples. Then dilute half of this preparation with an equal volume of water to obtain the next preparation. Therefore, a serial set of concentrations is prepared by continuing the dilutions in this way.

13.4 *Treating Procedure*—Carry out the treatment in a 600-mL glass beaker (Fig. 3). Place two unused test pieces edgewise on the bottom of the beaker, and the specimens, four or five in a layer, also on edge, crosswise on the previous layers until they reach the top, but not extending above the rim of the beaker. Holding down the specimens with a finger bearing down on a watch glass, pour the prepared solution into the beaker. After 15 s, pour the solution out, still holding the specimens down so that they cannot move. Similarly, treat untreated control specimens with water. After the treatment, tightly cover the beaker with a piece of plastic sheet to prevent drying, and store overnight. This allows draining of excess solution and time for the fungicide to be deposited or fixed in the wood before inoculation.