



Designation: F588 – 17 (Reapproved 2023)

Standard Test Methods for Measuring the Forced Entry Resistance of Window Assemblies, Excluding Glazing Impact¹

This standard is issued under the fixed designation F588; the number immediately following the designation indicates the year of original adoption or, in the case of revision, the year of last revision. A number in parentheses indicates the year of last reapproval. A superscript epsilon (ϵ) indicates an editorial change since the last revision or reapproval.

1. Scope

1.1 These test methods cover the ability of window assemblies of various types to restrain, delay, or frustrate forced entry.

1.2 For purposes of these test methods, window assemblies are defined as described in 1.2.1 – 1.2.5 and as shown in Fig. 1. Window assemblies with a combination of operable sash and fixed panes (lites) shall be classified and tested separately for each type.

1.2.1 *Type A*—A window assembly which incorporates one or more sash that open by *sliding*, either vertically or horizontally within the plane of the wall.

1.2.2 *Type B*—A window assembly which incorporates one or more sash that are *hinged* at or near two corners of the sash and that open toward the exterior (outswinging) or toward the interior (inswinging).

1.2.3 *Type C*—A window assembly which incorporates one or more sash that are *pivoted* so that part of the sash opens toward the interior and part of it opens toward the exterior.

1.2.4 *Type D*—A window assembly which incorporates one or more *fixed* panes (lites) or stationary sash that are designed not to open.

1.2.5 *Type E*—A window assembly which incorporates a series of overlapping horizontal louvers that are pivoted simultaneously by a common actuator so that the bottom edge of each louver swings outward and the top edge swings inward during operation.

NOTE 1—See Fig. 1 for graphic depiction of window assembly types.

1.3 The values stated in inch-pound units are to be regarded as standard. The values given in parentheses are mathematical conversions to SI units that are provided for information only and are not considered standard.

1.4 *This standard does not purport to address all of the safety concerns, if any, associated with its use. It is the responsibility of the user of this standard to establish appropriate*

appropriate safety, health, and environmental practices and determine the applicability of regulatory requirements prior to use.

1.5 *This international standard was developed in accordance with internationally recognized principles on standardization established in the Decision on Principles for the Development of International Standards, Guides and Recommendations issued by the World Trade Organization Technical Barriers to Trade (TBT) Committee.*

2. Referenced Documents

2.1 *ASTM Standards:*²

E631 Terminology of Building Constructions

E699 Specification for Agencies Involved in Testing, Quality Assurance, and Evaluating of Manufactured Building Components

2.2 *AAMA Standard:*³

AAMA 1302.5-76 Voluntary Specifications for Forced Entry Resistant Aluminum Prime Windows

2.3 *CAWM Standards:*³

CAWM 301-90 Forced Entry Resistance Tests for Windows

CMBSO 1-79 California Model Building Security Ordinance

3. Terminology

3.1 *Definitions*—Definitions for standard terminology can be found in Terminology **E631**.

3.2 *Definitions of Terms Specific to This Standard:*

3.2.1 *locking device(s) (lock), n*—one or more components of a window assembly intended to resist the opening of movable sash or louvers from the exterior.

3.2.2 *louver, n*—a glazing component of a louver window.

3.2.3 *louver holder, n*—a component of a louver window that holds the louvers at each end and transfers the pivoting and locking forces from the actuating mechanism(s) to the louvers.

¹ These test methods are under the jurisdiction of ASTM Committee **E06** on Performance of Buildings and are the direct responsibility of Subcommittee **E06.51** on Performance of Windows, Doors, Skylights and Curtain Walls.

Current edition approved May 1, 2023. Published May 2023. Originally approved in 1979. Last previous edition approved in 2017 as F588 – 17. DOI: 10.1520/F0588-17R23.

² For referenced ASTM standards, visit the ASTM website, www.astm.org, or contact ASTM Customer Service at service@astm.org. For *Annual Book of ASTM Standards* volume information, refer to the standard's Document Summary page on the ASTM website.

³ Available from American Architectural Manufacturers Association (AAMA), 1827 Walden Office Square, Suite 550, Schaumburg, IL 60173-4268, <http://www.aamanet.org>.

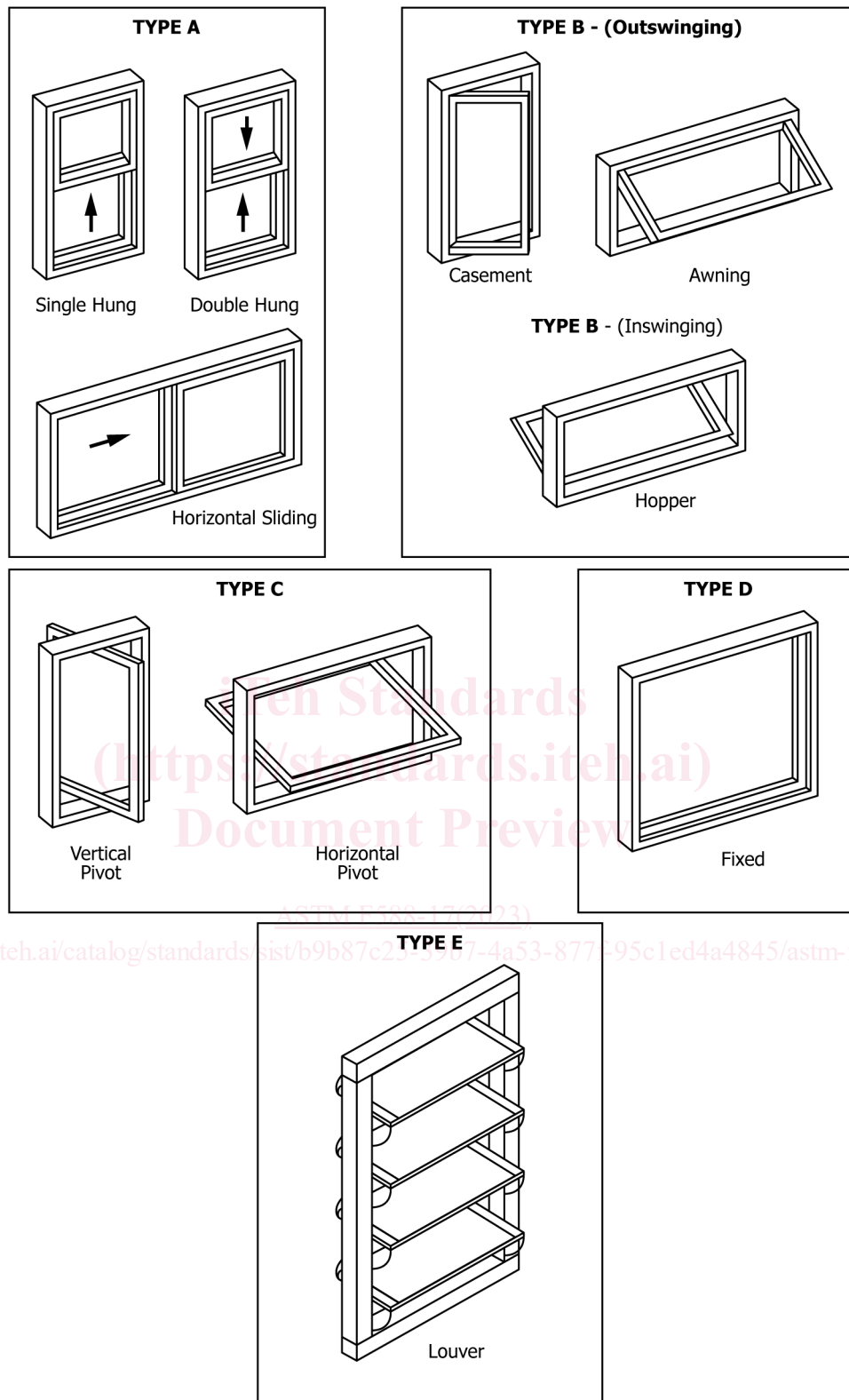

FIG. 1 Typical Window Types (viewed from the exterior)

3.2.4 *sash operator, n*—a component of the window assembly that is used to move, pivot, or adjust the position of a movable sash within the window frame. (The sash operator in some window assemblies is also a locking device.)

4. Summary of Test Method

4.1 The procedure consists of mounting a specimen into a test assembly fixture which in turn is mounted to a wall support fixture, and, after removing all exterior fasteners and loose component items, specified loads and forces are applied to the window test specimen in a prescribed sequence. Following removal of all loads, a determination is made by the laboratory technician, as defined by Section 9 of Specification E699, whether or not entry can be gained through the window test specimen from the exterior.

5. Significance and Use

5.1 These test methods are intended to establish a measure of resistance for window assemblies subjected to attacks (other than impacting glazing materials) by unskilled or opportunistic burglars. Resistance to higher levels of force generated by skilled burglary attack requires methods such as alarms, communication, or apprehension systems, or special security glazing materials more sophisticated than those evaluated by these test methods. Technicians performing the test should understand the intent of this test method and should be trained on the execution and pass/fail criteria.

5.2 Entry through a window assembly can be accomplished by impacting the glazing materials. This method does not evaluate glazing materials for breakage. Other standards must be used to evaluate forced entry by impacting the glazing.

5.3 Acceptance criteria for performance levels are a matter for authorities having specific jurisdiction to establish. Suggested guidelines are found in Annex A1.

6. Test Criteria

6.1 *Window Test Specimen*—The same window assembly shall be used for all testing and shall contain sash or louvers having the greatest height and width for which approval is sought. Each unique sash/frame or louver/frame arrangement shall be tested.

6.1.1 The construction of the window test specimen, including all hardware, components, and arrangement of sash or louvers shall be representative of that for which acceptance is desired.

6.1.2 The window test specimen shall consist of the entire assembled unit, including frame, glazing, and anchorage as supplied by the manufacturer for installation in the building.

6.1.3 Unless otherwise specified, the window test specimen shall contain annealed glass for testing and shall be single glazed if designed for either single or double glazing, or double glazed if designed exclusively for multiple glazing. Products tested with glazing materials other than annealed glass shall be used to qualify only the specific glazing material tested.

6.1.4 Windows tested with more than one locking device shall not qualify windows with fewer locking devices, regardless of size.

6.2 *Performance Criteria*—The performance level is attained if all locking devices remain engaged and entry cannot be gained during the test or upon removal of loads. If any component during testing, allowing entry, this shall be considered as failure to attain the performance level. Glazing which breaks, but does not allow entry, shall not be considered a failure to attain the performance level.

6.3 *Multiple Sash*—Window assemblies with a combination of operable sash and fixed panes (lites) shall be classified and tested separately for each type. If multiple sash within a window assembly are identical in construction and locking condition, only one sash need be tested.

6.4 *Multiple Louver*—Window assemblies with a combination of operable louvers, operable sash, or fixed panes (lites), or any combination thereof, shall be classified and tested separately for each type. If multiple louver windows within a window assembly are identical in construction and locking condition, only one louver window need be tested. If multiple louvers within a louver window are identical in construction and locking condition, only one louver need be tested.

6.5 *Test Sequence*—Perform the tests for each window test specimen in the sequence as outlined in Section 10. The sequence for testing multiple sash shall be at the discretion of the testing agency.

6.6 *Loading*—Apply test loads and forces at a rate not to exceed 10 lb/s (45 N/s). Maintain performance loads for a period of 60 s ± 5 s.

6.7 *Load Removal*—At the conclusion of each test, remove all loads before starting the next test.

7. Apparatus

7.1 *Instrumentation*—Load and time measuring devices with an accuracy of ±2 % of the full scale shall be incorporated in the test setups. The scale ranges used shall assure that the performance levels are within an accuracy of ±5 %.

7.2 *Load Attachments*—Brackets, fasteners, or other devices used in performing these tests shall be designed and attached so as to minimize their influence on the test results.

7.3 *Test Frame*—The test fixture shall be designed and constructed to accept and rigidly secure the window specimen and to provide rigid points of anchor for all test loads described in Section 10. The load bearing members of the test fixture shall be constructed to limit deflection of such members to a maximum of 1/8 in. (3 mm) under full-prescribed load.

7.4 *Tools for Disassembly*—The following tools shall be used for disassembly of the test specimen:

7.4.1 A spatula, putty knife or other non-cutting tool with a thin blade, 24 gauge stainless steel 0.024 in. ± 0.004 in. (0.6 mm ± 0.1 mm) thick, 0.78 in. ± 0.08 in. (20 mm ± 2 mm) wide, and 3.5 in. ± 0.4 in. (90 mm ± 10 mm) long. The bottom may be wrapped for safety provided the 3.5 in. ± 0.4 in. (90 mm ± 10 mm) length remains exposed.

7.4.2 Any non-powered, straight, or Phillips head screwdriver appropriate to the mechanical fastener with a maximum length of 6 in. (150 mm).

7.4.3 Standard slot-type pliers with a 6 in. to 7 in. (150 mm to 175 mm) overall length.

7.5 *Tools for Hardware Manipulation*—The following tools shall be used for manipulation of the locks of the test specimen:

7.5.1 A spatula, putty knife, or other non-cutting tool with a thin blade, 24 gauge stainless steel 0.24 in. \pm 0.004 in. (0.6 mm \pm 0.1 mm) thick, 0.78 in. \pm 0.08 in. (20 mm \pm 2 mm) wide, and 3.5 in. \pm 0.4 in. (90 mm \pm 10 mm) long. The bottom may be wrapped for safety provided the 3.5 in. \pm 0.4 in. (90 mm \pm 10 mm) length remains exposed.

7.5.2 A piece of black annealed 16 gauge straight wire at least long enough to reach from the point of insertion to the locking device(s). The properties of black annealed 16 gauge wire are described in *Machinery's Handbook*, 22nd Edition.⁴ 16 gauge wire refers to a wire diameter of 0.0625 in. (1.6 mm).⁵

8. Hazards

8.1 Glass breakage may occur during the application of loads or forces required by these test methods. Take adequate precautions to protect personnel from broken glass.

8.2 Locking devices, glass, and other window test specimen components may suddenly fail when loads and forces are applied during these test methods, causing sash to open rapidly. Take adequate precautions to protect personnel from rapidly moving weights and window test specimen components.

9. Preparation

9.1 Mount the window test specimen into a nominal 2 in. by 4 in. or 2 in. by 6 in. (40 mm by 100 mm or 40 mm by 150 mm) lumber surround fixture, in accordance with the manufacturer's written installation instructions.

9.2 Install the window test specimen into the test fixture.

9.3 Close and lock the window test specimen. Submit each operable unit to five cycles of opening, closing, and locking prior to testing.

10. Procedure

10.1 The disassembly test, hardware manipulation test, sash manipulation test, and louver manipulation test referenced in the following parts of Section 10 are fully described in **Annex A2**.

10.2 *Type A Window Assembly*:

10.2.1 Perform the disassembly test defined in **Annex A2, A2.2**. Following the completion of the disassembly test perform tests A1 through A7 as defined in **Annex A2** for the performance grade desired using the loads and times indicated in **Table A1.1** in **Annex A1**. See 6.6 for load application details. At the completion of tests A1 through A7 perform the hardware

⁴ Available from Industrial Press, Inc., 32 Haviland Street, Suite 3, South Norwalk, CT 06854.

⁵ The sole source of supply of the apparatus known to the committee at this time is McMaster-Carr, P.O. Box 740100 Atlanta, GA 30374-0100. If you are aware of alternative suppliers, please provide this information to ASTM International Headquarters. Your comments will receive careful consideration at a meeting of the responsible technical committee,¹ which you may attend.

manipulation test and the sash manipulation test defined in **Annex A2, A2.3, and A2.4**.

10.3 *Type B Window Assembly*:

10.3.1 Perform the disassembly test defined in **Annex A2, A2.2**. Following the completion of the disassembly test perform tests B1 through B3 as defined in **Annex A2** for the performance grade desired using the loads and times indicated in **Table A1.1** in **Annex A1**. See 6.6 for load application details. At the completion of tests B1 through B3 perform the hardware manipulation test and the sash manipulation test defined in **Annex A2, A2.3, and A2.4**.

10.4 *Type C Window Assembly*:

10.4.1 Perform the disassembly test defined in **Annex A2, A2.2**. Following the completion of the disassembly test perform tests C1 through C5 as defined in **Annex A2** for the performance grade desired using the loads and times indicated in **Table A1.1** in **Annex A1**. See 6.6 for load application details. At the completion of tests C1 through C5 perform the hardware manipulation test and the sash manipulation test defined in **Annex A2, A2.3, and A2.4**.

10.5 *Type D Window Assembly*:

10.5.1 Perform the disassembly test defined in **Annex A2, A2.2**.

10.5.2 If a locking device is present anywhere on the window test specimen, perform the Hardware Manipulation Test and the Sash Manipulation Test defined in **Annex A2, sections A2.3 and A2.4** and attempt to remove the glazed panel within a time limit of (T1).

10.5.3 If a locking device is not present anywhere on the window test specimen, perform the sash manipulation test defined in **Annex A2, A2.4**, from the outside between the glazed panel and the remainder of the window test specimen, attempt to gain entry by attempting to open the glazed panel by hand and manipulating it with these tools, in any combination. Conduct this test continuously for a time limit of (T1).

10.6 *Type E Window Assembly*:

10.6.1 Perform the disassembly test defined in **Annex A2 and A2.2**. Following the completion of the disassembly test perform tests E1 through E5 as defined in **Annex A2** for the performance grade desired using the loads and times indicated in **Table A1.1** in **Annex A1**. See 6.6 for load application details. At the completion of the tests E1 through E5 perform the hardware manipulation test and the louver manipulation test defined in **Annex A2, A2.3, A2.5**.

11. Report

11.1 The report shall contain a description of the results of the test(s) performed in accordance with these test methods.

11.2 The report shall also include at least the following:

- 11.2.1 Identification of the window test specimen;
- 11.2.2 Type, size, location, and number of locking devices and other hardware;
- 11.2.3 Type, location, and number of installation fasteners;
- 11.2.4 Type and thickness of glazing material;
- 11.2.5 Bill of materials;
- 11.2.6 Assembly drawings;

11.2.7 Performance level, loads, and times (L1, L2, L3, T1) used;

11.2.8 A statement as to whether the window specimen complies or not, and the grade at which it complies;

11.2.9 A description of the method of installation or installation fastening; and

11.2.10 A description of the test equipment used.

12. Precision and Bias

12.1 These test methods do not generate numerical values. They establish a pass/fail condition which cannot generate numerical values for precision and bias.

13. Keywords

13.1 fenestration; forced entry resistance; laboratory method; windows

ANNEXES

(Mandatory Information)

A1. SUGGESTED MEASURED PERFORMANCE

TABLE A1.1 Suggested Measured Performance^A

| Identifications | Grade 10 | Grade 20 | Grade 30 | Grade 40 |
|-----------------|-----------------|-----------------|------------------|------------------|
| T1 | 5 min | 5 min | 10 min | 10 min |
| L1 | 150 lbf (667 N) | 200 lbf (890 N) | 250 lbf (1112 N) | 300 lbf (1334 N) |
| L2 | 75 lbf (333 N) | 100 lbf (445 N) | 125 lbf (556 N) | 150 lbf (667 N) |
| L3 | 25 lbf (111 N) | 35 lbf (155 N) | 50 lbf (222 N) | 60 lbf (267 N) |

^A It is suggested that [Table A1.1](#) be used with the understanding that four levels of load identification are established with load identification 40 being the highest and 10 being the lowest. Use of load identifications should be selected in accordance with security objectives desired. See [6.6](#) for load application details.

iTeh Standards

NOTE A1.1—Historically there have been two other standards for the evaluation of forced entry resistance of window assemblies. They are AAMA 1302.5-76 and CAWM 301-90. The significant differences are that the AAMA standard did not include the hardware manipulation test and did require that the separation of sash and frame during the application of

the required loads not exceed ½ in. (12 mm). The CAWM test was very similar to the ASTM Test Method except that for a Grade 10 measured performance, the required load L1 was increased to 200 lbf (890 N). Those wishing to achieve compliance to these obsolete standards for code purposes may test to this standard with the noted deviations. See [Appendix X1](#) for further historical information.

[ASTM F588-17\(2023\)](#)

<https://standards.iteh.ai/catalog/standards/sist/b9b87c25-39b7-4a53-877f-95c1ed4a4845/astm-f588-172023>

A2. TESTS

A2.1 The following tests shall be performed by laboratory personnel only, as defined in Part A of Specification [E699](#).

A2.2 Disassembly Test

A2.2.1 Remove from the window test specimen all screws, glazing beads, and any other members or other mechanical fasteners that can be removed readily from the exterior within a time limit of 5 min using the tools stipulated in [7.4](#). Removal of the indicated parts shall be done carefully so as not to cause collateral damage to the specimen.

A2.3 Lock Hardware Manipulation Test

A2.3.1 Examine the window test specimen and determine a method of inserting the tools in [7.5](#) from the outside so as to contact the locking device(s). Using one technician only, attempt to gain entry by manipulating the locking device(s) with these tools in any combination without intentionally removing material from the panel or frame to facilitate access to the locking devices. Conduct this test continuously for a

time limit of (T1). Manipulation of the locking devices shall be done in a manner that will not cause collateral damage to the specimen.

A2.4 Sash Manipulation Test

A2.4.1 While attempting to open the window, lift, push, pull, or otherwise manipulate by hand from the exterior all panels to the full confines of the frame. This test shall be conducted continuously for a time limit of (T1).

A2.5 Louver Manipulation Test

A2.5.1 While attempting to open the window, lift, push, pull, or otherwise manipulate by hand from the exterior all louver panels to the full confines of the frame. The test shall be conducted continuously for a time limit of (T1).

A2.6 Type A Window Assembly Tests

A2.6.1 Perform the disassembly test defined in [Annex A2](#), section [A2.2](#).

A2.6.2 *Test A1*—With the sliding sash in the test position, a concentrated load (L1) shall be applied separately, from the exterior, to each member incorporating a locking device, at a point on the sash member within 3 in. (75 mm) of the locking device, in a direction parallel to the plane of the glass that would tend to open the window. For interior sliding sash where the locking device is mounted at the interlocking stile or rail, the load attachment point shall be at the center of the member directly opposite the member which contains the locking device. Where more than one primary lock is used, the load shall be equally divided among the locks and shall be applied simultaneously. (See Figs. A2.1 and A2.2.)

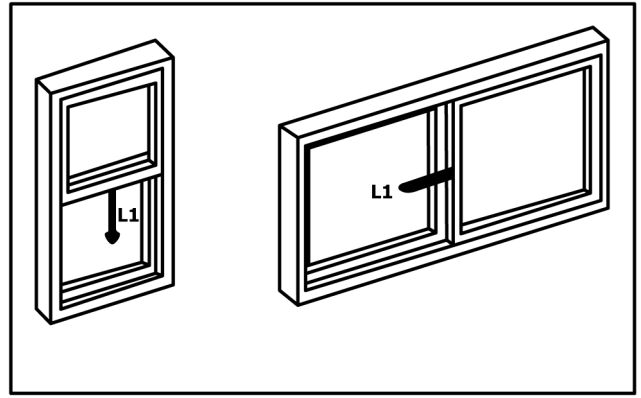

FIG. A2.2 Test A1—Exterior Sash

A2.6.3 *Test A2*—With the sliding sash in the test position, a concentrated load (L1) shall be applied separately, from the exterior, to each member incorporating a locking device, in a direction parallel to the plane of the glass that would tend to open the window, while, simultaneously, an additional concentrated load (L2) is applied to the center of the exposed interlocking stile or rail, in the direction perpendicular to the plane of the glazing material toward the interior side of the window. For interior sliding sash where the locking device is mounted at the interlocking stile or rail, the load attachment point shall be at the center of the member directly opposite the member which contains the locking device. Where more than one primary lock is used, the loads shall be equally divided among the locks and shall be applied simultaneously. (See Figs. A2.3 and A2.4.)

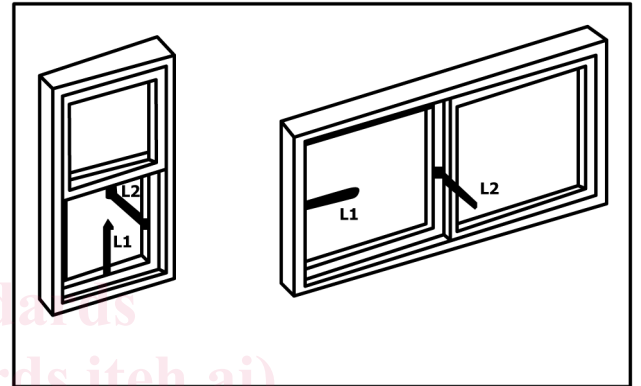

FIG. A2.3 Test A2—Interior Sash

A2.6.4 *Test A3*—With the sliding sash in the test position, a concentrated load (L1) shall be applied separately, from the exterior, to each member incorporating a locking device, in a direction parallel to the plane of the glass that would tend to open the window, while, simultaneously, an additional concentrated load (L2) is applied to the center of the exposed interlocking stile or rail, in the direction perpendicular to the plane of the glazing material toward the exterior side of the window. For interior sliding sash where the locking device is mounted at the interlocking stile or rail, the load attachment point shall be at the center of the member directly opposite the member which contains the locking device. Where more than one primary lock is used, the loads shall be equally divided

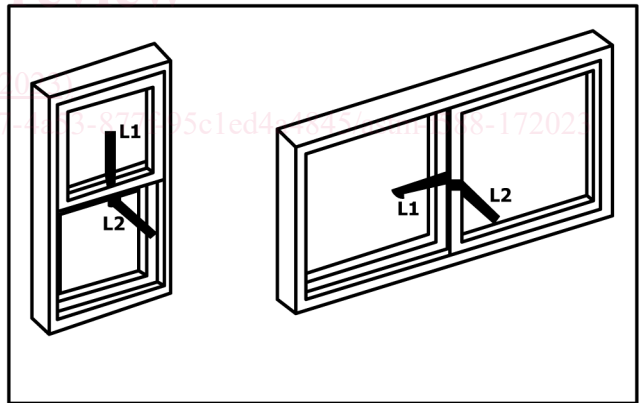

FIG. A2.4 Test A2—Exterior Sash

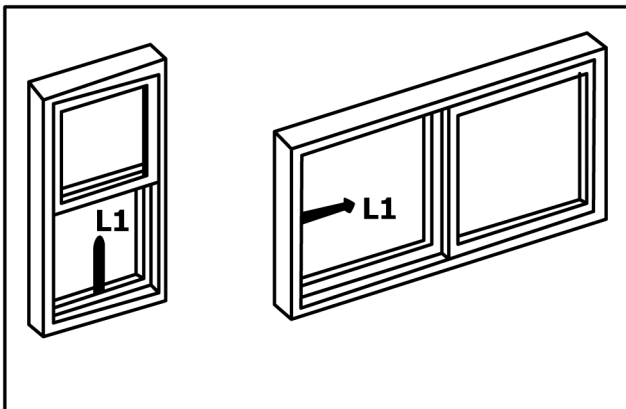

FIG. A2.1 Test A1—Interior Sash

among the locks and shall be applied simultaneously. (See Figs. A2.5 and A2.6.)

A2.6.5 *Test A4*—With the sliding sash in the test position, a concentrated load (L1) shall be applied separately, from the exterior, to each member incorporating a locking device, in a direction parallel to the plane of the glass that would tend to open the window, while, simultaneously, an additional concentrated load (L2) is applied to the center of the member opposite the interlocking stile or rail in the direction perpendicular to the plane of the glazing material toward the

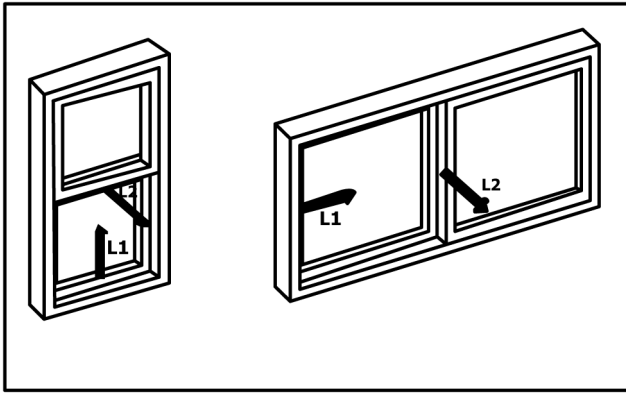

FIG. A2.5 Test A3—Interior Sash

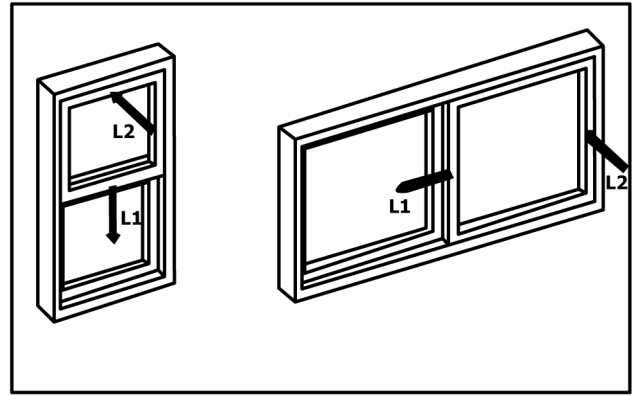

FIG. A2.8 Test A4—Exterior Sash

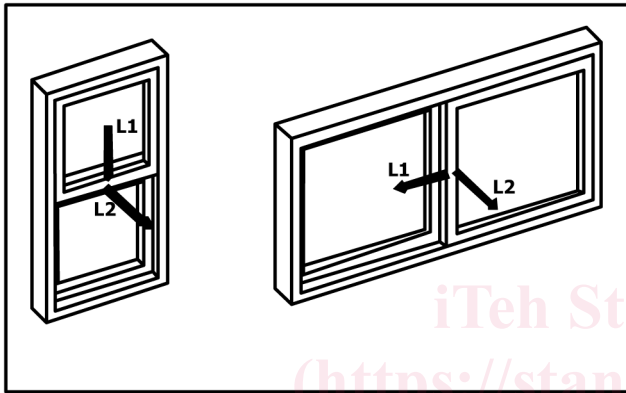

FIG. A2.6 Test A3—Exterior Sash

would tend to open the window, while, simultaneously an additional concentrated load (L2) is applied to the center of the member opposite the interlocking stile or rail in the direction perpendicular to the plane of the glazing material toward the exterior side of the window. For interior sliding sash where the locking device is mounted at the interlocking stile or rail, the load attachment point shall be at the center of the member directly opposite the member which contains the locking device. Where more than one primary lock is used, the loads shall be equally divided among the locks and shall be applied simultaneously. (See Figs. A2.9 and A2.10.)

A2.6.7 *Test A6, Outside Sliding Sash*—With the sliding sash lifted upward (for horizontal operating units) or shifted toward the frame jamb (for vertical operating units) to the full limit within the frame, a concentrated load (L1) shall be applied separately, from the exterior, to each member incorporating a locking device, at a point on the sash member within 3 in. (75 mm) of the locking device, in a direction parallel to the plane of the glass that would tend to open the window, while, simultaneously, an additional concentrated load (L2) is applied to the center of the exposed interlocking stile or rail in the direction perpendicular to the plane of the glazing material toward the interior side of the window, and while simultaneously applying a concentrated load (L3) outward within 3 in. (75 mm) of the corner of the operating sash on the interlocking stile or rail. For interior sliding sash where the locking device is mounted at the interlocking stile or rail, the load attachment

interior side of the window. For interior sliding sash where the locking device is mounted at the interlocking stile or rail, the load attachment point shall be at the center of the member directly opposite the member which contains the locking device. Where more than one primary lock is used, the loads shall be equally divided among the locks and shall be applied simultaneously. (See Figs. A2.7 and A2.8.)

A2.6.6 *Test A5*—With the sliding sash in the test position, a concentrated load (L1) shall be applied separately, from the exterior, to each member incorporating a locking device, at a point on the sash member within 3 in. (75 mm) of the locking device, in a direction parallel to the plane of the glass that

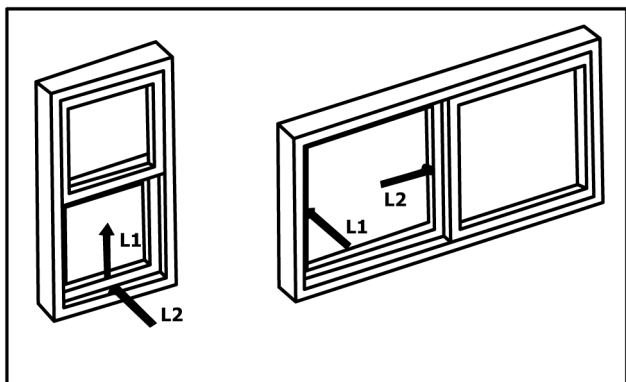

FIG. A2.7 Test A4—Interior Sash

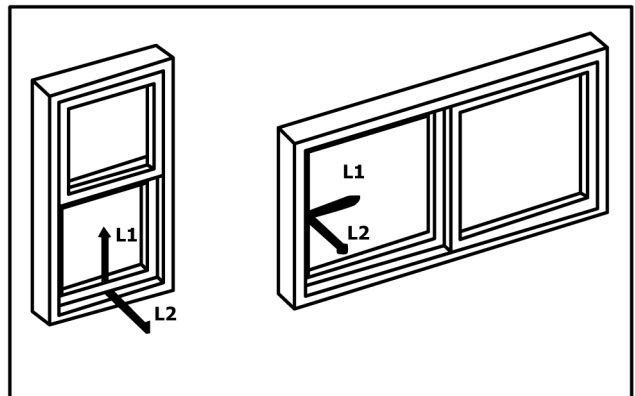

FIG. A2.9 Test A5—Interior Sash