



Designation: ~~D5452~~ – 20 D5452 – 23



Designation: ~~423/97423/10~~

## Standard Test Method for Particulate Contamination in Aviation Fuels by Laboratory Filtration<sup>1,2</sup>

This standard is issued under the fixed designation D5452; the number immediately following the designation indicates the year of original adoption or, in the case of revision, the year of last revision. A number in parentheses indicates the year of last reapproval. A superscript epsilon ( $\epsilon$ ) indicates an editorial change since the last revision or reapproval.

*This standard has been approved for use by agencies of the U.S. Department of Defense.*

### 1. Scope\*

1.1 This test method covers the gravimetric determination by filtration of particulate contaminant in a sample of aviation turbine fuel delivered to a laboratory.

1.1.1 The sample is filtered through a test membrane and a control membrane using vacuum. The mass change difference identifies the contaminant level per unit volume.

1.2 The values stated in SI units are to be regarded as the standard. The values given in parentheses are for information only.

1.3 *This standard does not purport to address all of the safety concerns, if any, associated with its use. It is the responsibility of the user of this standard to establish appropriate safety, health, and environmental practices and determine the applicability of regulatory limitations prior to use.* For specific hazard statements, see 4.2, 7.3, 7.5, 11.2, and X1.7.2. Before using this standard, refer to supplier's safety labels, material safety data sheets, and technical literature.

1.4 *This international standard was developed in accordance with internationally recognized principles on standardization established in the Decision on Principles for the Development of International Standards, Guides and Recommendations issued by the World Trade Organization Technical Barriers to Trade (TBT) Committee.*

### 2. Referenced Documents

#### 2.1 ASTM Standards:<sup>3</sup>

D56 Test Method for Flash Point by Tag Closed Cup Tester

D93 Test Methods for Flash Point by Pensky-Martens Closed Cup Tester

D1193 Specification for Reagent Water

D1535 Practice for Specifying Color by the Munsell System

D2244 Practice for Calculation of Color Tolerances and Color Differences from Instrumentally Measured Color Coordinates

<sup>1</sup> This test method is under the jurisdiction of ASTM International Committee D02 on Petroleum Products, Liquid Fuels, and Lubricants and is the direct responsibility of ASTM Subcommittee D02.J0.05 on Fuel Cleanliness. The technically equivalent standard as referenced is under the jurisdiction of the Energy Institute Subcommittee SC-B-11.

Current edition approved Sept. 1, 2020/May 1, 2023. Published October 2020/May 2023. Originally approved in 1993. Last previous edition approved in 2012/2020 as ~~D5452-12~~D5452 – 20. DOI: 10.1520/D5452-20.10.1520/D5452-23.

This test method has been separated from D2276 and has been modified primarily to establish improved safety measures.

<sup>2</sup> This test method has been developed through the cooperative effort between ASTM and the Energy Institute, London. ASTM and IP standards were approved by ASTM and EI technical committees as being technically equivalent but that does not imply both standards are identical.

<sup>3</sup> For referenced ASTM standards, visit the ASTM website, www.astm.org, or contact ASTM Customer Service at service@astm.org. For *Annual Book of ASTM Standards* volume information, refer to the standard's Document Summary page on the ASTM website.

\*A Summary of Changes section appears at the end of this standard

- D2276 Test Method for Particulate Contaminant in Aviation Fuel by Line Sampling
- D3828 Test Methods for Flash Point by Small Scale Closed Cup Tester
- D4306 Practice for Aviation Fuel Sample Containers for Tests Affected by Trace Contamination
- D4865 Guide for Generation and Dissipation of Static Electricity in Petroleum Fuel Systems
- D6615 Specification for Jet B Wide-Cut Aviation Turbine Fuel
- D8194 Practice for Evaluation of Suitability of 37 mm Filter Monitors and 47 mm Filters Used to Determine Particulate Contaminant in Aviation Turbine Fuels

### 3. Terminology

#### 3.1 Definitions:

3.1.1 *bond*, *v*—to connect two parts of a system electrically by means of a bonding wire to eliminate voltage differences.

3.1.2 *ground*, *vt*—to connect electrically with ground (earth).

3.1.3 *membrane filter*, *n*—a porous article of closely controlled pore size through which a liquid is passed to separate matter in suspension.

##### 3.1.3.1 Discussion—

Research Report RR:D02-1012<sup>4</sup> contains information on membrane filters that have historically met the requirements of the method and are still considered suitable. Practice D8194 contains the test methods and acceptance criteria for suitable membrane filters.

3.1.4 *particulate*, *adj*—of or relating to minute separate particles.

##### 3.1.4.1 Discussion—

Solids generally composed of oxides, silicates, and fuel insoluble salts.

3.1.5 *volatile fuels*, *n*—relatively wide boiling range volatile distillate.

##### 3.1.5.1 Discussion—

These are identified as Jet B in Specification D6615 or the military grade known as JP-4. Any fuel or mixture having a flash point less than 38 °C is considered to be volatile.

### 4. Summary of Test Method

4.1 A known volume of fuel is filtered through a pre-weighed test membrane filter and the increase in membrane filter mass is weight determined after washing and drying. The change in weight of a control membrane located immediately below the test membrane filter is also determined. The objective of using a control membrane is to assess whether the fuel itself influences the weight of a membrane. The particulate contaminant is determined from the increase in mass of the test membrane relative to the control membrane filter.

4.2 In order to ensure safety in handling, the test method requires that volatile fuels be transferred from the sample container to the funnel without pouring using a support stand shown in Fig. 1. Fuels having a verified flash point greater than 38 °C (refer to Test Method D56 or Test Methods D93 or D3828) may be transferred by pouring the sample from the sample container directly into the funnel. Bonding of a metallic sample container to the funnel is required. (**Warning**—Volatile fuels such as JP-4 and Jet B or mixtures having flash points below 38 °C have been ignited by electrostatic discharges when poured through membrane filters.)

4.3 Appendix X2 describes safety precautions to avoid static discharge in filtering fuel through membranes.

### 5. Significance and Use

5.1 This test method provides a gravimetric measurement of the particulate matter present in a sample of aviation turbine fuel delivered to a laboratory for evaluation. The objective is to minimize these contaminants to avoid filter plugging and other

<sup>4</sup> Supporting data (including a list of suppliers who have provided data indicating their membranes, field monitors, and field monitor castings) have been filed at ASTM International Headquarters and may be obtained by requesting Research Report RR:D02-1012. Contact ASTM Customer Service at [service@astm.org](mailto:service@astm.org).

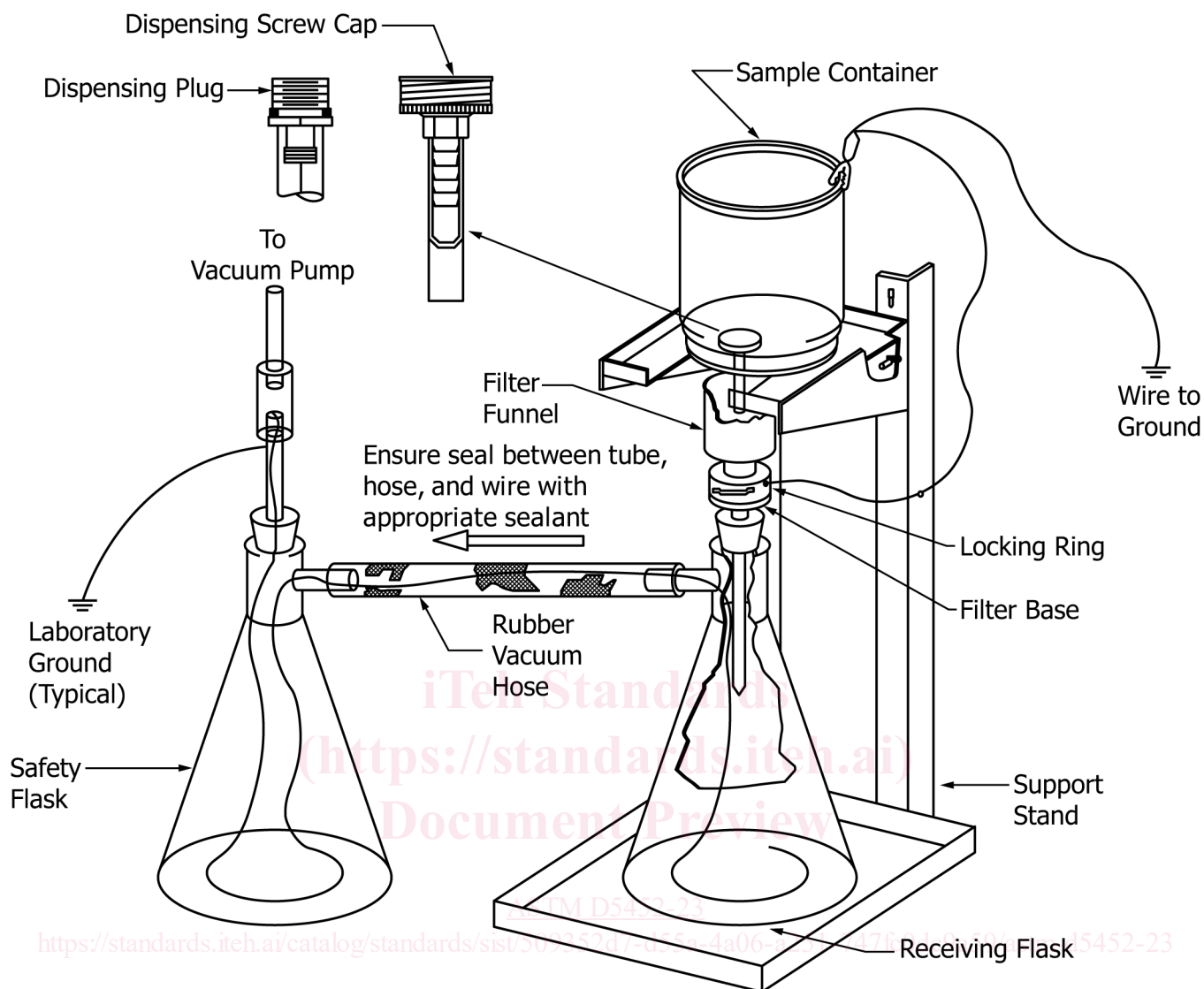

FIG. 1 Apparatus for Determining Total Contaminant

operational problems. Although tolerable levels of particulate contaminants have not yet been established for all points in fuel distribution systems, the total contaminant measurement is normally of most interest.

## 6. Apparatus

6.1 *Analytical Balance*, single- or double-pan, the precision standard deviation of which must be 0.07 mg or better.

6.2 *Oven*, of the static type (without fan-assisted air circulation), controlling to  $90\text{ }^{\circ}\text{C} \pm 5\text{ }^{\circ}\text{C}$ .

6.3 *Petri Dishes*, approximately 125 mm in diameter with removable glass supports for membrane filters.

6.4 *Forceps*, flat-bladed with unserrated, non-pointed tips.

6.5 *Vacuum System*.

6.6 *Test Membrane Filters*,<sup>4,5</sup> plain, 47 mm diameter, nominal pore size 0.8 μm (see **Note 1**).

6.7 *Control Membrane Filters*,<sup>4,5</sup> 47 mm diameter, nominal pore size 0.8 μm. (Gridded control membrane filters may be used for purpose of identification.)

NOTE 1—Matched weight membrane filters,<sup>5</sup> 47 mm diameter, nominal pore size 0.8 μm, may be used as test and control membrane filters if so desired. Use of matched-weight membrane filters precludes the necessity for carrying out subsequently the procedures detailed in Section 10.

6.8 *Dispenser for Filtered Flushing Fluid*, 0.45 μm membrane filters to be provided in the delivery line (see **Fig. 2**). Alternatively, flushing fluid that has been pre-filtered through a 0.45 μm membrane before delivery to the dispenser flask is acceptable.

6.9 *Air Ionizer*, for the balance case. See **Note 2** and **Note 3**.

NOTE 2—When using a solid-pan balance, the air ionizer may be omitted provided that, when weighing a membrane filter, it is placed on the pan so that no part protrudes over the edge of the pan.

NOTE 3—Air ionizers should be replaced within 1 year of manufacture.

6.10 *Filtration Apparatus*, of the type shown in **Fig. 1**. It consists of a filter funnel and a funnel base with a filter support such that a membrane filter can be gripped between the sealing surface and the base by means of a locking ring. Use a metal funnel with at least a 70 mm diameter at the top.

6.11 *Support Stand*, (required when the sample flash point is lower than 38 °C) as shown in **Fig. X3.1**, having adjustable height, integral spill collection pan at the base, and an edge on the can shelf to prevent the can from slipping off. The shelf is slotted. Refer to **Fig. X3.1** for fabrication details.

6.12 *Dispensing Cap or Plug*, (required when the sample flash point is lower than 38 °C) with approximately 9.5 mm inside diameter hose barb 32 mm long on which a 75 mm to 100 mm long piece of fuel resistant, flexible, plastic tubing is installed (see

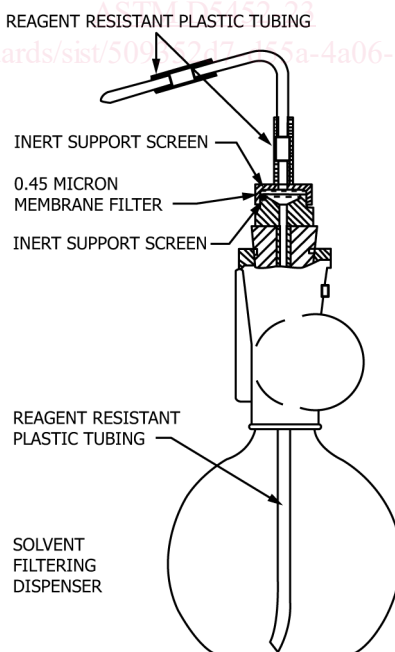

**FIG. 2 Apparatus for Filtering and Dispensing Flushing Fluid**

<sup>5</sup> All available membrane filters are not suitable for this application. Apparatus considered for this application shall be checked by the user for suitability in accordance with the requirements of RR:D02-1012, 1994 revision.

**Fig. 1.** The plug is for sample containers having  $\frac{3}{4}$  in. (19 mm) female pipe threads while the cap is for containers having 1.75 in. (44 mm) diameter sheet metal threads. Dispensing spouts for other containers must be fabricated. The closure gasket shall be made of a fuel resistant material. A paper composition material is not acceptable.

6.13 *Sample Container*, should be a 3.8 L to 5 L (1 gal) epoxy lined sample can, preferably the same container in which the sample was collected and should conform to the criteria set forth in Practice **D4306**. When samples are collected in a smaller container than recommended here, select a container that does not trap particles when the contents are poured out.

6.14 *Receiving Flask*, shall be glass or metal. A graduated glass flask is preferred so that the space remaining for fuel can be observed. The filtration apparatus is fitted to the top of the flask. The flask shall be fitted with a side arm to connect the vacuum system. The flask should be large enough to contain the sample and flushing fluids.

6.15 *Safety Flask*, shall be glass containing a sidearm attached to the receiving flask with a fuel and solvent resistant rubber hose and shall be connected to the vacuum system.

6.16 *Ground/Bond Wire*, #10–#19 (0.912 mm to 2.59 mm) bare stranded flexible, stainless steel or copper installed in the flasks and grounded as shown in **Fig. 1**. If a metallic flask(s) is used instead of glass, the flask(s) must be grounded.

6.17 *Plastic Film*, polyethylene or any other clear film not adversely affected by flushing fluids. Refer to **Appendix X4**.

6.18 *Multimeter/VOM*, used for determining whether electrical continuity is 10 ohms or less between 2 points.

## 7. Reagents

7.1 *Purity of Reagents*—Reagent grade chemicals shall be used in all tests. Unless otherwise indicated, it is intended that all reagents shall conform to the specifications of the Committee on Analytical Reagents of the American Chemical Society, where such specifications are available.<sup>6</sup> Other grades may be used, provided it is first ascertained that the reagent is of sufficiently high purity to permit its use without lessening the accuracy of the determination.

7.2 *Purity of Water*—Unless otherwise indicated references to water shall be understood to mean reagent water as defined by Type III of Specification **D1193**.

7.3 *Isopropyl Alcohol*, (**Warning**—Flammable.)  
<https://standards.iteh.ai/catalog/standards/sist/509352d7-d55a-4a06-a251-747fc0dc9a59/astm-d5452-23>

7.4 *Liquid Detergent*, water-soluble.

7.5 *Flushing Fluids*—Petroleum spirit (also known as petroleum ether or IP Petroleum Spirit 40/60), having boiling range from 35 °C to 60 °C. (**Warning**—Extremely flammable. Harmful if inhaled. Vapors are easily ignited by electrostatic discharges, causing flash fire. See **Appendix X2**.)

7.6 *Filtered Flushing Fluids*—Filtered fluids are fluids filtered through a nominal 0.45 μm membrane filter. Filtered flushing fluids are most conveniently obtained by means of the dispenser described in **Fig. 2**.

## 8. Sampling

8.1 All containers and their closures shall be thoroughly cleaned in accordance with Practice **D4306**.

8.2 To obtain a representative sample from a fuel stream and to avoid external contamination, the sample may be drawn from the flushing fitting of a field sampling kit (see Test Method **D2276**). Ensure that the line is first flushed with the fuel to be sampled and that the line is externally clean.

<sup>6</sup> *ACS Reagent Chemicals, Specifications and Procedures for Reagents and Standard-Grade Reference Materials*, American Chemical Society, Washington, DC. For suggestions on the testing of reagents not listed by the American Chemical Society, see *Analar Standards for Laboratory Chemicals*, BDH Ltd., Poole, Dorset, U.K., and the *United States Pharmacopeia and National Formulary*, U.S. Pharmacopeial Convention, Inc. (USPC), Rockville, MD.

8.3 Whether or not a sampling kit is available, suitable precautions shall be taken to avoid sample contamination by the use of a suitable sampling point in accordance with Test Method [D2276](#). If the quick-disconnect sampling connection is not used, a stainless steel ball or plug type valve should be selected as its internal design avoids the possibility of trapping or generating solid contaminant. Samples that are collected for general laboratory or chemical analysis are not necessarily suitable for this test method because insufficient care may have been taken to avoid particulate contamination.

8.4 Where possible a 3.8 L to 5 L (1 gal) fuel sample should be taken, preferably in the same container that will be used in the test to avoid the need to transfer from one container to another with increased possibility of contamination. Ideally, a sample to be tested should be collected in a single container and transferred to the laboratory for testing. If the sample is collected in small containers such as glass bottles and then shipped to the laboratory, the collection containers shall be handled in a way to flush particulates into the transport container which should be UN/ICAO approved for public transport. Results obtained by taking other sample volumes can have different precisions.

8.5 The sample volume shall be quoted with the results. If the sample was transferred from one container to another before the test was performed, this shall also be noted with the test results.

## **9. Preparation of Apparatus and Sample Containers**

9.1 Clean all components of the filtration apparatus, including the funnels, filter base, forceps, petri dishes, dispensing cap or plug and tubing (from [6.12](#)) as described in [9.1.2 – 9.1.6](#).

9.1.1 Remove any labels, tags, and so forth.

9.1.2 Wash with warm tap water containing detergent.

9.1.3 Rinse thoroughly with warm tap water.

9.1.4 Rinse thoroughly with reagent water. Container caps should be handled only externally with clean laboratory crucible tongs during this and subsequent washing.

9.1.5 Rinse thoroughly with filtered isopropyl alcohol.

9.1.6 Rinse thoroughly with filtered flushing fluid.

9.1.7 For special cleanliness procedures in facilities that can have airborne dust, see [Appendix X4](#).

## **10. Preparation of Test and Control Membrane Filters**

10.1 Two 47 mm membrane filters of nominal pore size 0.8  $\mu\text{m}$  are required: a test and a control membrane filter. Matched-weight membrane filters may be used if so desired (see [Note 1](#)). If matched-weight membrane filters are used, it is unnecessary to carry out the procedures detailed in this section because they had been carried out previously by the membrane filter supplier. The two membrane filters used for each individual test should be identified by marking the petri dishes used as containers. Clean glassware used in preparation of membrane filters must be cleaned as described in [9.1](#). Refer to [Appendix X4](#).

10.1.1 Using forceps, place the test and control membrane filters side by side in a clean petri dish. To facilitate handling, the membrane filters should rest on clean glass support rods in the petri dish.

10.1.2 Place the petri dish with its lid slightly ajar, in an oven at  $90\text{ }^{\circ}\text{C} \pm 5\text{ }^{\circ}\text{C}$  and leave it for 30 min.

10.1.3 Remove the petri dish from the oven and place it near the balance. The petri dish cover should be ajar but still protecting the membrane filters from contamination from the atmosphere. Allow 30 min for the membrane filters to come to equilibrium with the ambient air temperature and humidity.

10.1.4 Remove the control membrane filter from the petri dish with forceps, handling by the edge only, and place it centrally on the weighing pan. Weigh it and return it to the petri dish.

10.1.5 Repeat [10.1.4](#) for the test membrane filter. Record the membrane filter masses.

## 11. Procedure

11.1 *Prepare the Filter Funnel and Filter Base Assembly*—Using clean forceps, place the two test membrane filters centrally on the membrane filter support ring of the filtration apparatus (see Fig. 1) with the test membrane on top of the control membrane. Install the filter funnel. If using matched weight membranes, either one can be on top. With the membrane filter in place, perform a continuity test using a multimeter between the filter funnel and the filter holder. The meter shall read 10  $\Omega$  or less.

11.2 *Prepare the Sample Container for the Filtration Test:*

11.2.1 ~~Thoroughly clean the outside of~~ Visually inspect the sample container. If soiled, ensure the sample container ~~is properly sealed then thoroughly clean~~ the region of the closure by washing with detergent in water and rinsing with tap water and filtered isopropyl alcohol. ~~If the sample container is not visibly soiled, wipe the outside of the sample container in the region of the closure with a paper towel damp with tap water or filtered isopropyl alcohol.~~ Remove all labels from the container top. Shake the container vigorously for about ½ min to flush particles from internal surfaces of the installed plug or cap into the fuel in the container. Remove the closure. If it is a cap, remove any external contaminant that may be present in the threads on the sample container by washing with filtered flushing fluid, ensuring that none of the washings enter the container.

NOTE 4—If the closure is a plug, preserve it in a clean petri dish for flushing at 11.2.5 or at 11.4.9. If it is a cap, it will not be flushed at 11.4.9, because its internal threads can be contaminated with external dirt.

11.2.2 If it has been determined that the fuel sample has a verified flash point greater than 38 °C and that the sample is therefore to be poured into the filter funnel rather than to use the support stand, connect the receiving flask and safety flask with hose and connect the grounding cable assembly as shown in Fig. 1. Place the pre-assembled filter funnel and filter base assembly on the receiving flask. This filtration procedure will definitely result in electrostatic charges that shall be grounded for safety. Refer to Appendix X2.

11.2.3 Commence pouring the sample into the filter funnel and switch on the vacuum source. Move (swirl) the sample container about in order to carry particles into the funnel.

11.2.4 After the fuel has filtered completely, disconnect the vacuum, and record the volume of the filtered sample.

11.2.5 If the sample had been transferred from other containers, rinse them with four 50 mL quantities of filtered flushing fluid directly into the filter funnel. The external threads of the sample container plug may now be rinsed with 30 mL of filtered flushing fluid directly into the filter funnel. Then, proceed to 11.4.10.

11.3 If it was determined that the support stand should be used for filtering the fuel sample, prepare the apparatus.

NOTE 5—All of this apparatus should be mounted in an exhaust hood to minimize operator exposure to fumes.

11.3.1 Connect the receiving flask and safety flask with hose, and connect the grounding cable assembly as shown in Fig. 1. Place the pre-assembled filter funnel and filter base assembly on the receiving flask. Ensure the adjustable shelf is located approximately 25 mm to 50 mm above the top of the filter funnel. This filtration procedure will definitely result in electrostatic charges that must be grounded for safety. Refer to Appendix X2.

11.3.2 Secure a ground clip and wire to the container support and ground in series as shown in Fig. 1.

11.3.3 Screw the dispensing closure from 6.12 firmly on the sample container. Slip a length of plastic tubing mentioned in 6.12 snugly over the hose barb of the above (dispensing plug or cap). If the closure will not fit the original sample container, shake the original sample container briefly, and quickly transfer the sample, by use of a funnel, to another container that can be equipped with a dispensing cap or plug. Ensure that the new container has been rinsed as described in Section 9. Preserve at a clean location the now empty original container pending flushing at 11.4.8.

11.4 *Transfer the Fuel in the Sample Container to the Filter Funnel:*

11.4.1 The length of the tubing on the dispensing plug or cap should be sufficient such that when the sample container is resting on the shelf, the tubing will extend well into the filter funnel, approximately halfway down to where the cone transition is located.