



Designation: ~~D5977—15~~ D5977 – 23

Standard Specification for High Load Rotational Spherical Bearings for Bridges and Structures¹

This standard is issued under the fixed designation D5977; the number immediately following the designation indicates the year of original adoption or, in the case of revision, the year of last revision. A number in parentheses indicates the year of last reappraisal. A superscript epsilon (ϵ) indicates an editorial change since the last revision or reappraisal.

1. Scope

1.1 This specification covers bridge bearings that consist of a spherical rotational element, where a stainless steel convex surface slides against a concave carbon steel plate covered with woven or sheet polytetrafluoroethylene (PTFE). The function of the bearing is to transfer loads and to accommodate any relative movement, including rotation between a bridge superstructure and its supporting structure, or both.

1.2 This specification covers the requirements of spherical bearings with a standard horizontal load (a maximum of 10 % of vertical).

1.3 The requirements stated in this specification are the minima necessary for the manufacture of quality bearing devices. It may be necessary to increase these minimum values due to other design conditions.

1.4 Units—The values stated in inch-pound units are to be regarded as the standard. The values given in parentheses are for information only. ~~mathematical conversions to SI units that are provided for information only and are not considered standard.~~

1.5 The text of this standard references notes and footnotes which provide explanatory material. These notes and footnotes (excluding those in tables and figures) shall not be considered as requirements of the standard.

1.6 The following safety hazards caveat pertains only to the test method portion, Section 7, of this specification: *This standard does not purport to address all of the safety concerns, if any, associated with its use. It is the responsibility of the user of this standard to establish appropriate safety and health, safety, health, and environmental practices and determine the applicability of regulatory limitations prior to use.*

1.7 This international standard was developed in accordance with internationally recognized principles on standardization established in the Decision on Principles for the Development of International Standards, Guides and Recommendations issued by the World Trade Organization Technical Barriers to Trade (TBT) Committee.

2. Referenced Documents

2.1 *ASTM Standards*:²

A36/A36M Specification for Carbon Structural Steel

¹ This specification is under the jurisdiction of ASTM Committee D04 on Road and Paving Materials and is the direct responsibility of Subcommittee D04.32 on Bridges and Structures.

Current edition approved June 1, 2015May 1, 2023. Published July 2015May 2023. Originally approved in 1996. Last previous edition approved in 20122015 as D5977—03 (2012)D5977 – 15. DOI: 10.1520/D5977-15.10.1520/D5977-23.

² For referenced ASTM standards, visit the ASTM website, www.astm.org, or contact ASTM Customer Service at service@astm.org. For *Annual Book of ASTM Standards* volume information, refer to the standard's Document Summary page on the ASTM website.

- [A167](#) Specification for Stainless and Heat-Resisting Chromium-Nickel Steel Plate, Sheet, and Strip (Withdrawn 2014)³
- [A240/A240M](#) Specification for Chromium and Chromium-Nickel Stainless Steel Plate, Sheet, and Strip for Pressure Vessels and for General Applications
- [A304](#) Specification for Carbon and Alloy Steel Bars Subject to End-Quench Hardenability Requirements
- [A572/A572M](#) Specification for High-Strength Low-Alloy Columbium-Vanadium Structural Steel
- [A588/A588M](#) Specification for High-Strength Low-Alloy Structural Steel, up to 50 ksi [345 MPa] Minimum Yield Point, with Atmospheric Corrosion Resistance
- [A709/A709M](#) Specification for Structural Steel for Bridges
- [D638](#) Test Method for Tensile Properties of Plastics
- [D792](#) Test Methods for Density and Specific Gravity (Relative Density) of Plastics by Displacement
- [D1457](#) Specification for Polytetrafluoroethylene (PTFE) Molding and Extrusion Materials (Withdrawn 1996)³
- [D1777](#) Test Method for Thickness of Textile Materials
- ~~D2256~~[D2256/D2256M](#) Test Method for Tensile Properties of Yarns by the Single-Strand Method
- 2.2 *AASHTO Standard*:⁴
- [AASHTO Standard Specifications for Highway Bridges](#)
- 2.3 *AWS Standards*:⁵
- ~~C-2.2-67~~[C2.2-67](#) Metalizing with Aluminum and Zinc for Protection of Iron and Steel
- ~~D-1.5~~[D1.5](#) ANSI/AASHTO/AWS Bridge Welding Code

3. Classification

3.1 The bearings are furnished in three types, as follows:

- 3.1.1 *Fixed Spherical Bearing*—Rotation only.
- 3.1.2 ~~Uni-Directional~~[Unidirectional Sliding Spherical Bearing](#)—Rotation plus movement in one direction.
- 3.1.3 *Multi-Directional Sliding Spherical Bearing*—Rotation plus movement in all directions.

4. Material Specifications

4.1 *Steel*—The steel used for all major plates shall be structural steel conforming to ~~Specifications~~[Specification A36/A36M, A588/A588M, A572/A572M, or A709/A709M](#), as required. All exposed surfaces shall be zinc metalized according to ~~AWS C-2.2-67~~[C2.2-67](#) (with no chipping), having a minimum thickness of ~~6 mil~~[6 mil \(0.152 mm\)](#) or treated with other project-approved coating systems such as coal tar or inorganic zinc paint. The dry film thickness (DFT) of the approved paint system must be specified by the owner.

4.2 *Stainless Steel*:

4.2.1 *Flat Sliding Surface*—The sheet stainless steel used as the mating sliding surface to the woven fabric PTFE or sheet PTFE in the sliding spherical bearings shall conform to [Specification A167 or A240/A240M](#), type 304, ~~20 μin. (0.5 μm)~~[20 μin. \(0.5 μm\)](#) rms finish.

4.2.2 *Convex Surface*—The solid stainless steel plate or sheet stainless steel used as the mating rotational convex surface to the woven fabric PTFE or sheet PTFE shall conform to [Specification A167 or A240/A240M](#), type 304. The surface shall be machined to a surface finish of ~~20 μin. (0.5 μm)~~[20 μin. \(0.5 μm\)](#) rms or less.

4.3 *Woven Fabric Polytetrafluoroethylene (PTFE)*—The woven fabric PTFE shall be made from virgin PTFE oriented multifilament fibers with or without a high-strength backing.

4.3.1 The thickness of the woven fabric PTFE in the free state shall be a minimum of $\frac{3}{32}$ in. (2.38 mm) when measured in accordance with [Test Method D1777](#).

³ The last approved version of this historical standard is referenced on www.astm.org.

⁴ Available from American Association of State Highway and Transportation Officials (AASHTO), 444 N. Capitol St., NW, Suite 249, Washington, DC 20001, <http://www.transportation.org>.

⁵ Available from American Welding Society (AWS), 550 NW LeJeune Rd., Miami, FL 33126, <http://www.aws.org>.

4.3.2 The thickness of the bonded woven fabric PTFE under the application of vertical load (excluding any backing material) shall be a minimum of the following:

- (1) 1/16 in. (1.59 mm) from 0 psi (0 N/mm²) to 3500 psi (24.1 N/mm²).
- (2) 3/64 in. (1.19 mm) from 3501 psi (24.1 N/mm²) to 4500 psi (31.0 N/mm²).

4.3.3 The woven fabric PTFE shall be mechanically interlocked and epoxy-bonded to the substrate using a system that prevents migration of the epoxy through the fabric. The use of a mechanical interlock system along with the epoxy increases the bond strength, providing a redundancy for the prevention of migration of the PTFE material. Any edges, other than the selvage (woven edge), shall be oversewn so that no cut fabric edges are exposed.

4.3.4 The individual PTFE filaments used in making the woven PTFE fabric shall conform to the physical requirements of **Table 1**.

4.4 *Sheet Polytetrafluoroethylene (PTFE)*—The sheet PTFE shall be virgin material (not reprocessed) meeting the requirements of Specification **D1457**. The PTFE shall be resistant to acids, alkalis, petroleum products, and nonabsorption of water. It shall be stable for temperatures up to 500°F (260°C) 500 °F (260 °C) and shall be nonflammable. When used in PTFE surfaces used for guide bars only, filler material shall be composed of milled glass fibers or carbon.

4.4.1 The thickness of the sheet PTFE shall be a minimum of 1/8 in. (3.17 mm) and shall be recessed at least ~~one-half~~ one half of its thickness.

4.4.2 The PTFE for the principal slide surface and for guide bars shall conform to the physical requirements listed in **Table 2**.

TABLE 2 Physical Property Requirements for Sheet PTFE^A

Physical Properties	Test Method	Requirement
Ultimate tensile strength, min, psi (MPa)	D638	2800 (19.3)
Ultimate elongation, min, %	D638	200
Specific gravity, min	D792	2.12

^A 15 % glass-filled PTFE may be used for guide bar surfaces (Specification **D1457**).

5. Design Requirements

ASTM D5977-23

<https://standards.iteh.ai/catalog/standards/sist/da34ab6a-2356-492e-b58c-92eb08be4601/astm-d5977-23>

NOTE 1—*To Designer:* The bearing details shall be designed in accordance with the requirements of the current edition with interims of the AASHTO Standard Specifications for Highway Bridges or other governing design procedures.

5.1 *Rotational Elements:*

5.1.1 The spherical radius shall be determined such that the resulting geometry of the bearing is capable of withstanding the greatest ratio of the horizontal load to vertical load under all loading conditions to prevent the unseating (separation at the edges) of the convex/concave elements.

5.1.2 Unseating of the curved spherical surfaces relative to each other shall be prevented by transferring horizontal forces through specifically designed restraints or by control of the spherical radius.

5.1.3 Acceptable spherical radius control shall be given when the configuration of the woven fabric PTFE concave radius follows the following design:

TABLE 1 Physical Property Requirements for Woven PTFE

Physical Properties	Test Method	Requirement
Ultimate tensile strength, min, psi (MPa)	D2256	24 000 (165.4)
Ultimate elongation, min, %	D2256	>10 % ≤ 35 %

TABLE 1 Physical Property Requirements for Woven PTFE

Physical Properties	Test Method	Requirement
Ultimate tensile strength, min, psi (MPa)	D2256/D2256M	24 000 (165.4)
Ultimate elongation, min, %	D2256/D2256M	>10 % ≤ 35 %

$$\text{ratio} \leq \tan \alpha \tag{1}$$

where:

~~ratio = worst-case ratio of horizontal to vertical loads.~~

ratio = worst-case ratio of horizontal to vertical loads.

$$\alpha = \left(\arcsin \left(\frac{d/2}{R_{\max}} \right) \right) - (\text{design rotation}) \tag{2}$$

where:

d = projected diameter of the woven fabric PTFE,

design rotation = design rotation of the bearing (in degrees), and

R_{\max} = maximum allowable radius to prevent uplift within the bearing during the worst horizontal to vertical load case.

5.1.4 Calculations showing determination of the radius shall be submitted for approval.

5.1.5 The radius of the convex plate shall be less than the radius calculated for the woven fabric PTFE (concave plate) by a value equal to the thickness of the PTFE.

5.1.6 The concave surface shall face down whenever the resulting center of rotation is not detrimental to the system geometry. See Fig. 1.

5.1.7 The minimum thickness at the center of the concave spherical element shall be 3/4 in. (19 mm).

5.1.8 The minimum thickness at the edge of the convex spherical element shall be 1/2 in. (12.7 mm).

5.1.9 Vertical and horizontal clearance between the rotating (attached to the superstructure) and non-rotating (attached to the substructure) spherical bearing components, including fasteners, shall be no less than 1/8 in. (3.17 mm) when rotated to 150 % of the design rotation.

NOTE 2—To Designer: The spherical PTFE pad may be damaged at 150 % of the design rotation.

5.1.10 The concave radius shall be machined to a tolerance of $-0.000, +0.010$ in. ($-0, +0.25$ of $-0.000, +0.010$ in. ($-0, +0.25$ mm)).

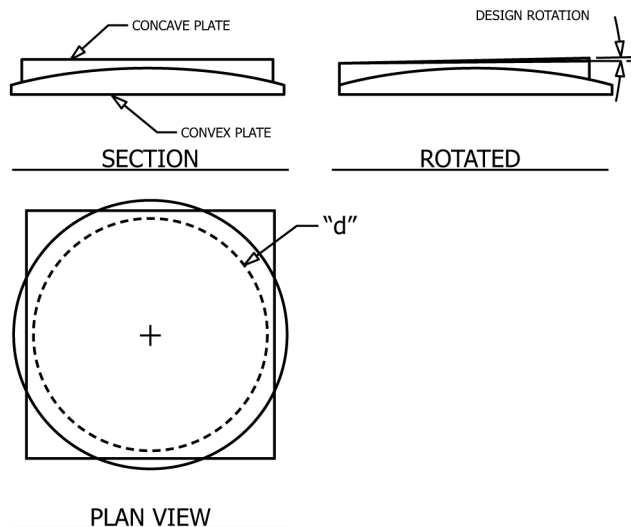

FIG. 1 Views of a Spherical Bearing

5.1.11 The convex radius shall be machined to a tolerance of $-0.010, +0.000$ in. ($-0.25, +0$ of $-0.010, +0.000$ in. ($-0.25, +0$ mm).

5.2 *Stainless Steel Sliding Surface:*

5.2.1 The thickness of the stainless steel sheet shall be 11 gage, with a manufacturer's minimum thickness of 0.059 in. (1.5 mm).

5.2.2 *Fixing of the Stainless Steel Sheet*—The stainless steel sheet shall be attached to its backing plate by continuous fillet welding along its edges. It is essential that the stainless steel sheet remain in contact with the base metal throughout its service life and that interface corrosion cannot occur. The attachment of the stainless steel to its back-up plate shall be capable of resisting the frictional force set up in the bearing. Welding must be in accordance with ANSI/AASHTO/AWS D1.5.

5.2.3 The backing plate shall extend beyond the edge of the stainless steel sheet to accommodate the weld; also, the weld must not protrude above the stainless steel sheet. TIG welding of the stainless steel sheet is highly recommended to achieve this connection.

5.2.4 The flat horizontal stainless steel sliding surface shall cover the PTFE surface completely in all operations, plus one additional ~~in~~ inch (25.4 mm) in all directions of movement. For a guided bearing with which there is no transverse movement, this requirement does not apply in the transverse direction.

5.3 *Woven Fabric PTFE Concave or Sliding Surfaces, or Both:*

5.3.1 The woven fabric PTFE shall be mechanically interlocked to the steel substrate. An epoxy bond system shall be used for additional security. After completion of the bonding operation, the PTFE surface shall be smooth and free from blisters, bubbles, and evidence that any epoxy has migrated through the woven fabric PTFE.

5.3.2 The area of the woven fabric PTFE shall be designed for a maximum average working stress of 4500 psi (31.0 ~~N/mm²~~ N/mm²).

5.3.3 The maximum edge pressure on the woven fabric PTFE shall not exceed 10 000 psi (68.8 N/mm²).

5.4 *Sheet PTFE on Concave or Sliding Surfaces, or Both:*

5.4.1 The sheet PTFE shall be pure virgin, unfilled, meeting the requirements of Specification **D1457**. The sheet PTFE shall be recessed to ~~one-half~~ one half of its thickness and epoxy bonded to the steel substrate. The PTFE surface shall be smooth and free from blisters or bubbles after completion of the bonding operation.

5.4.2 The area of the sheet PTFE shall be designed for a maximum average working stress of 3500 psi (24.1 N/mm²).

5.4.3 The maximum edge pressure on the sheet PTFE shall not exceed 5000 psi (34.4 N/mm²).

5.4.4 The surface of the PTFE sheet to be epoxy bonded shall be etched using the sodium naphthalene or sodium ammonia etching process.

5.5 *Sheet PTFE Guiding Surfaces:*

5.5.1 Attachment of the sheet PTFE to the steel substrate of the guiding surface shall be performed by epoxy bonding and mechanical fastening. The mechanical fastening shall consist of a minimum of two stainless steel screws (Specification **A304**) located on the centerline of the strip of PTFE and located $\frac{1}{2}$ in. (12.7 mm) from each end of the PTFE strip. The top of the screws shall be recessed a minimum of 50 % of the amount of protrusion of the PTFE above the steel substrate.

5.5.2 The surface of the PTFE sheet to be epoxy bonded shall be etched using the sodium naphthalene or sodium ammonia etching process.

5.6 *Guide Bars:*