



Designation: D5886 – 95 (Reapproved 2023)

Standard Guide for Selection of Test Methods to Determine Rate of Fluid Permeation Through Geomembranes for Specific Applications¹

This standard is issued under the fixed designation D5886; the number immediately following the designation indicates the year of original adoption or, in the case of revision, the year of last revision. A number in parentheses indicates the year of last reapproval. A superscript epsilon (ϵ) indicates an editorial change since the last revision or reapproval.

1. Scope

1.1 This guide covers selecting one or more appropriate test methods to assess the permeability of all candidate geomembranes for a proposed specific application to various permeants. The widely different uses of geomembranes as barriers to the transport and migration of different gases, vapors, and liquids under different service conditions require determinations of permeability by test methods that relate to and simulate the service. Geomembranes are nonporous, homogeneous materials that are permeable in varying degrees to gases, vapors, and liquids on a molecular scale in a three-step process by: (1) dissolution in or absorption by the geomembrane on the upstream side, (2) diffusion through the geomembrane, and (3) desorption on the downstream side of the barrier.

1.2 The rate of transmission of a given chemical species, whether as a single permeant or in mixtures, is driven by its chemical potential or in practical terms by its concentration gradient across the geomembrane. Various methods to assess the permeability of geomembranes to single component permeants, such as individual gases, vapors, and liquids are referenced and briefly described.

1.3 Various test methods for the measurement of permeation and transmission through geomembranes of individual species in complex mixtures such as waste liquids are discussed.

1.4 *This standard does not purport to address all of the safety concerns, if any, associated with its use. It is the responsibility of the user of this standard to establish appropriate safety, health, and environmental practices and determine the applicability of regulatory limitations prior to use.*

1.5 *This international standard was developed in accordance with internationally recognized principles on standardization established in the Decision on Principles for the Development of International Standards, Guides and Recommendations issued by the World Trade Organization Technical Barriers to Trade (TBT) Committee.*

¹ This guide is under the jurisdiction of ASTM Committee D35 on Geosynthetics and is the direct responsibility of Subcommittee D35.10 on Geomembranes.

Current edition approved May 1, 2023. Published May 2023. Originally approved in 1995. Last previous edition approved in 2018 as D5886 – 95 (2018). DOI: 10.1520/D5886-95R23.

2. Referenced Documents

2.1 ASTM Standards:²

- D471 Test Method for Rubber Property—Effect of Liquids
- D814 Test Method for Rubber Property—Vapor Transmission of Volatile Liquids
- D815 Test Method for Testing Coated Fabrics Hydrogen Permeance (Withdrawn 1987)³
- D1434 Test Method for Determining Gas Permeability Characteristics of Plastic Film and Sheeting
- D4439 Terminology for Geosynthetics
- D4491/D4491M Test Methods for Water Permeability of Geotextiles by Permittivity
- E96/E96M Test Methods for Gravimetric Determination of Water Vapor Transmission Rate of Materials
- F372 Test Method for Water Vapor Transmission Rate of Flexible Barrier Materials Using an Infrared Detection Technique (Withdrawn 2009)³
- F739 Test Method for Permeation of Liquids and Gases Through Protective Clothing Materials Under Conditions of Continuous Contact

3. Terminology

3.1 Definitions:

3.1.1 *downstream, n*—the space adjacent to the geomembrane through which the permeant is flowing.

3.1.2 *geomembrane, n*—an essentially impermeable geosynthetic composed of one or more synthetic sheets. (See Terminology D4439.)

3.1.2.1 *Discussion*—In geotechnical engineering, “essentially impermeable” means that no measurable liquid flows through a geosynthetic when tested in accordance with Test Methods D4491/D4491M.

² For referenced ASTM standards, visit the ASTM website, www.astm.org, or contact ASTM Customer Service at service@astm.org. For *Annual Book of ASTM Standards* volume information, refer to the standard’s Document Summary page on the ASTM website.

³ The last approved version of this historical standard is referenced on www.astm.org.

3.1.3 *geosynthetic, n*—a planar product manufactured from polymeric material used with soil, rock, earth, or other geotechnical engineering-related material as an integral part of a man-made project, structure, or system. (See Terminology D4439.)

3.1.4 *permeability, n*—the rate of flow under a differential pressure, temperature, or concentration of a gas, liquid, or vapor through a material. (Modified from Test Methods D4491/D4491M.)

3.1.5 *permeant, n*—a chemical species, gas, liquid, or vapor that can pass through a substance.

4. Summary of Guide

4.1 The wide range of uses of geomembranes as barriers in many different environments to many different permeating species requires different test procedures to assess the effectiveness of a given membrane for a given application. The permeating species range from a single component to highly complex mixtures such as those found in waste liquids and leachates. In specialized applications, it may be important to measure transmission or migration of a species that would take place under specific conditions and environments including temperature, vapor pressure, and concentration gradients. Tests that would be applicable to the measurement of the permeability of a material to different permeants present in various applications are summarized in Table 1.

4.1.1 In the use of geomembranes in service as barriers to the transmission of fluids, it is essential to recognize the difference between geomembranes that are nonporous, homogeneous materials and other liner materials that are porous, such as soils and concretes. The transmission of permeating species through geomembranes without holes proceeds by absorption of the species in the geomembrane and diffusion through the geomembrane on a molecular basis. The driving force is chemical potential across the geomembrane. A liquid permeates porous materials in a condensed state that can carry

the dissolved constituents, and the driving force for such permeation is hydraulic pressure. Due to the selective nature of geomembranes, the permeation of the dissolved constituents in liquids can vary greatly, that is, components of a mixture can permeate at different rates due to differences in solubility and diffusibility in a given geomembrane. With respect to the inorganic aqueous salt solution, the geomembranes are semipermeable, that is, the water can be transmitted through the geomembranes, but the ions are not transmitted. Thus, the water that is transmitted through a hole-free geomembrane does not carry dissolved inorganics. The direction of permeation of a component in the mixture is determined thermodynamically by its chemical potential difference or concentration gradient across the geomembrane. Thus, the water in the wastewater on the upstream side is at a lower potential than the less contaminated water on the downstream side and can permeate the geomembrane into the wastewater by osmosis.

4.1.2 Although inorganic salts do not permeate geomembranes, some organic species do. The rate of permeation through a geomembrane depends on the solubility of the organic in the geomembrane and the diffusibility of the organic in the geomembrane as driven by the chemical potential gradient. Principle factors that can affect the diffusion of an organic within a geomembrane include:

4.1.2.1 The solubility of the permeant in the geomembrane,

4.1.2.2 The microstructure of the polymer, for example, percent crystallinity,

4.1.2.3 Whether the condition at which diffusion is taking place is above or below the glass transition temperature of the polymer,

4.1.2.4 The other constituents in the geomembrane compound,

4.1.2.5 Variation in manufacturing processes,

4.1.2.6 The flexibility of the polymer chains,

4.1.2.7 The size and shape of the diffusing molecules,

TABLE 1 Applicable Test Method for Measuring Permeability of Geomembranes to Various Permeants

| Fluid Being Contained | Example of Permeant | Example of Field Application | Applicable Test Method and Permeant Detector and Quantifier |
|--|--|--|--|
| Single-Component Fluids: | | | |
| Gas | H ₂ , O ₂ N ₂ , CH ₄ CO ₂ | Barriers, pipe, and hose liners | D815 D1434-V D1434-P |
| Water vapor | H ₂ O | Moisture vapor barriers, water reservoir covers | E96/E96M, D653 |
| Liquid water | H ₂ O | Liners for reservoirs, dams, and canals | Soil-type permeameter with hydraulic pressure |
| Organic vapor | Organic species | Secondary containment for organic solvent and gasoline | D814, E96/E96M, F372 |
| Organic liquid | Organic solvents species | Containers, tank liners secondary containment | D814, E96/E96M |
| Multicomponents Fluids: | | | |
| Gases | CO ₂ /CH ₄ | Barriers, separation of gases | F372, GC, GCMS |
| Aqueous solutions of inorganic, for example, brines, incinerator ash leachates, leach pad leachate | Ions, salts | Pond liners | Pouch, osmotic cell, ion analysis |
| Mixtures of organics, spills, hydrocarbon fuels | Organic species | Liners for tanks and secondary containment | E96/E96M with headspace, GC |
| Aqueous solutions of organics | Organic species, H ₂ O | Liners for ponds and waste disposal | Pouch, Multicompartiment cell with analysis by GC on GCMS |
| Complex aqueous solutions of organics and inorganic species | H ₂ O, organic species, dissolved salts | Liners for waste disposal | Pouch, Multicompartiment cell, osmotic cell, analysis by head-space GC |

4.1.2.8 The temperature at which diffusion is taking place, and

4.1.2.9 The geomembrane.

4.1.3 The movement through a hole-free geomembrane of mobile species that would be encountered in service would be affected by many factors, such as:

4.1.3.1 The composition of the geomembrane with respect to the polymer and to the compound,

4.1.3.2 The thickness of the geomembrane,

4.1.3.3 The service temperature,

4.1.3.4 The temperature gradient across the geomembrane in service,

4.1.3.5 The chemical potential across the geomembrane, that includes pressure and concentration gradient,

4.1.3.6 The composition of the fluid and the mobile constituents,

4.1.3.7 The solubility of various components of an organic liquid in the particular geomembrane that increase concentration of individual components on the upstream side of the geomembrane and can cause swelling of the geomembrane resulting in increased permeability,

4.1.3.8 The ion concentration of the liquid, and

4.1.3.9 Ability of the species to move away from the surface on the downstream side.

4.1.4 Because of the great number of variables, it is important to perform permeability tests of a geomembrane under conditions that simulate as closely as possible the actual environmental conditions in which the geomembrane will be in service.

5. Significance and Uses

5.1 The principal characteristic of geomembranes is their intrinsically low permeability to a broad range of gases, vapors, and liquids, both as single-component fluids and as complex mixtures of many constituents. As low-permeable materials, geomembranes are being used in a wide range of engineering applications in geotechnical, environmental, and transportation areas as barriers to control the migration of mobile fluids and their constituents. The range of potential permeants is broad and the service conditions can differ greatly. This guide shows users test methods available for determining the permeability of geomembranes to various permeants.

5.2 The transmission of various species through a geomembrane is subject to many factors that must be assessed in order to be able to predict its effectiveness for a specific service. Permeability measurements are affected by test conditions, and measurements made by one method cannot be translated from one application to another. A wide variety of permeability tests have been devised to measure the permeability of polymeric materials; however, only a limited number of these procedures have been applied to geomembranes. Test conditions and procedures should be selected to reflect actual service requirements as closely as possible. It should be noted that field conditions may be difficult to model or maintain in the laboratory. This may impact apparent performance of geomembrane samples.

5.3 This guide discusses the mechanism of permeation of mobile chemical species through geomembranes and the per-

meability tests that are relevant to various types of applications and permeating species. Specific tests for the permeability of geomembranes to both single-component fluids and multicomponent fluids that contain a variety of permeants are described and discussed.

6. Basis of Classification

6.1 Even though geomembranes are nonporous and cannot be permeated by liquids as such, gases and vapors of liquids can permeate a geomembrane on a molecular level. Thus, even if a geomembrane is free of macroscopic holes, some components of the contained fluid can permeate and might escape the containment unit.

6.2 The basic mechanism of permeation through geomembranes is essentially the same for all permeating species. The mechanism differs from that through porous media, such as soils and concrete, which contain voids that are connected in such a way that a fluid introduced on one side will flow from void to void and emerge on the other side; thus, a liquid can flow through the voids and carry dissolved species.

6.3 Overall rate of flow through saturated porous media follows Darcy's equation that states that the flow rate is proportional to the hydraulic gradient, as is shown in the following equation:

$$Q = kiA \quad (1)$$

where:

Q = rate of flow,

k = constant (Darcy's coefficient of permeability),

A = total inside cross-sectional area of the sample container, and

i = hydraulic gradient.

6.4 With most liquids in saturated media, the flow follows Darcy's equation; however, the flow can deviate due to interactions between the liquid and the surface of the soil particles. These interactions become important in the escape of dissolved species through a low-permeability, porous liner system in a waste facility. Dissolved chemical species, either organic or inorganic, not only can permeate such a medium advectively (that is, the liquid acts as the carrier of the chemical species), but also by diffusion in accordance with Fick's two laws of diffusion.

6.5 Even though polymeric geomembranes are manufactured as solid homogeneous nonporous materials, they contain interstitial spaces between the polymer molecules through which small molecules can diffuse. Thus, all polymeric geomembranes are permeable to a degree. A permeant migrates through the geomembrane on a molecular basis by an activated diffusion process and not as a liquid. This transport process of chemical species involves three steps:

6.5.1 The solution or absorption of the permeant at the upstream surface of the geomembrane,

6.5.2 Diffusion of the dissolved species through the geomembrane, and

6.5.3 Evaporation or desorption of the permeant at the downstream surface of the geomembrane.

6.6 The driving force for this type of activated permeation process is the “activity” or chemical potential of the permeant that is analogous to mechanical potential and electrical potential in other systems. The chemical potential of the permeant decreases continuously in the direction of the permeation. Concentration is often used as a practical measure of the chemical potential.

6.7 In the transmission of a permeant through a geomembrane, Step 1 depends upon the solubility of the permeating species in the geomembrane and the relative chemical potential of the permeant on both sides of the interface. In Step 2, the diffusion through the geomembrane involves a variety of factors including size and shape of the molecules of the permeating species, and the molecular characteristics and structure of the polymeric geomembrane. A steady state of the flow of the constituents will be established when, at every point within the geomembrane, flow can be defined by Fick’s first law of diffusion:

$$Q_i = -D_i \frac{dc_i}{dx} \quad (2)$$

where:

- Q_i = mass flow of constituent “i,” $\text{g cm}^2 \text{s}^{-1}$,
- D_i = diffusivity of constituent “i,” $\text{cm}^2 \text{s}^{-1}$,
- c_i = concentration of constituent “i,” g cm^3 , and
- x = thickness of the geomembrane, cm.

6.7.1 It should be noted that the concentration of constituent “i” referred to in Fick’s law is within the mass of the geomembrane.

6.7.2 Step 3 is similar to the first step and depends on the relative chemical potential of the permeant on both sides of the interface at the downstream geomembrane surface.

6.8 Chemical potential is a thermodynamic concept that indicates the direction in which the permeation will go, that is, from high to low potential. To use concentration directly to replace chemical potential requires the individual molecules of the permeating species to neither interact with each other nor with the membrane they are permeating. This condition approximately exists when a permanent or a noncondensable gas, such as oxygen, nitrogen, or helium, permeates a membrane. However, the individual molecules of organic species can interact with each other and with the polymer to increase solubility of the species in the geomembrane.

7. Test Methods

7.1 *Permeability of Geomembranes to Single-Component Fluids*—Many of the applications of geomembranes are for barriers to the permeation of single-component permeants, that is, a single gas, vapor, or liquid. With respect to water, such applications include reservoir liners, moisture vapor transmission barriers, floating covers for reservoirs, canal liners, and tunnel liners; other applications involving single-component fluids would also include liners for secondary containment. Other applications might be methane barriers in tunnels, MSW landfills, and buildings built near methane and hydrocarbon sources. Various tests that are appropriate for assessing barriers to the permeation of different types of single-component fluids are discussed in the following paragraphs.

7.1.1 Permeability of Geomembranes to Single Gases:

7.1.1.1 For such applications as linings for waste disposal facilities and methane barriers, the permeability to gases is important in geomembrane selection. The permeability of geomembranes can be assessed by measurement of the volume of the gas passing through the geomembrane under specific conditions or by measurement of the increase in pressure on the evacuated downstream side. Both methods are described in Test Method D1434. The apparatus used for the volumetric method is shown schematically in Fig. 1 (see Ref (1)).⁴

7.1.1.2 The volumetric method has been used to measure the permeability of a wide range of geomembranes to methane, carbon dioxide, and nitrogen. In this procedure, the geomembrane is in contact with the gas on both sides, that is, on the upstream side at a pressure greater than atmospheric and on the downstream side at atmospheric pressure to yield a concentration gradient and diffusion of the gas in the geomembrane. Other variables that should be considered in assessing the gas transmission rate (GTR) of a given gas include thickness and such test conditions as temperature and pressure.

7.1.2 Permeability of Geomembranes to Water:

7.1.2.1 *Permeability to Moisture Vapor*—For applications such as reservoir covers and moisture barriers, permeability to moisture vapor can be measured by a variety of methods that reflect the service conditions. Determinations can be made by measuring the change in weight of a small cup that contains

⁴ The boldface numbers given in parentheses refer to a list of references at the end of the text.

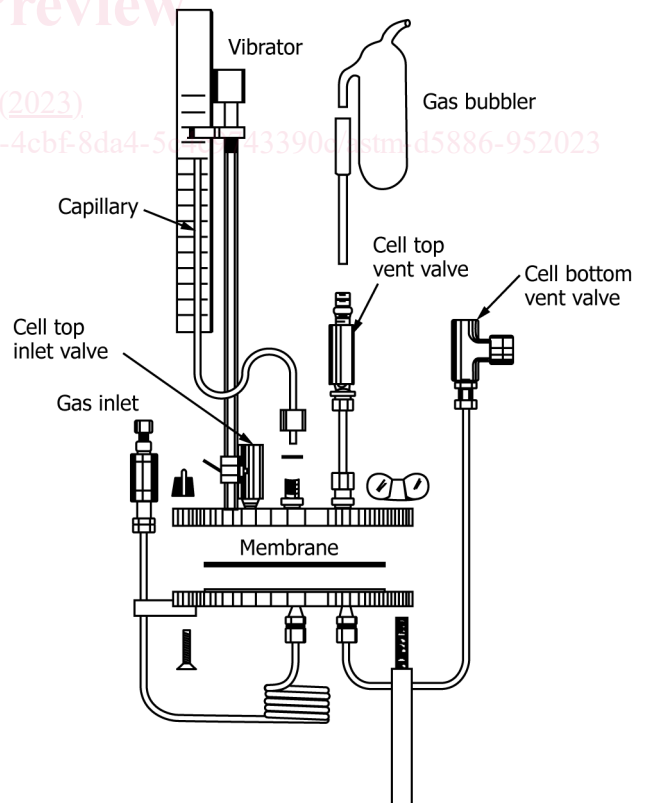

FIG. 1 Gas Permeability Apparatus in Test Method D1434, Procedure V – Volumetric (1)

either a small amount of distilled water or a desiccant and is sealed at the mouth with a specimen of the geomembrane, for example, Test Methods E96/E96M. An example of the type of cup that is used in this test is shown in Fig. 2 (see Refs (1, 2)).

7.1.2.2 *Permeability to Water*—Under a head of water comparable to that encountered in a water reservoir, the pressure on the surface of a geomembrane can cause a small transmission of water through the geomembrane. Various measurements of water-permeating geomembranes have been made in which pressure has been applied across a geomembrane with the water on the downstream side at atmospheric pressure. The amount of deaerated water that was transmitted through the membrane was measured on the downstream side. This type of permeability test applies only to water or waters of zero or equal concentration of dissolved constituents on both sides of the geomembrane. A brine or a waste liquid on the upstream side and high-purity water on the downstream side could reverse the direction of permeation of water due to osmotic pressure (see Ref (3)).

7.1.3 *Permeability of Geomembranes to Organics:*

7.1.3.1 The moisture vapor transmission type of test can be used to assess the permeability of various membranes to solvent vapors. In this case, the cup that is used in the moisture vapor transmission test is exposed with the solvent vapor contacting the membrane. The vapor concentration inside the cup is that of the vapor pressure at the test temperature and the concentration outside the cup is essentially zero. Therefore, the

vapor pressure gradient is the vapor pressure of the solvent at the temperature of test if the vapor concentration is held constant.

7.1.3.2 Another test method that can be used for measuring permeability to organic vapors is Test Method F739, that is used to measure the resistance of protective clothing materials to the permeation of liquids or gases. In Test Method F739, an analytical detection system is used to measure the time to breakthrough of the permeant and the equilibrium rate of permeation.

7.1.3.3 For those applications in which geomembranes will be contacted by organic liquids, such as liners for tanks and secondary containment, it is necessary first to determine the compatibility of the specific membrane with the specific organic that is to be contained. This is necessary because of the potential swelling of the geomembrane which can change the permeability.

7.1.3.4 Compatibility testing has been used in the rubber and plastics industries for assessing compatibility of coatings and lining materials for equipment and pipes. A test commonly used for this purpose is Test Method D471 that will indicate whether the material under test will swell during the test and change the permeability of the test specimen during the test. Once compatibility has been demonstrated, tests such as Test Methods E96/E96M or D814, in which the solvent contacts the specimen, can be used and treated in a similar fashion to modified Test Methods E96/E96M as shown in Fig. 3 (see Ref (1)).

7.2 *Permeability of Geomembranes to Multicomponent Fluids*—Many of the applications of geomembranes as barriers involve contact with multicomponent fluids, for example, mixtures of gases, liquids, and aqueous solutions of salts or organics, or both. The most complex of such mixtures are probably leachates from waste disposal facilities. In considering geomembranes for these applications, one must recognize

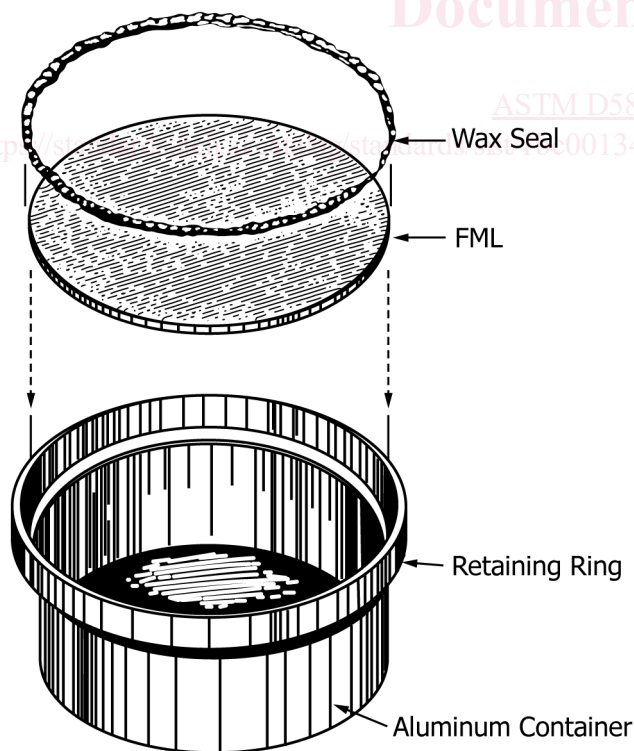

NOTE 1—In the test procedure, the cup is kept in an inverted position so that water sealed in the cup contacts the FML surface (1).

FIG. 2 Exploded View of Water Vapor Transmission Cup Used in Test Methods E96/E96M

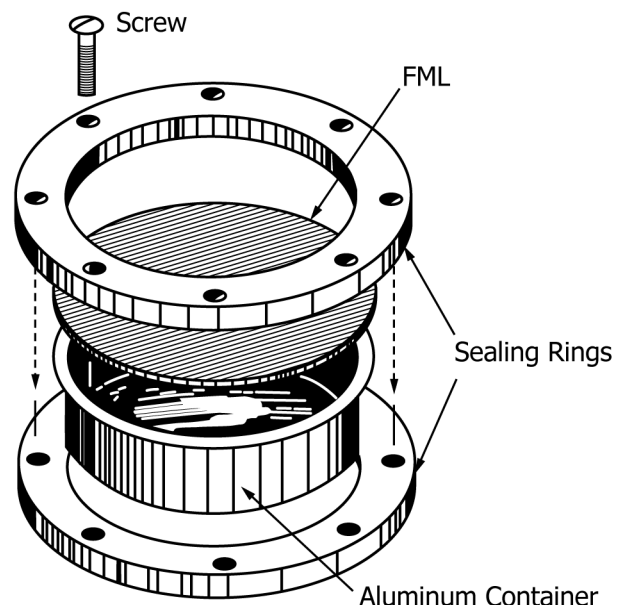

FIG. 3 Exploded View of SVT Cup with Aluminum Sealing Rings (1)