



Designation: D4680 – 98 (Reapproved 2023)

Standard Test Method for Creep and Time to Failure of Adhesives in Static Shear by Compression Loading (Wood-to-Wood)¹

This standard is issued under the fixed designation D4680; the number immediately following the designation indicates the year of original adoption or, in the case of revision, the year of last revision. A number in parentheses indicates the year of last reapproval. A superscript epsilon (ϵ) indicates an editorial change since the last revision or reapproval.

1. Scope

1.1 This test method covers the determination of time-dependent properties of structural adhesives in wood-to-wood bonds when specimens are subjected to shearing stresses at various levels of static load, constant temperature, and relative humidity. Apparatus and procedures are provided for direct measurement of time-dependent shear deformation (creep) and time to failure of adhesive bonds under static load. Guidelines for selecting test conditions, methods for calculating creep rate, creep strain, creep modulus, and extrapolation of time to failure, are given along with methods of presenting these data.

1.2 The values stated in inch-pound units are to be regarded as standard. The values given in parentheses are mathematical conversions to SI units that are provided for information only and are not considered standard.

1.3 *This standard does not purport to address all of the safety concerns, if any, associated with its use. It is the responsibility of the user of this standard to establish appropriate safety, health, and environmental practices and determine the applicability of regulatory limitations prior to use.*

1.4 *This international standard was developed in accordance with internationally recognized principles on standardization established in the Decision on Principles for the Development of International Standards, Guides and Recommendations issued by the World Trade Organization Technical Barriers to Trade (TBT) Committee.*

2. Referenced Documents

2.1 *ASTM Standards:*²

- D143 Test Methods for Small Clear Specimens of Timber
- D905 Test Method for Strength Properties of Adhesive Bonds in Shear by Compression Loading

¹ This test method is under the jurisdiction of ASTM Committee D14 on Adhesives and is the direct responsibility of Subcommittee D14.30 on Wood Adhesives.

Current edition approved May 1, 2023. Published May 2023. Originally approved in 1987. Last previous edition approved in 2017 as D4680 – 98 (2017). DOI: 10.1520/D4680-98R23.

² For referenced ASTM standards, visit the ASTM website, www.astm.org, or contact ASTM Customer Service at service@astm.org. For *Annual Book of ASTM Standards* volume information, refer to the standard's Document Summary page on the ASTM website.

D907 Terminology of Adhesives

D2016 Methods of Test for Moisture Content of Wood (Withdrawn 1987)³

2.2 *ASTM Adjuncts:*

Compression-Shear Creep Test Apparatus⁴

3. Terminology

3.1 *Definitions:*

3.1.1 Many terms in these test methods are defined in Terminology D907.

3.1.2 *creep, n*—the dimensional change with time of a material under load, following the initial instantaneous elastic or rapid deformation. Creep at room temperature is sometimes called cold flow.

3.1.3 *creep modulus, n*—the ratio of initial applied stress to creep strain.

3.1.4 *creep strain, n*—the total strain, at any given time, produced by the applied stress during a creep test.

3.1.4.1 *Discussion*—In this test method, creep strain is calculated by dividing displacement at any given time by the estimated apparent thickness of the adhesive bondline.

3.1.5 *rate of creep, n*—the slope of the creep-time curve at a given time.

3.1.6 *shear stress, n*—the stress component tangential to the plane on which the forces act, that is, in the plane of the bond line.

3.1.7 *strain, n*—the unit change, due to stress, in the size or shape of a body referred to its original size or shape.

3.1.8 *stress, n*—the force exerted per unit area at a point within the plane.

4. Significance and Use

4.1 Creep data that are obtained over a relatively short period of time in this test method can provide a measure of an adhesive bond's ability to withstand static loading in shear over a relatively long period of time. Creep measurements are made

³ The last approved version of this historical standard is referenced on www.astm.org.

⁴ Available from ASTM International Headquarters. Order Adjunct No. ADJD4680. Original adjunct produced in 1987.

over a range of expected service conditions, including level of stress, temperature, relative humidity, and duration of load. Creep rate, creep strain, and creep modulus are calculated at the various service conditions.

4.2 Creep data can be used to (1) predict performance of an adhesive under long-term loading, (2) characterize an adhesive, (3) compare adhesives with each other and against specifications, and (4) design structural members fabricated with an adhesive.

4.3 Time-to-failure data provide a measure of the ultimate load-carrying ability of an adhesive bond as a function of time at various levels of stress, temperature, and relative humidity.

4.4 With proper caution, time-to-failure data derived from relatively short loading periods can be extrapolated to estimate the useful service life of an adhesive at working levels of static stress. This property may also be used with creep data to accomplish purposes listed in 4.2.

4.5 This test method is a research tool intended for development or evaluation of new adhesives and new product designs. The researcher may select from suggested tests those that are appropriate. However, creep and time-to-failure tests are nonroutine and can be time-consuming and expensive, so tests must be selected with care.

4.6 The apparatus and procedures may be suitable for measuring creep properties of adhesives on substrates other than wood, such as metal, plastic, and glass, but such considerations are not within the scope of this test method.

5. Apparatus

5.1 *Testing Machine*—A testing machine, or other suitable loading machine, capable of applying compression loads from 0 lbf to 5000 lbf (22 kN) and cross-head speeds from 0.01 in./min to 0.40 in./min (0.3 mm/min to 10.2 mm/min) is sufficient for this test method. A minimum vertical space of 20 in. (508 mm) is required to compress the loading spring in the creep-test apparatus.

5.2 *Compression Shearing Tool*—The testing machine is equipped with a shearing tool capable of applying a uniformly distributed compression load to the loading ledges of the block-shear specimen. A shearing tool equipped with a self-aligning seat in the shearing blade ensures uniform loading.

5.3 *Creep-Test Apparatus*—Static loads shall be applied and maintained on block-shear specimens by means of the compression-loaded creep-test cylinder shown in Fig. 1.^{5,4} The apparatus is spring-loaded and can sustain any load up to the design capacity of the spring. This particular spring has a design load of 2300 lbf (10 kN); however, others of greater or less capacity may be substituted. Varying spring capacities with outside diameters no greater than the cylinder inside diameter are available.

5.3.1 For creep tests above room temperature, it is not necessary to adjust the spring or load to compensate for the effects of changing temperature. It is only necessary that the

apparatus, with included specimen, be preconditioned to the test temperature before the test load is applied to the spring. The preheated apparatus must be wrapped with a piece of flexible thermal insulation material while the test load is applied to the specimen. After loading and measurements, return the loaded apparatus to the test environment. Since there are no significant changes in temperature before or after loading, no adjustments are needed in the spring.

5.3.2 The creep-test apparatus is made of corrosion-resistant components so that it can be used in high-temperature and humid environments for prolonged periods without concern for damaging the apparatus or interfering with the effectiveness of the test.

5.3.3 The creep-test apparatus has been compactly designed with its load-applying mechanism built-in. Thus, several of the units may be stacked on racks in a small environmental chamber such as an oven, incubator, or humidity cabinet. The apparatus may be transferred from one exposure chamber to another, or may be removed from an exposure chamber for measurements without disturbing the specimen under static load.

5.3.4 The creep-test apparatus shown in Fig. 1 has a microswitch mounted at its base which is activated when the creep specimen fails. A small pin is located in the lower specimen seat which is driven against the microswitch when the failed specimen strikes it. The microswitch must be connected to an automatic timer-recorder.

5.4 *Automatic Timer-Recorder*—If creep or time-to-failure measurements are to be made, an automatic and multi-channel timer-recorder is connected to the microswitch on each creep-test apparatus. The timer-recorder is capable of automatically scanning the several connected circuits at selected intervals of time. When the creep specimen fails and activates the microswitch, the timer-recorder automatically records the time at which the circuit is broken.

5.5 *Microscope*—A microscope is required to measure displacement of scribe marks across the two adherends of a specimen as creep occurs. Accurate measurements are also required for bondline thicknesses. Make measurements to the nearest 0.001 mm (0.0004 in.). A linear traveling binocular microscope is ideally suited to creep measurements; however, a microscope fitted with an appropriately graduated scale is satisfactory. An objective lens of at least 7× magnification is required.

5.6 *Environmental Chambers*—Control of temperature and relative humidity is required in creep tests of adhesive bonds on wood substrates. Temperature has a profound effect on creep properties of adhesives. Humidity also affects creep of certain adhesives, but it can also affect dimensional change in wood adherends. Conditioning equipment should be capable of maintaining a constant temperature within ± 3.0 °F (± 1.7 °C) of the set-point and constant relative humidity within ± 5 % of the set-point at a given temperature.

6. Materials

6.1 *Adherends*—Select sugar maple (*Acer saccharum*) as the standard adherend material with the grain of the wood straight

⁵ This creep-test apparatus may be purchased from Hull Machine Shop, P.O. 373, Hull, GA 30646, or other suitable suppliers.

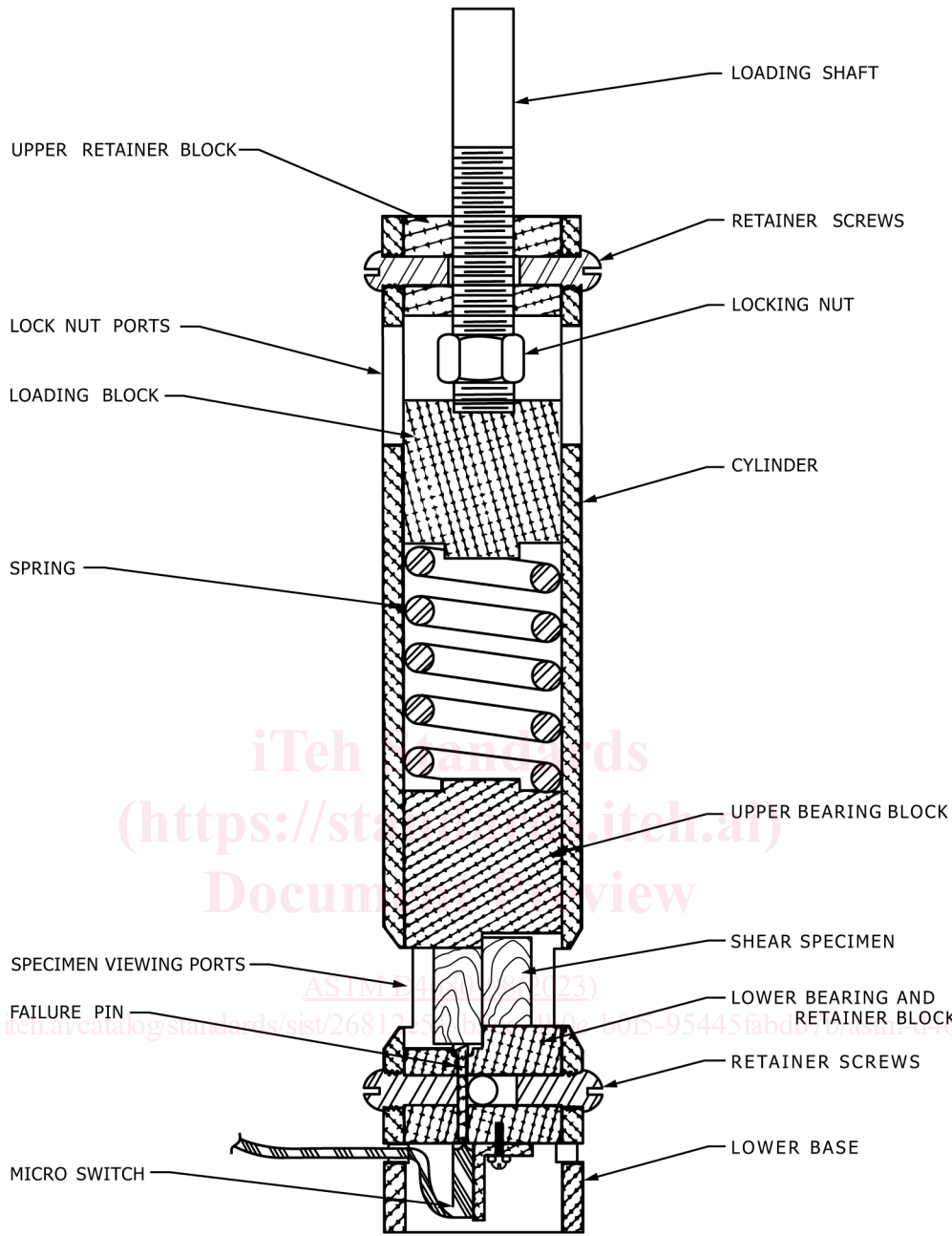

FIG. 1 Creep Test Apparatus

and parallel to the direction of shear and free of all defects such as knots, splits, and discolorations. Sugar maple is a uniformly textured and high-density wood preferred in creep tests because it is less likely to deform near the bondline or fail in the wood before the test is completed.

6.1.1 Sugar maple adherend material has a minimum specific gravity of 0.65 (based on oven-dry weight and volume). A method for selecting maple blocks at this specific gravity, including appropriate adjustments in specific gravity for various moisture contents, is described in the Appendix of Test Method D905. If more complete procedures are required for refereed tests, specific gravity may be determined in accordance with Section 116 of Test Methods D143.

6.1.2 Any other species of wood may be used as adherend material, particularly in those cases where it is necessary to know the creep behavior of an adhesive in contact with a specific wood species. However, it should be recognized that woods that are less uniform in texture and lower in density than sugar maple, are more likely to deform and fail prematurely.

6.1.3 When conducting creep and time-to-failure tests, it is important not to overload the adherend and cause deformation at the bondline or failure in the wood before the test is completed. As a guide to selecting maximum levels of stress, it is recommended that the load not exceed the average shear strength parallel-to-grain for the species of wood when adjusted for any change in moisture content from 12 %. Average

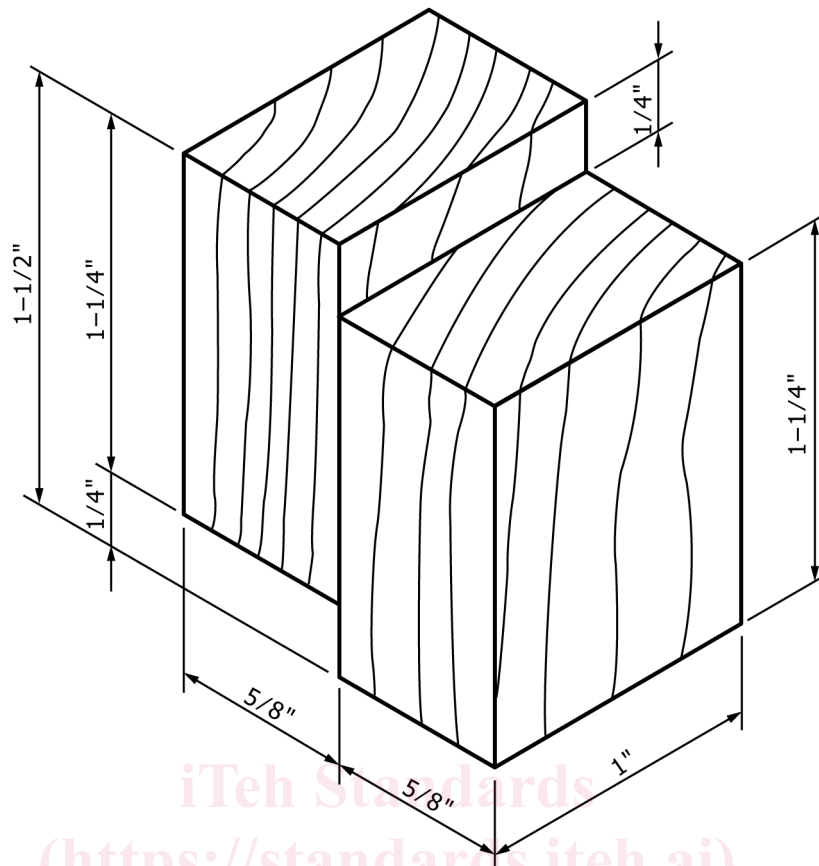

FIG. 2 Block-Shear Specimen for Creep and Time To Failure Tests

shear strengths at 12 % moisture content for sugar maple and other species of wood are presented in Table 4-2 of the Wood Handbook.⁶ For moisture contents other than 12 %, it will be necessary to adjust shear strengths by the formula described in pp. 4-32 and 4-33 of the Wood Handbook.⁶

6.1.4 Should premature failures occur in the wood after mean strength values have been adjusted for moisture content, then the 5 % exclusion limit may be used to select the maximum level of stress for a particular species of wood. The maximum level of stress $S_{\max 0.05}$ is determined by the following equation:

$$S_{\max 0.05} = S_m - 1.645(0.14S_m) \quad (1)$$

where S_m is the mean shear strength parallel-to-grain as presented in Table 4-2 of the Wood Handbook.⁶

6.2 *Adhesives*—Creep properties of any adhesive can be measured on any species of wood as long as the level of shear stress does not exceed the shear strength of the wood in the specimen.

7. Test Specimens

7.1 The standard specimen for both creep and time-to-failure tests shall be the block-shear specimen illustrated in

Fig. 2. Use the test adhesive to bond the two hard maple adherends together. The shear area is 1.00 in. by 1.00 in. (2.54 cm by 2.54 cm), equalling 1.00 in.² (6.45 cm²).

7.2 The finished specimen for creep tests has well-defined scribe marks on each side of the specimen for measuring displacement of the two adherends as creep takes place.

7.3 Scribe marks are not necessary for specimens intended for the time-to-failure tests.

7.4 Number of Specimens:

7.4.1 Test at least ten specimens at each set of test conditions, that is, each combination of stress level, temperature, and relative humidity, for either creep test or time-to-failure test. It is suggested that at least one test joint assembly (contains twelve specimens) be prepared for each combination of test conditions.

7.4.2 Randomly assign the ten specimens for each set of test conditions to that set from the entire lot of specimens prepared for testing of a given adhesive.

7.4.3 For many adhesives, measured creep properties will be highly variable, and ten specimens may not be a large enough sample to give a high degree of confidence to the mean of a measured property. Creep tests generally are expensive and time-consuming, and a specimen count of ten represents a practical compromise.

7.4.4 If it is determined from experimental evidence that a reasonable degree of confidence can be given to a mean by

⁶ Wood Handbook: Wood As An Engineering Material, USDA Agriculture Handbook 72, rev., U.S. Forest Products Lab., 1974, Table 4-2 and p. 4-32 and 4-33. Available from U.S. Government Printing Office Superintendent of Documents, 732 N. Capitol St., NW, Mail Stop: SDE, Washington, DC 20401.

using a lesser number of specimens, then it is permissible to use the lesser number.

8. Conditioning of Materials and Specimens

8.1 Condition hard maple boards at $73\text{ °F} \pm 3\text{ °F}$ ($23\text{ °C} \pm 1.7\text{ °C}$) and $65\% \pm 2\%$ relative humidity until they reach moisture equilibrium (approximately 12 % moisture content), as indicated by no further significant changes in weight. Use Test Methods **D2016** for guidance to determine when equilibrium has been reached. Other relative humidities may be substituted as long as (1) the wood reaches equilibrium between 10 % and 12 % moisture content, (2) the alternative conditions are substituted consistently throughout the test method, and (3) the substituted standard conditions are reported. If the facilities are not available for conditioning wood to the 10 % to 12 % moisture content range, then lower relative humidities may be substituted to lower the equilibrium moisture content of the wood to the 7 % to 9 % range. Conditions (2) and (3) above must apply to this substitution.

8.2 It is important that wood moisture content after preconditioning and during creep tests remain essentially the same. Otherwise adherends will undergo dimensional changes with moisture during static loading with the inevitable result that creep properties will be affected. The exposure environment for creep tests shall be the same as indicated in **8.1**, unless otherwise prescribed.

NOTE 1—Guidelines for selecting test conditions are given in **Annex A1**.

9. Specimen Preparation

9.1 Plane hard maple boards of specified specific gravity on both sides to a thickness of 0.63 in. (16 mm). If a planer is not available, use a hand-fed jointer. Planing should be carried out no longer than 24 h before bonding. Cut the boards into blocks 12 in. long by 3 in. wide (30.5 cm by 7.6 cm). The grain direction shall be parallel to the long dimensions of the block. Keep the planed surfaces free of dust and dirt until they can be bonded.

9.2 Prepare the test adhesive and apply it to adherends in accordance with procedures recommended by the manufacturer of the adhesive. Since adhesives of different types may be tested by this method, no given set of spread rates, assembly times, clamp pressures, pressure times, and curing times, can be specified to cover all adhesives. Normally, the adhesive manufacturer describes procedures for making sound bonds and these should be carefully followed.

9.3 After proper curing, cut each test joint assembly into twelve specimen blanks. The method of cutting specimens from an assembly is shown in Fig. 3 of Test Method **D905**, although assembly and specimen dimensions are different. To make cutting of specimen blanks easier, trim one outside edge from the joint assembly. From this edge, make the second and third full-length cuts the exact width of block-shear specimens. Afterwards, these two strips can be cross-cut to the exact length of specimens. With specimen blanks cut to exact overall dimensions, notch the loading ledges to give a shear area 1.00 in. (2.54 cm) long as illustrated in **Fig. 2**. After cutting, return

the finished block-shear specimens to the standard atmosphere given in **8.1**. Condition them there for 7 days to ensure that the moisture content has stabilized before creep tests begin. If creep tests are to be conducted at equilibrium moisture conditions other than those in **8.1**, then subsequent conditioning will be required as described in **10.1.2**.

9.4 Cut scribe marks along the two sides of each specimen intended for creep tests. A sharp, single-edged razor blade makes well-defined marks. The marks extend in a straight line across, and perpendicular to the bondline and adherends. Inspect the cuts with any microscope fitted with an objective lens of 7× magnification. If at least one edge of the cut is not clearly defined, then make another cut next to the first. Be sure to use the same cut edge every time measurements are made.

10. Procedure

10.1 Creep Tests:

10.1.1 Randomly select and assign at least ten specimens to each set of test conditions from the total number of specimens that are to be used for the creep tests. Select an additional set of specimens to replace defective or mis-tested specimens.

10.1.2 Since creep specimens of wood undergo dimensional changes with changes in environment, it is essential that specimens be preconditioned to, and in equilibrium with, those test conditions at the time creep tests begin. If creep is to be measured at conditions other than standard conditions in **8.1**, then condition specimens at those test conditions until specimens reach equilibrium moisture content (indicated by no change in weight) and temperature.

10.1.3 After specimens have been preconditioned, measure the shear area of each creep specimen to the nearest 0.01 in. (0.25 mm) using a dial-indicating calipered micrometer. Calculate the shear area to the nearest 0.01 in.² (0.06 cm²).

10.1.4 Measure bondline thickness at the four corners of the shear area on each specimen to the nearest 0.0004 in. (0.001 mm) with a linear traveling microscope, or with a microscope having a graduated scale. The bondline thickness for each specimen shall be the average of the four measurements.

10.1.5 If creep is to be determined for elevated temperatures, but specimens have to be removed from test conditions for periodic measurements of creep, the creep test apparatus along with a properly seated specimen must be conditioned to equilibrium temperature before removal from test conditions. Every effort should be made to maintain test temperature when apparatus and specimen are removed for measurements. This can be accomplished by wrapping the apparatus in a flexible thermal insulation material such as polyurethane foam until measurements can be completed. Creep measurements require only a few minutes, so dimensional changes from loss or gain of moisture should not be of any consequence.

10.1.6 Mount a properly conditioned and measured creep specimen on the loading seats of the creep-test apparatus. Position the apparatus in the testing machine to apply a compression load to the loading shaft of the apparatus. If a microswitch is attached to the base of the creep apparatus, support the apparatus on the lower base shown in **Fig. 1** when

applying test loads. Apply the predetermined test load to the loading shaft (which compresses the loading spring) at a uniform rate of speed such that the test load is reached within 1 min. When the test load is reached, begin measurements of time. Turn the keeper-nut on the loading shaft until it firmly seats against the upper end-plug. This ensures that the deflection of the loading spring will remain constant throughout the creep test. Remove the apparatus from the testing machine.

10.1.7 Immediately begin measuring displacement of scribe marks on each side of the specimen with the traveling microscope. Make measurements at the following time intervals: 1, 2, 5, 10, 20, 50, 100, 200, 500, 1000, 2000–100,000 min. These intervals and total loading times are suggested, and may be adjusted as deemed appropriate. The intervals provide approximately equally spaced points when plotted along the logarithmic base – 10 scale of time. If discontinuities in the creep strain-versus-time curve are suspected, take readings more frequently than scheduled above.

10.1.8 On completion of initially planned creep measurements, and before failure occurs, it may be desirable to measure recovery at some point in creep development. If so, reposition the creep apparatus in the testing machine and lower the cross-head to just contact the loading shaft. Loosen the keeper-nut enough to allow the spring to make full recovery. Then reverse the cross-head direction and remove the load within 1 min. Begin timing immediately and make measurements of displacement recovery according to the same time interval schedule shown in 10.1.7. After each recovery measurement, return the apparatus with specimen to the appropriate test environment until all measurements are completed. After recovery measurements, if specimens are to be re-loaded for additional creep measurements, repeat procedures in 10.1.6 and 10.1.7.

10.1.9 Continue the creep test until failure if desired.

10.2 Time-to-Failure Tests:

10.2.1 Randomly select and assign ten specimens to each set of test conditions from the total number of specimens that are to be used for time-to-failure tests. From the same larger group, randomly select 20 specimens for determining average ultimate shear strength. An additional set of ten specimens should be selected to replace defective or mis-tested specimens.

10.2.2 Measure the shear area and bondline thickness of each specimen as described in 10.1.3 and 10.1.4.

10.2.3 With properly conditioned, measured, and randomly selected specimens, determine average ultimate shear strength from 20 specimens according to procedures in Sections 2 and 7 of Test Method D905. For rigid adhesives, use the specified cross-head speed of 0.015 in. (0.00635 mm/min) in Test Method D905. This speed should produce failure in about 1 min. For less rigid adhesives where appropriate cross-head speeds are not known, select a speed that will produce failure within 1 min. Calculate the shear strength at failure in pounds-force per square inch (kilopascals), based on the bondline area measured in 10.1.3.

10.2.4 Use at least four points, and preferably more, to establish a curve of time to failure versus level of stress. These points should be evenly spaced over the range of stresses to be

tested. It is suggested that specimens be loaded at 90 %, 80 %, 70 %, and 60 % of the ultimate shear strength of the adhesive, as determined in 10.2.4. Other stress levels may be selected, but it is desirable that the lowest stress level produce average time to failure near 3000 h.

10.2.5 Apply appropriate static loads to properly conditioned and measured specimens with the creep-test apparatus, as described in 10.1.6. Attach the microswitch to the apparatus base and connect it to the automatic time-recording device before applying test loads. Activate the timer when the test load is reached.

10.2.6 After removing the creep-test apparatus from the testing machine, return the load specimen to the appropriate testing environment. Handle the apparatus carefully to avoid bumps or vibrations that may produce premature failure in specimens under static loading. Continue loading until failure occurs. Record the time of failure.

10.2.7 The failed specimen must be removed from the creep-test apparatus using the testing machine. Reposition the apparatus in the testing machine and lower the cross-head to just contact the loading shaft. Loosen the keeper-nut so the spring can make a full recovery. Raise the cross-head and remove the apparatus.

11. Calculation

11.1 Calculate stresses for each specimen in pounds-force per square inch (kilopascals) by dividing the load by the initial shear area. Calculate percentage of ultimate shear stress by dividing test shear stress by ultimate shear stress and multiplying the quotient by 100.

11.2 Calculate creep strain in inches per inch (millimetres per millimetre) by dividing total displacement of scribe marks (average of two sides) at times specified in 10.1.7 by bondline thickness (average of four corners).

11.3 Calculate creep modulus in pounds-force per square inch (kilopascals) by dividing the initial stress by creep strain at the times specified in 10.1.7.

11.4 Calculate a least-squares linear regression equation of stress (expressed as percent of ultimate shear stress) over log base – 10 time to failure. A better-fitting curve may be obtained by calculating a linear regression equation of log base – 10 of stress level over log base – 10 of time to failure. Calculate an equation for each temperature (and relative humidity) at which time-to-failure tests were conducted. From these equations, calculate the time-to-failure at projected lower stress levels than those tested. Usually working stress levels will be considerably lower, in which case extrapolations may extend beyond actual data. Normally, extrapolation should be limited to one base – 10 log cycle.

11.5 Calculate the rate of creep from the curve of creep strain versus time. Draw a straight line to coincide with the region of secondary creep in the creep curve. This region of secondary creep usually has the least slope, compared to slopes of the curve in primary and tertiary regions. The minimum creep rate is the quotient of creep strain over time at any point along the straight line in the secondary creep region.

12. Report

12.1 Prepare a complete report of all tests. Creep data cannot be collected as quickly as needed, so tests may span up to two or more years. These tests are quite expensive in terms of personnel and equipment requirements. Also, several different people may work on the project, and equipment may be changed. For these reasons, a clear and detailed report can provide the needed continuity, and perhaps avoid repeating tests.

12.2 Such values as creep rate and time to failure can differ by as much as several times from one specimen to another, even when specimens are prepared at the same time and in the same way. Therefore, descriptions of materials and equipment should be as complete as possible, and should include the following:

12.2.1 Description of adherends, including wood species, density, grain direction, orientation of grain with respect to bondline, and equilibrium moisture content at time of assembly.

12.2.2 Description of adhesives, including type, composition, trade name, date of manufacture, and lot number.

12.2.3 Complete details of adhesive mixing, application, and joint assembly, used in preparing the specimens. Include description of mixing equipment, time and temperature of mixing, pot-life of adhesive, and time delay between applying adhesive to first and last specimens (number sequentially). Described method of spreading adhesive, adhesive spread rate, time of open or closed assembly, temperature and relative humidity at time of assembly. Include details on adhesive setting, such as method of applying pressure to joints, pressure, time of pressure, and temperature and relative humidity while setting. In general, provide enough information to enable

another operator to repeat, or trace a discrepancy in, specimen preparation procedures.

12.2.4 Dimensions of shear area and bondline thickness in all specimens.

12.2.5 Preconditioning and test conditions, including temperature, relative humidity, and time of exposure to these conditions.

12.2.6 Description of testing equipment, including make, model, and capacity of manufactured equipment, such as testing machine, shearing tool, timer-recorder, microscope, and environmental chambers. A drawing of the creep-test apparatus shown in Fig. 1 shall be included in the report.

12.2.7 Number of specimens tested at each test condition.

12.2.8 Rates of loading for creep and time-to-failure tests. Also rate of loading for determining ultimate shear strength of adhesives.

12.2.9 Stress levels for all tests of creep and time to failure at each set of temperature and relative humidity conditions.

12.2.10 Measurements of creep strain and time, and time to failure, for all levels of stress, temperature and relative humidity, for each specimen.

12.2.11 For each specimen, a plot of shear displacement versus time with minimum creep rate indicated by a straight line drawn to coincide with the region of secondary creep.

12.2.12 For each test temperature, a family of stress – strain curves with time as a parameter, as illustrated in Fig. 3.

12.2.13 For each test temperature, a plot of log base – 10 of creep strain versus log base – 10 of time with stress as a parameter, as illustrated in Fig. 4.

12.2.14 For each test temperature, a plot of log base – 10 of creep modulus versus log base – 10 of time with stress as a parameter, as illustrated in Fig. 5.

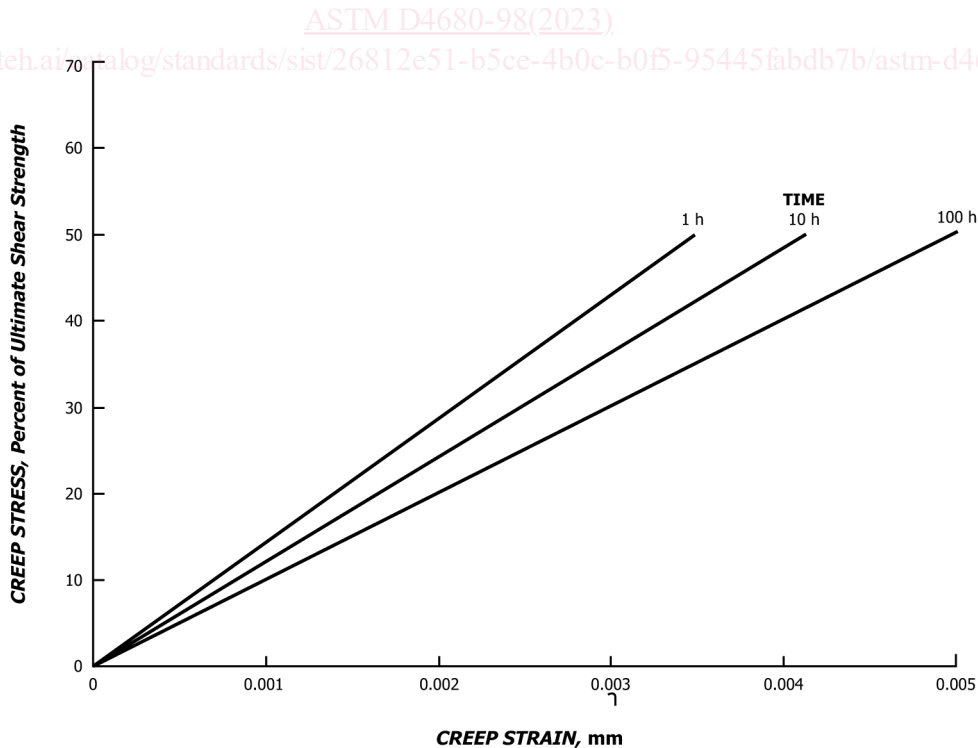

FIG. 3 Stress-Strain Curves at Various Times