



Designation: C965 – 23

Standard Practice for Measuring Viscosity of Glass Above the Softening Point¹

This standard is issued under the fixed designation C965; the number immediately following the designation indicates the year of original adoption or, in the case of revision, the year of last revision. A number in parentheses indicates the year of last reapproval. A superscript epsilon (ϵ) indicates an editorial change since the last revision or reapproval.

1. Scope

1.1 This practice covers the determination of the viscosity of glass above the softening point through the use of a platinum alloy spindle immersed in a crucible of molten glass. Spindle torque, developed by differential angular velocity between crucible and spindle, is measured and used to calculate viscosity. Generally, data are taken as a function of temperature to describe the viscosity curve for the glass, usually in the range from 1 to 10^6 Pa·s.

1.2 Two procedures with comparable precision and accuracy are described and differ in the manner for developing spindle torque. Procedure A employs a stationary crucible and a rotated spindle. Procedure B uses a rotating crucible in combination with a fixed spindle.

1.3 *This standard does not purport to address all of the safety concerns, if any, associated with its use. It is the responsibility of the user of this standard to establish appropriate safety, health, and environmental practices and determine the applicability of regulatory limitations prior to use.*

1.4 *This international standard was developed in accordance with internationally recognized principles on standardization established in the Decision on Principles for the Development of International Standards, Guides and Recommendations issued by the World Trade Organization Technical Barriers to Trade (TBT) Committee.*

2. Referenced Documents

2.1 *ASTM Standards:*²

[C162 Terminology of Glass and Glass Products](#)

[E220 Test Method for Calibration of Thermocouples By Comparison Techniques](#)

¹ This practice is under the jurisdiction of ASTM Committee C14 on Glass and Glass Products and is the direct responsibility of Subcommittee C14.04 on Physical and Mechanical Properties.

Current edition approved May 1, 2023. Published May 2023. Originally approved in 1981. Last previous edition approved in 2017 as C965 – 96 (2017). DOI: 10.1520/C0965-23.

² For referenced ASTM standards, visit the ASTM website, www.astm.org, or contact ASTM Customer Service at service@astm.org. For *Annual Book of ASTM Standards* volume information, refer to the standard's Document Summary page on the ASTM website.

3. Significance and Use

3.1 This practice is useful in determining the viscosity-temperature relationships for glasses and corresponding useful working ranges. See Terminology C162.

4. Apparatus

4.1 The apparatus shall consist of an electrically heated furnace equipped with a temperature controller, temperature measuring equipment, a platinum alloy spindle, a crucible, a device to rotate spindle or crucible, and equipment to measure torque.

NOTE 1—Spindles and crucibles manufactured from 90 % Pt–10 % Rh or 80 % Pt–20 % Rh alloys have been found satisfactory for this purpose.

4.1.1 Procedure A employs an electrically heated tube-type furnace with a fixed support for the crucible as shown in Fig. 1. A platinum alloy resistance-heated crucible also may be used.

4.1.2 Procedure B employs a similar furnace but with a removable, rotatable crucible support as shown in Fig. 2.

4.1.3 Furnaces other than resistance-wound muffle types may be used provided they give uniform and stable temperature conditions. Temperature differences greater than 3 °C within the crucible (in glass) are excessive for high precision measurements.

4.1.4 A temperature controller shall be provided for maintaining the glass temperature within ± 2 °C of a specified temperature.

4.1.5 Temperatures shall be measured with a suitable thermocouple calibrated in accordance with Test Method E220 in conjunction with a calibrated potentiometer or solid state instrumentation capable of 0.5 °C accuracy. An immersion thermocouple is recommended but a thermocouple in air may be used provided measurements show equivalency.

4.1.6 A crucible to contain the glass similar to those shown in Fig. 3 preferably shall be fabricated from a platinum alloy, but a refractory material may be used provided it does not contaminate the glass.

4.1.7 A platinum alloy spindle with the geometry shown in Fig. 4 is recommended. An alternative design has a hollow shaft to house the thermocouple (junction at the center of the large diameter portion) which has the advantage of proximity, but the disadvantage of possible electrical disconnection during torque measurement.

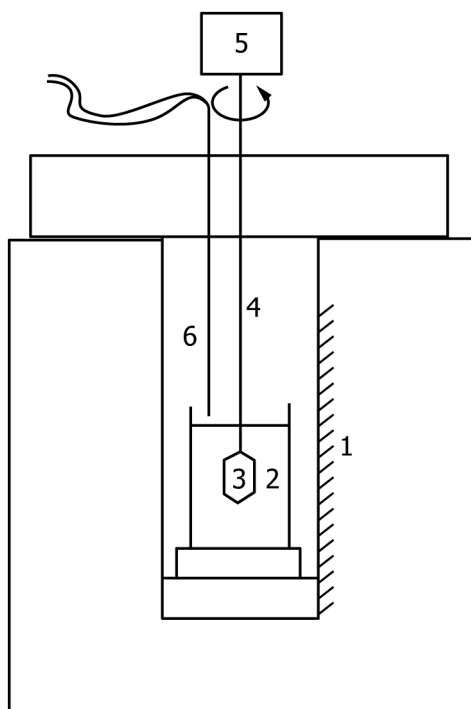

- 1—Furnace Winding
- 2—Crucible
- 3—Spindle
- 4—Shaft
- 5—Viscometer (providing both rotation and torque measurement)
- 6—Thermocouple

FIG. 1 General Arrangement for Rotating Spindle, Fixed Crucible Scheme (Procedure A)

4.1.8 A measurement system is necessary for measurement of spindle torque to an accuracy of 1 %.

5. Preparation of Test Glass

5.1 Select a mass of glass that is free of foreign material. Break or cut glass into pieces, each weighing about 10 g to 50 g, and place the correct quantity into the crucible that will make the molten charge reach a level at some fixed distance (several millimeters) above the point where the spindle narrows down. The weight of glass required can be approximated satisfactorily with the following expression for a cylindrical crucible:

$$W_T = [\pi d^2(L+h)/4 - V_s]\rho (1 - 0.0007\alpha) \quad (1)$$

where:

- h = distance between crucible floor and spindle tip, mm (generally greater than 10 mm to avoid end effects)
- W_T = glass charge weight at room temperature, g,
- d = inside diameter of crucible, mm,
- L = immersed portion of spindle, mm,
- V_s = volume of immersed portion of spindle, mm³,
- ρ = density of glass at room temperature, g/cm³, and
- α = 0 °C to 300 °C thermal expansion coefficient, cm/(cm·°C) ($\times 10^7$).

Avoid very small pieces of glass in the charge as they tend to make the molten glass seedy.

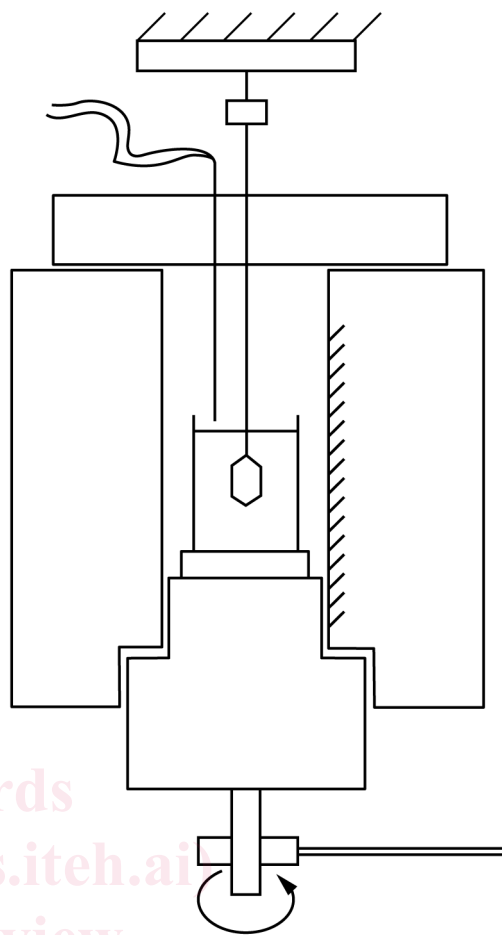

NOTE 1—Details are the same as in Fig. 1 except that the viscometer is replaced by a torque measuring device, and the crucible is mounted on a removable rotatable stand.

FIG. 2 General Apparatus Arrangement for Rotating Crucible Scheme (Procedure B)

5.2 Place the filled crucible in proper position in the furnace and heat to a temperature that lowers the viscosity of glass sufficiently to allow trapped air bubbles to be released. This temperature should be below the original melting temperature to avoid reboil. If reboil occurs, allow additional time for the glass to clear. Hold at this temperature at least 20 min before starting measurements.

6. Calibration and Viscosity Determination

6.1 The use of several standard reference glasses which provide a wide range of temperatures and viscosities for calibration is recommended.

6.2 For constant angular velocity rotation:

$$\eta \propto \Omega/\omega \quad (2)$$

where:

- η = viscosity,
- Ω = torque, and
- ω = angular velocity

For aperiodic return:

$$\eta \propto t/\ln(\theta_2/\theta_1) \quad (3)$$

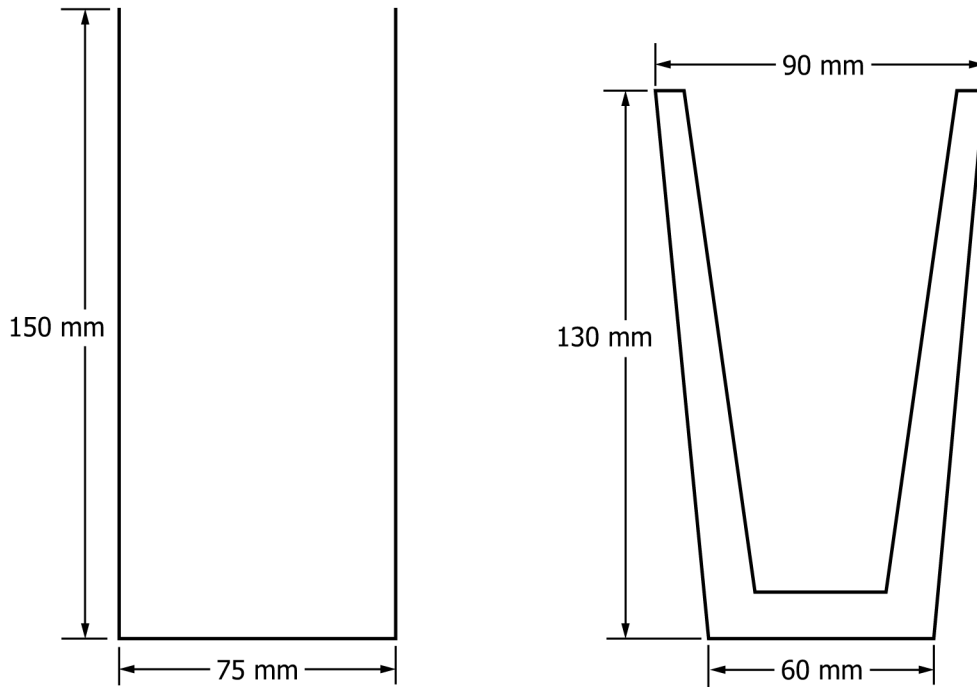

Platinum alloy crucible made from 0.10 to 0.12-cm sheet.

Refractory crucible of suitable composition.

FIG. 3 Two Types of Crucibles

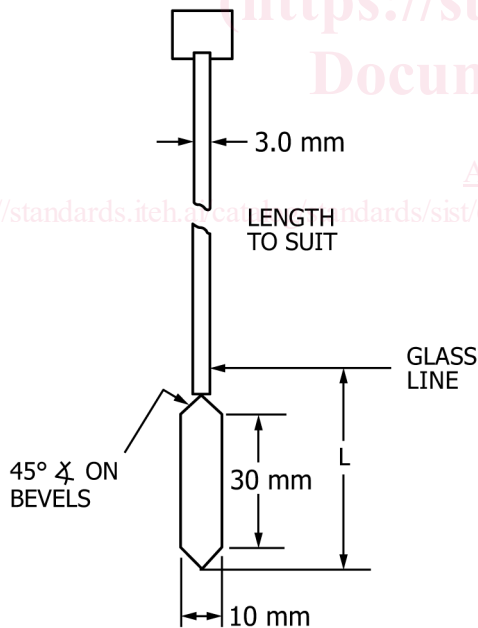

FIG. 4 Typical Platinum Alloy Spindle

plots indicate a problem in the apparatus which must be corrected. These linear plots, once well-established, are used to derive viscosity of unknown test glasses. A linear regression of the calibration data is recommended.

7. Procedure

7.1 Center the spindle over the crucible with a preset fixture that assures concentric alignment and lower the spindle into the molten glass. The displacement between spindle end and crucible floor shall be sufficient to minimize end effects (generally 1 cm or more will suffice). Allow a few minutes for the glass line to stabilize. Connect the torque-measuring system.

7.2 Depending on whether Procedure A or Procedure B is being employed, start rotation of either spindle or crucible. Measure and record the torque after it has stabilized. Measure and record the temperature at the time of torque measurement.

7.3 Adjust the temperature controller to change the temperature for the next set of readings. Allow sufficient time for temperature stabilization, and repeat 7.2. Torque readings may be taken on cooling or heating providing that data so taken are in agreement with steady-state measurements.

7.4 Torque-temperature data are repeated to provide sufficient data to describe the viscosity-temperature relationship.

7.5 With a steel wire suspension as the torque measurement member, viscosities above 10^3 Pa·s require very stiff (large diameter) wire. An alternative to constant angular velocity rotation is to displace the spindle some 30 to 40° from the rest (0°) position and allow the wire suspension to drive the spindle

where:

t = time to traverse θ_2 to θ_1 angular displacement.

6.3 Using the standard reference glasses, establish linear plots of η versus Ω/ω or η versus $t/\ln(\theta_2/\theta_1)$, or both. By proper selection of glasses, the same viscosity can be attained at different temperatures; this can be helpful in establishing whether temperature errors are present. Nonlinearity of these