



Designation: **D7750–12 (Reapproved 2017) D7750 – 23**

Standard Test Method for Cure Behavior of Thermosetting Resins by Dynamic Mechanical Procedures using an Encapsulated Specimen Rheometer¹

This standard is issued under the fixed designation D7750; the number immediately following the designation indicates the year of original adoption or, in the case of revision, the year of last revision. A number in parentheses indicates the year of last reapproval. A superscript epsilon (ϵ) indicates an editorial change since the last revision or reapproval.

1. Scope

1.1 This method covers the use of dynamic mechanical instrumentation for determination and reporting of the thermal advancement of cure behavior of thermosetting resin on an inert filler or fiber in a laboratory. It may also be used for determining the cure properties of ~~filled resins and resins without reinforcements without fillers or fibers~~. These encapsulated specimens are deformed in torsional shear using dynamic mechanical methods.

1.2 This method is intended to provide means for determining the cure behavior of thermosetting resins on fibers over a range of temperatures from room temperature to ~~250°C~~ 250 °C by forced-constant amplitude techniques (in accordance with Practice D4065). Plots of complex modulus, complex viscosity, and damping ratio or tan delta as a function of time or temperature, or both, quantify the thermal advancement or cure characteristics of a resin or a resin on filler or fiber.

1.3 Test data obtained by this method is relevant and appropriate for optimizing cure cycles.

1.4 The values stated in SI units are to be regarded as standard. No other units of measurement are included in this standard.

1.4.1 *Exception*—The ~~fahrenheit~~ Fahrenheit temperature measurement in 10.1 is provided for information only and is not considered standard.

1.5 *This standard does not purport to address all of the safety concerns, if any, associated with its use. It is the responsibility of the user of this standard to establish appropriate ~~safety and health~~ safety, health, and environmental practices and determine the applicability of regulatory limitations prior to use.*

1.6 *This international standard was developed in accordance with internationally recognized principles on standardization established in the Decision on Principles for the Development of International Standards, Guides and Recommendations issued by the World Trade Organization Technical Barriers to Trade (TBT) Committee.*

2. Referenced Documents

2.1 ASTM Standards:²

D3878 [Terminology for Composite Materials](#)

¹ This test method is under the jurisdiction of ASTM Committee D30 on Composite Materials and is the direct responsibility of Subcommittee D30.03 on Constituent/Precursor Properties.

Current edition approved Aug. 1, 2017/April 1, 2023. Published September 2017/May 2023. Originally approved in 2012. Last previous edition approved in 2017 as D7750–12. DOI: 10.1520/D7750-12R17. – 12 (2017). DOI: 10.1520/D7750-23.

² For referenced ASTM standards, visit the ASTM website, www.astm.org, or contact ASTM Customer Service at service@astm.org. For *Annual Book of ASTM Standards* volume information, refer to the standard's Document Summary page on the ASTM website.

D4000 Classification System for Specifying Plastic Materials
 D4065 Practice for Plastics: Dynamic Mechanical Properties: Determination and Report of Procedures
 D4092 Terminology for Plastics: Dynamic Mechanical Properties
 D4473 Test Method for Plastics: Dynamic Mechanical Properties: Cure Behavior
 D6507 Practice for Fiber Reinforcement Orientation Codes for Composite Materials
 D7028 Test Method for Glass Transition Temperature (DMA T_g) of Polymer Matrix Composites by Dynamic Mechanical Analysis (DMA)
 E380 Practice for Use of the International System of Units (SI) (the Modernized Metric System) (Withdrawn 1997)³

3. Terminology

3.1 *Definitions:* For most definitions applicable to this method refer to Terminology [D4092](#).

3.2 *Definitions of Terms Specific to This Standard:*

3.2.1 *Encapsulated Sample Parallel Plate Rheometer*—Dynamic Mechanical Analyzer apparatus that holds the specimen under pressure within a confined cavity. The apparatus is designed to contain the resin within the specimen throughout the progress of the cure.

4. Summary of Test Method

4.1 A small circular specimen is assembled from uncured thermoset resin materials that correspond to a representation of a composite part. This specimen is placed in mechanical oscillation at a fixed frequency at either isothermal conditions, a linear temperature increase or a time-temperature relation simulating a processing condition. The lower plate oscillates and transmits torque from the lower plate through the sample into the upper plate. The resulting torque measured at the upper plate is converted to shear modulus using equations that compensate for the shape and size of the sample. The shear modulus is separated into a component that is in phase with the applied strain or elastic shear modulus and a component that is 90° out of phase with the applied strain or loss shear modulus. The elastic and loss modulus of the specimen are measured as a function of time. During cure, the elastic shear modulus will initially decrease as the temperature is increased due to a decrease in the viscosity of the resin in the sample. When cure occurs in the sample, the elastic shear modulus increases.

5. Significance and Use

5.1 This method provides a simple means of characterizing the cure behavior of a thermosetting resin specimen that is a representation of a composite part. The diameter of the specimen is approximately ~~38 mm~~ 38 mm and the thickness ranges from ~~2.6 to 3.2 mm~~ 2.6 mm to 3.2 mm. This corresponds to a sample volume of approximately ~~33 cm³~~ 4 cm³. The data may be used for quality control, research and development, and verifying the cure within processing equipment including autoclaves.

5.2 Dynamic mechanical testing provides a sensitive method for determining cure characteristics by measuring the elastic and loss moduli as a function of temperature or time, or both. Plots of cure behavior and tan delta of a material provide graphical representation indicative of cure behavior under a specified time-temperature profile. The presence of fibers within the resin may change the dynamic properties measured within a material. However, it is still possible to compare different resins with the same fiber structure and obtain the relative difference due to the resin cure properties.

5.3 This method can be used to assess the following:

5.3.1 Cure behavior, as well as changes as a function of temperature or time, or both,

5.3.2 Processing behavior, as well as changes as a function of temperature or time, or both,

5.3.3 The effects of processing treatments,

5.3.4 Relative resin behavioral properties, including cure behavior, damping and impact resistance,

5.3.5 The effects of reinforcement on ~~cure~~ cure; the reinforcement can be a fiber or a filler,

³ The last approved version of this historical standard is referenced on www.astm.org.

5.3.6 The effects of materials used to bond the resin and reinforcement,

5.3.7 The effect of formulation additives that might affect processability or performance.

5.4 This provides a method to assess the cure properties of a thermosetting resin containing woven fiber or other reinforcing materials.

5.5 This method is valid for a wide range of oscillation frequencies typically from ~~0.002 to 50 Hz~~ 0.002 Hz to 50 Hz.

NOTE 1—It is recommended that low-frequency test conditions, generally ~~1 to 2 Hz~~ 1 Hz to 2 Hz, be used to generate more definitive cure-behavior information. Slower frequencies will miss important cure properties. Faster frequencies will reduce sensitivity to cure.

6. Interferences

6.1 Apparent discrepancies in results may arise when using different experimental conditions. These apparent differences from results observed in another study can usually be reconciled without changing the observed data, by reporting in full (as described in this method) the conditions under which the data were obtained. One essential condition within this method that must be noted is the presence of pressure within the specimen chamber which ensures good precision.

6.2 In many cases, the specimens made with this method will be significantly smaller than the parts in production. It is essential that specimens be made from representative samples of uncured material used to make parts. This will ensure that the data is representative of the part cure.

6.3 The result is a response to the thermal advancement or cure behavior of the resin. The cure behavior is also influenced by the reinforcement and materials used to enhance the bond between the resin and reinforcement. ~~The reinforcement can be a fiber or a filler.~~

6.4 The data will represent the cure of the system at the measured temperature. Parts are often significantly thicker than the specimen. There may be a significant difference between the temperature versus time profile on the inside and the outside of those composite parts. Thermocouples can be used to measure both temperatures during a cure process of a thick part. The measured temperature versus time data can be used to define temperature versus time profiles for dynamic cure specimens using the procedures of this standard. The results can be used to compare the cure response for the inside and the outside of the composite part.

7. Apparatus

7.1 The function of the apparatus is to hold a resin specimen with inert reinforcement, such as fibers, under pressure and yet prevent the escape of resin. Thereby, the ~~fiber~~ reinforcement to resin ratio will remain constant throughout the test. The material acts as the elastic and dissipative element in a mechanically driven oscillatory shear system. This dynamic mechanical instrument operates in torsional shear using one of the following modes for measuring cure behavior:

7.1.1 Forced, constant amplitude, fixed frequency,

7.1.2 Forced, variable amplitude, fixed frequency.

7.2 The apparatus shall consist of the following:

7.2.1 Parallel plates with serrated or radial grooved surfaces. The diameter of the dies shall be ~~40 ± 2 mm~~ 40 mm ± 2 mm. The depth of the grooves shall be limited to ~~1.0 mm~~ 1.0 mm or less to keep a constant ~~fiber~~ reinforcement to resin ratio.

7.2.2 *Encapsulated Specimen Cavity*—The specimen shall be encapsulated by the two parallel plates and a series of mechanical components at the outer plate diameter designed to contain the specimen under pressure without loss of resin. These components shall include an O-ring inserted at the outer diameter of the specimen (Fig. 1). The O-ring meets ASTM International size No. 2-127.

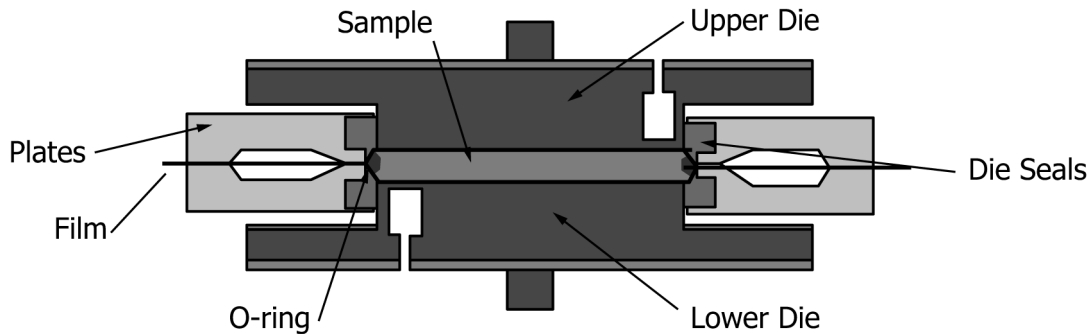

FIG. 1 Encapsulated specimen parallel plate rheometer plate system designed to keep a constant fiberreinforcement to resin ratio during a test.

7.2.3 *Plate Gap*—The thickness of the sample shall range from ~~2.6 to 3.2 mm~~ 2.6 mm to 3.2 mm. The calculation of the sample modulus will include corrections to the actual sample thickness.

7.2.4 *Plate Closing Mechanism*—The system shall apply a pressure of at least ~~4200 kPa~~ 4.2 MPa to the sample to prevent slippage.

7.2.5 *Plate Oscillating System (Strain Device)*—The plate oscillating system shall consist of a direct drive motor that imparts a torsional oscillating movement to the lower plate in the cavity plane. The movement shall produce a continuous oscillatory deformation (strain) on the specimen. The deformation (strain) shall be sinusoidal and shall be applied and released continuously as in a forced-vibration device (see Table 1 of Practice [D4065](#)) to provide a continuous measurement of material state. The preferred amplitude ranges shall be from ± 0.005 ~~0.005°~~ to $\pm 0.060^\circ$. The resulting strain at the nominal specimen thickness will range from ± 0.07 ~~0.07 %~~ to ± 0.8 ~~0.8 %~~.

NOTE 2—The preferred strain for measuring the cure properties of thermoset resins is $\pm 0.7 %$.

7.2.6 *Detectors*—A device or devices for determining dependent and independent experimental parameters, such as torque, frequency, strain amplitude and temperature. Temperature shall be measurable with a precision of ± 0.3 ~~0.3 °C~~ at the outer diameter of the plate, frequency to ± 0.1 ~~0.1 %~~ and torque to ± 0.001 Nm.

7.2.7 *Temperature Controller*—A device for directly heating and cooling the plates with the ability to control the temperature of the plates. The temperature can increase in steps or a linear ramp or cool in steps or a linear ramp. Fig. 2 illustrates a typical time-temperature profile for measuring cure properties. A temperature control system shall be sufficiently stable to permit measurement of plate temperature to within ± 0.3 ~~0.3 °C~~ during heating and ± 1 ~~1 °C~~ during cooling. Fig. 2 also shows that the temperature in the part often deviates from the recommended temperature profile. The apparatus shall process a specimen using either the recommended temperature profile or the actual temperature profile in the part depending on the specification of the test requestor. The report shall contain a comment indicating which type of temperature profile was used.

7.3 The system must have instrument compliance compensation to ensure a good measure for the final modulus values during cure.

8. Sampling and Test Specimens

8.1 The neat resin or the resin with reinforcement should be representative of the polymeric material being tested. If reinforcement is present in the resin, it shall be inert and the dynamic properties of the reinforcement shall not be affected by the temperature used for the dynamic cure test. However, if the presence of reinforcement within the resin may change the dynamic properties measured within a material, it is still possible to compare different resins with the same fiber structure and obtain the relative difference due to the resin cure properties (5.2).

8.2 The recommended specimen diameter for this apparatus is ~~38 ± 0.5 mm~~ 38 mm ± 0.5 mm (Fig. 3) or a diameter recommended by the apparatus manufacturer. Several ~~38-mm~~ 38 mm disks of uncured material shall be laid up to produce a specimen for testing. The reinforcement type and lay-up shall be recorded in accordance with the laminate orientation code of Practice [D6507](#). The number of disks required to produce a specimen will vary with the type of fiber and fiber architecture. A good initial value for the thickness before compressing the sample is 4 mm. The final cured specimen should have a thickness of ~~2-6~~

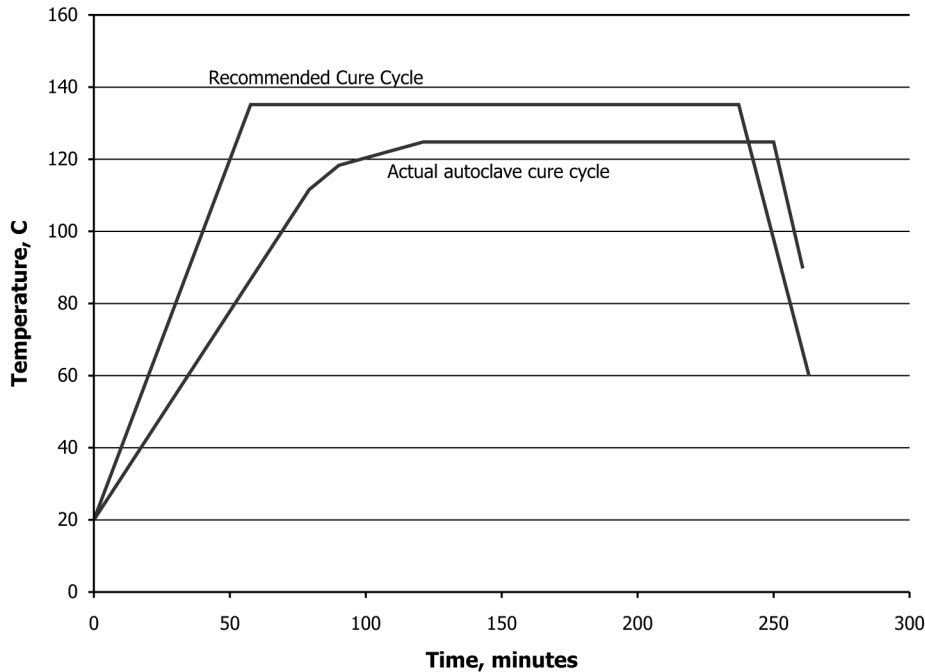

NOTE 1—There is often a discrepancy between the typical temperature program profile and the actual temperature.

FIG. 2 Typical temperature program profile to cure components and the actual temperature at the component.



FIG. 3 Use a circular cutting die to cut 38 mm disks 38 mm disk specimens cut from a sheet of material material using a circular cutting die.

to 3.2 mm 2.6 mm to 3.2 mm after a test is complete. The apparatus will often compress or reduce the initial thickness into the preferred range of a tested specimen. The number of disks may vary with the resin and fiber present in a specimen. The weight of the specimen can be used in place of the thickness as an alternate method to ensure that the final specimen has the preferred thickness at the end of a test. The weight will have to be determined for each resin/fiber combination. In all cases, equal weight or thickness should be used when comparisons are made.

8.3 An elastomeric O-ring shall be placed at the outer diameter of the specimen to help prevent the loss of resin during a test. The specimen shall also be placed between two sheets of release film to eliminate or reduce clean up cleanup after a test. The film prevents the contamination of the plate surface with resins or other materials that can diffuse out of the specimen. The film must be capable of the applied temperature profile temperature. Different films can be used at different temperature ranges.

8.4 Low viscosity neat resins can be measured under pressure either with or without reinforcement.

8.5 A valid result is obtained when the elastomeric O-ring remains intact at the outer diameter of the specimen and the cured sample thickness is within the acceptable range. Also, any shape imparted by the plate surface such as grooves must match the corresponding shape on the cured specimen.

9. Calibration and Standardization

9.1 Torque calibration shall be performed in accordance with apparatus manufacturer’s recommendations.

9.1.1 Calibrate the torque measurement system of the apparatus whenever the plate seals are changed.

9.1.2 *Torque Calibration Procedure*—A reference torque device is required to calibrate the torque measuring system (Fig. 4). The torque standard is inserted between the oscillating and the measuring plate. The reference values for angular displacement and the corresponding torque shall be established by the manufacturer of the apparatus for each torque standard.

9.2 Temperature accuracy of the plates shall be verified using the apparatus manufacturer’s recommendations.

10. Conditioning

10.1 Store the uncured resin or prepreg material at low temperatures, approximately -18°C (0°F)– 18°C (0°F) or in accordance with the material manufacturer’s instructions, to prolong the usefulness of the material. If the test is designed to simulate the cure of material in a manufactured part, then the material should be treated in a similar manner as for the corresponding composite parts. This includes the same date of manufacture, date of the test, and time out of refrigerated storage before lay up. Record both all those items for the test report. Cold material samples taken from a refrigerator or freezer must be kept in a sealed container until the material warms up to the ambient temperature in order to prevent the condensation of moisture on the sample.

11. Procedure

11.1 Parameters to be specified prior to test:

11.1.1 Material storage conditions and time out of cold storage prior to test.

11.1.2 Number of layers of material for the specimen and the layup orientation for each layer.

11.1.3 Test temperature profile.

11.1.4 Strain amplitude start and end values.

11.1.5 Whether post-cure T_g measurement is required, and if so, the desired temperature ramp rate.

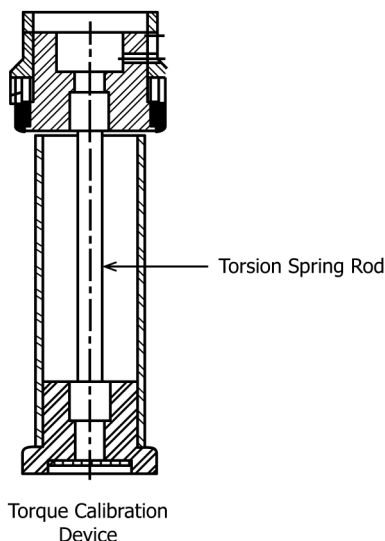

NOTE 1—Device is inserted between the plates when they are in the open position and the device is fastened to the upper and lower plates.

FIG. 4 Typical Torque Standard torque calibration device used to calibrate the torque measurement system in an encapsulated specimen parallel plate rheometer.

11.2 General Instructions:

11.2.1 Ensure that the system contains the correct temperature profile and the instrument plate temperatures have stabilized. Start temperatures less than 40°C should be within $\pm 2^\circ\text{C}$ while temperatures above 40°C should be within $\pm 0.5^\circ\text{C}$.

11.2.2 Set the strain amplitude for the apparatus.

11.2.2.1 The recommended strain amplitude for a specimen that contains fibers reinforcement is 0.7 %.

11.2.2.2 The recommended strain amplitude for a neat resin specimen is in the range of 0.7 % to 10 %, using a controlled stress mode. The test will begin at the highest strain and will automatically reduce the strain on the sample to the lowest strain to prevent the mechanical breakdown of the polymeric structure as it is being developed through polymerization or cross-linking.

11.2.3 Place a sample on a sheet of protective film, such as PTFE film. Place an O-ring at the outer diameter of the sample. Add a second sheet of protective film on top of the sample.

11.2.4 Separate the plates to load the sample. Carefully center the specimen on the lower plate ensuring that the O-ring will not be crushed when the upper plate is lowered.

11.2.5 Bring the plates together to start the test.

11.2.6 At the end of the test, remove the specimen. Measure the thickness and adjust any calculations of modulus for variations in the sample thickness. See equations for forced torsional oscillations at fixed amplitude and frequency in Table 1 of Practice **D4065**.

NOTE 3—Recommended removal of a specimen from the metal plates is at elevated temperatures near the glass transition temperature.

11.3 One procedure used to verify the final cure state of the specimen is to measure the Glass Transition Temperature glass transition temperature or T_g of the specimen after cure. This optional measurement must be done before the pressure on the sample from the apparatus is released at the end of a cure test. The test for the glass transition temperature shall be performed as follows:

11.3.1 Bring the temperature of the specimen to the range of 40 to 50°C 40 °C to 50 °C.

11.3.2 Linearly ramp the temperature to a temperature above the expected T_g or the upper temperature limit of the specimen or apparatus, or both, at a rate between 2°C/min 2 °C/min and 10°C/min 10 °C/min. The preferred oscillation frequency during the Glass Transition measurement glass transition temperature is 1 Hz.

NOTE 4—Slower linear temperature ramp rates of 2°C/min 2 °C/min to 5°C/min 5 °C/min will improve the accuracy and precision of the measurement.

12. Calculation or Interpretation of Results

12.1 The equations listed in Practice **D4065** **D4065** are used to calculate the following important properties:

12.1.1 Storage (elastic) modulus in shear, G' ,

12.1.2 Loss (viscous) modulus in shear, G'' ,

12.1.3 Tan delta,

12.1.4 Complex modulus in shear, G^* .

12.2 The complex viscosity, η^* is calculated from G^*/ω , where ω is the frequency of oscillation in radians/second and G^* is the complex shear modulus.

12.3 The modulus and viscosity can be plotted as a function of either temperature or time. The test for cure behavior is plotted