



Standard Specification for Chocks, Panama, Mooring Cast Steel¹

This standard is issued under the fixed designation F2935; the number immediately following the designation indicates the year of original adoption or, in the case of revision, the year of last revision. A number in parentheses indicates the year of last reapproval. A superscript epsilon (ϵ) indicates an editorial change since the last revision or reapproval.

^{ε1} NOTE—Keywords section was editorially added in March 2018.

1. Scope

- 1.1 This specification covers the principal dimensions and materials of chocks installed in ships to comply with the regulations of the Panama Canal.
- 1.2 Chocks can be used with either wire rope or fiber and synthetic ropes.
- 1.3 Chocks are for mounting directly on a deck, seat (foundation) or for mounting in a bulwark.
- 1.4 To meet Panama Canal Company regulations the radius of contact surfaces of lines must be 180 mm.
- 1.5 The values stated in SI units are to be regarded as standard. No other units of measurement are included in this standard.
- 1.6 *This international standard was developed in accordance with internationally recognized principles on standardization established in the Decision on Principles for the Development of International Standards, Guides and Recommendations issued by the World Trade Organization Technical Barriers to Trade (TBT) Committee.*

2. Referenced Documents

- 2.1 *ASTM Standards:*²
 - [A27/A27M Specification for Steel Castings, Carbon, for General Application](#)
- 2.2 *ANSI Standards:*³
 - [B 46.1 Surface Texture \(Roughness, Waviness, Lay\)](#)

3. Terminology

3.1 *Definitions of Terms Specific to This Standard:*

- 3.1.1 *bulwark*—a structural enclosure along the edge of the ship to serve as a rail.
- 3.1.2 *closed chock*—a metal flared ring-like fitting mounted on a ship through which mooring lines pass to tow or moor a ship.

¹ This specification is under the jurisdiction of ASTM Committee F25 on Ships and Marine Technology and is the direct responsibility of Subcommittee F25.01 on Structures.

Current edition approved March 1, 2018; May 1, 2023. Published April 2018; May 2023. Originally approved in 2012. Last previous edition approved in 2012 as F2935 – 12. DOI:10.1520/F2935-12R18E01-12 (2018)^{ε1}. DOI:10.1520/F2935-23.

² For referenced ASTM standards, visit the ASTM website, www.astm.org, or contact ASTM Customer Service at service@astm.org. For *Annual Book of ASTM Standards* volume information, refer to the standard's Document Summary page on the ASTM website.

³ Available from American National Standards Institute (ANSI), 25 W. 43rd St., 4th Floor, New York, NY 10036, <http://www.ansi.org>.

3.1.3 *mooring ring or pipe*—a chock mounted in the bulwark and conforming to Type II or IV.

3.1.4 *rope contact area*—that part of the fitting in contact with the mooring line in normal mooring operations.

4. Classification

4.1 The size of the chock shall be identified by the nominal size “L” and “H” of the opening as shown in [Table 1](#) and [Fig. 1](#), and [Table 2](#) and [Fig. 2](#). Sizes larger than 360 mm by 260 mm may be considered as double chocks.

4.2 Chocks are furnished in types as follows:

4.2.1 *Type I*—Deck mounted, as shown in [Fig. 1](#), and conforms to all dimensions in [Table 1](#).

4.2.2 *Type II*—Bulwark mounted, as shown in [Fig. 2](#), and conforms to all dimensions in [Table 2](#).

4.2.3 *Type III*—Deck mounted conforming only to dimensions “L”, “H”, and 180 mm radius at entrance, as shown in [Fig. 1](#) and [Table 1](#) and the requirements of Sections [6–10](#).

4.2.4 *Type IV*—Bulwark mounted conforming only to dimensions “L”, “H”, and 180 mm radius at entrance, as shown in [Fig. 2](#) and [Table 2](#) and the requirements of Sections [6 to 10](#).

4.3 Chocks shall be furnished in either of the following grades:

4.3.1 *Grade 1*—Surface finish shall be in the as cast condition.

4.3.2 *Grade 2*—Surface finish in way of rope contact shall be in accordance with [7.2](#).

5. Ordering Information

5.1 Orders for chocks under this specification shall include this standard date, and the following:

5.1.1 Quantity (number) of chocks required,

5.1.2 Size (opening, $L \times H$),

5.1.3 Type and grade,

5.1.4 Primer and coating, if any (see [7.3](#)), and

5.1.5 Marking.

6. Materials and Manufacture

6.1 Material shall be cast steel in accordance with Specification [A27/A27M](#), Grade 60–30.

6.2 For Types III and IV the manufacturer shall certify that chock is in compliance with Panama Canal requirements.

TABLE 1 Dimension Requirements (see [Fig. 1](#))
(Unit: mm)

Nominal size	L	l_1	l_2	l_3	l_4	H	H_1	H_2	R	R_1	R_2
310	310	708	688	105	310	260	639	543	130	329	233
360	360	760	740	130	360	260	640	545	130	330	235
Nominal size	R_3	R_4	R_5	T	D	Welding leg length		SWL		Calculated weight (kg)	
						z_1		kN	tonnes		
310	142	140	195	32	38	8		471	48		257
360	140	138	192	34	40	8.5		687	70		286

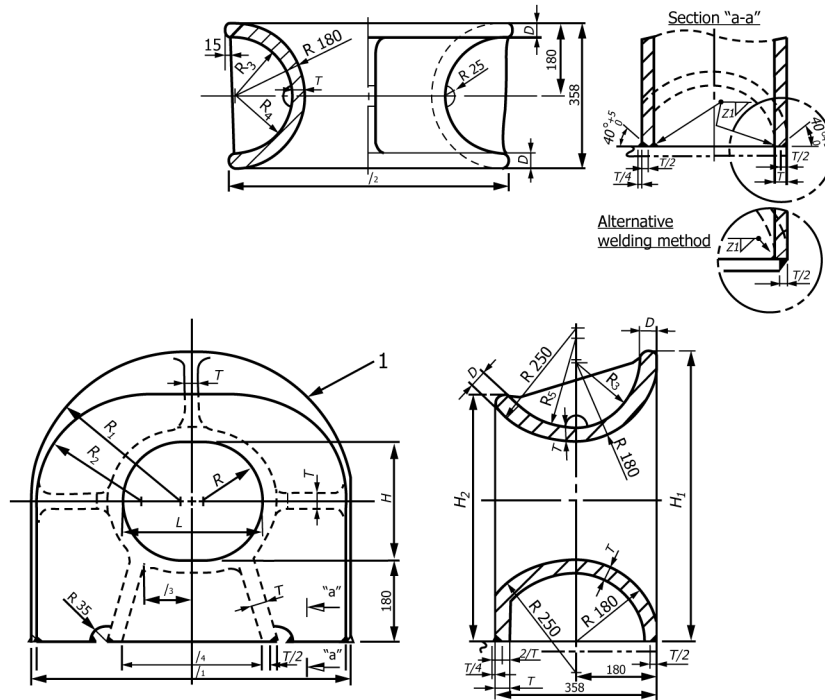

NOTE 1—All fillet radii to be equal to “T”.

NOTE 2—All final products must have a thickness no less than “T”.

FIG. 1 Configuration of Deck Mounted Chocks

TABLE 2 Dimension Requirements (see Fig. 2)
(Unit: mm)

Nominal size	L	l_1	l_2	H	H_1	H_2	R	R_1	R_2	R_3	R_4
310	310	720	688	260	670	453	130	335	227	149	147
360	360	770	733	260	670	456	130	335	228.5	147	145
Nominal size	R_5	T	D_1	θ	—	Welding leg length	z_1	z_2	SWL	—	Calculated weight (kg)
310	205	25	31	44°	—	12.5	10	726	70	—	228
360	203	27	33	43°	—	13.5	11	814	79	—	248

6.3 Casting shall be smooth, fine grain, and free of cracks, hot tears, and blow holes, detrimental to end use. Defects having an area larger than 25 by 25 mm² and a depth of more than 10 % of the thickness in way thereof will be cause for rejection. Small defects in way of rope contact shall be welded and finished smooth. Where applicable, welding shall be in accordance with code requirements, such as ABS, AWS, and so on, and may require post weld heat treatment (PWHT).

6.4 All excess material, vents, and gates shall be removed and finished smooth to match the surrounding surface.

6.5 Limber or drain holes shall be 25 mm in diameter and provided in webs and brackets to prevent water entrapment.

6.6 Type I shall be in accordance with Fig. 1 and Table 1.

6.7 Type II shall be in accordance with Fig. 2 and Table 2.

7. Workmanship, Finish, and Appearance

7.1 Casting shall be sand, grit, or shot blasted to a gray metal finish to remove all loose scale. All mold flashing shall be removed and radii shall be fair so as to present an even surface.