



Designation: C1229 – 94 (Reapproved 2023)

Standard Test Method for Determination of Glass Fiber Content in Glass Fiber Reinforced Concrete (GFRC) (Wash-Out Test)¹

This standard is issued under the fixed designation C1229; the number immediately following the designation indicates the year of original adoption or, in the case of revision, the year of last revision. A number in parentheses indicates the year of last reapproval. A superscript epsilon (ϵ) indicates an editorial change since the last revision or reapproval.

1. Scope

1.1 This test method covers determination of the fiber content in an uncured, glass fiber reinforced concrete (GFRC) sample panel.

1.2 The values stated in inch-pound units are to be regarded as standard. The values given in parentheses are mathematical conversions to SI units that are provided for information only and are not considered standard.

1.3 *This standard does not purport to address all of the safety concerns, if any, associated with its use. It is the responsibility of the user of this standard to establish appropriate safety, health, and environmental practices and determine the applicability of regulatory limitations prior to use.*

1.4 *This international standard was developed in accordance with internationally recognized principles on standardization established in the Decision on Principles for the Development of International Standards, Guides and Recommendations issued by the World Trade Organization Technical Barriers to Trade (TBT) Committee.*

2. Referenced Documents

2.1 *ASTM Standards:*²

C1228 Practice for Preparing Coupons for Flexural and Washout Tests on Glass Fiber Reinforced Concrete

3. Terminology

3.1 *Definitions:*

3.1.1 *glass fiber reinforced concrete (GFRC)*—a composition of cementitious material, aggregates, water, admixtures, and alkali-resistant glass fiber.

¹ This test method is under the jurisdiction of ASTM Committee C27 on Precast Concrete Products and is the direct responsibility of Subcommittee C27.40 on Glass Fiber Reinforced Concrete.

Current edition approved May 1, 2023. Published May 2023. Originally approved in 1993. Last previous edition approved in 2015 as C1229 – 94(2015). DOI: 10.1520/C1229-94R23.

² For referenced ASTM standards, visit the ASTM website, www.astm.org, or contact ASTM Customer Service at service@astm.org. For *Annual Book of ASTM Standards* volume information, refer to the standard's Document Summary page on the ASTM website.

4. Significance and Use

4.1 Glass fiber contents, determined by this test method, are useful for quality control of GFRC products to ensure that manufacturing equipment has been set up to deliver the correct proportions of glass fiber reinforcement in a GFRC composite.

5. Apparatus

5.1 *Balance*, 2 kg capacity, sensitive to the nearest 0.1 g.

5.2 *Mesh Basket or Strainer*, approximately 30 in.³ (493 cm³) capacity of woven stainless steel wire and mesh size between $\frac{3}{16}$ (4.5 mm) and $\frac{1}{16}$ (1.5 mm). Overall dimensions must totally accept the test sample without any overhang, and depth should be approximately twice the thickness of the test sample. Gage and construction must be such that mesh dimension cannot easily enlarge, allowing glass reinforcement to escape.

5.3 *Drying Chamber*, an oven that can be set at $230 \pm 10^\circ\text{F}$ ($110 \pm 10^\circ\text{C}$), or a muffle furnace set at $900 \pm 10^\circ\text{F}$ ($482 \pm 10^\circ\text{C}$).

5.4 *Razor Knife*, capable of 6 in. blade extension.

5.5 *Splitting Jig*, see Fig. 1.

6. Sampling

6.1 Sampling should be in accordance with governing specifications.

7. Test Specimens

7.1 Cut the coupons with a razor knife from a freshly cast, damp, uncured sample panel. When cutting out the test coupon, the sample panel shall have sufficient cohesiveness such that: (a) a clean cut can be made without pulling out fibers from the test coupon or the adjacent material, and (b) that material is not lost from the test coupon prior to determining mass.

7.2 The test specimen shall be between 12 in.² (78 cm²) and 16 in.² (103 cm²).

8. Procedure

8.1 Cut two test coupons with a razor knife from a freshly produced, damp, uncured sample panel as done in Practice C1228. Place the coupons in a mesh basket of known mass

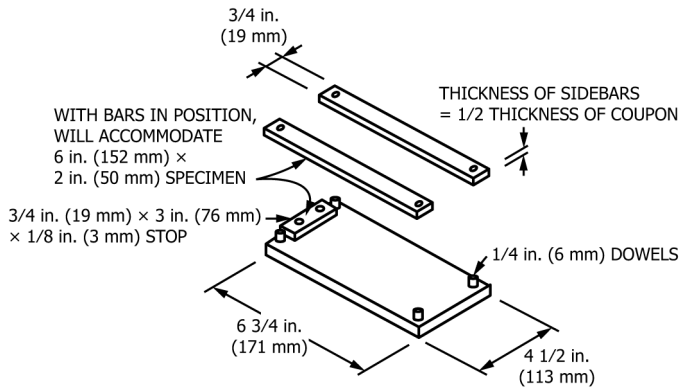

FIG. 1 Splitting Jig

(W 1) and record the total mass (W2). The basket and contents are held under a stream of running water and the composite is worked with fingers to break it up. Take care to ensure that no glass is lost. See Fig. 2.

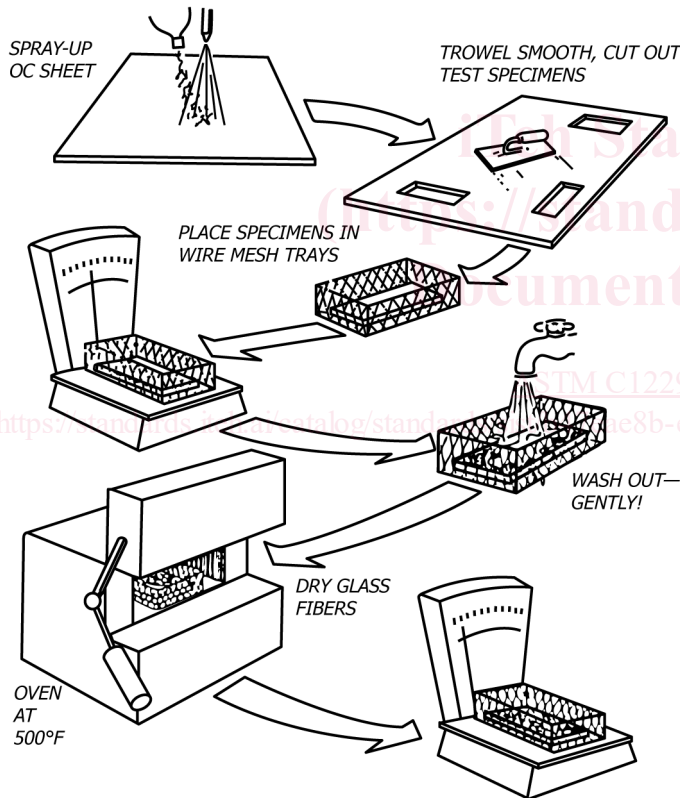

FIG. 2 Procedure for Determination of Glass Fiber Content

8.2 When all the cement and fine aggregate (if any) are washed away, dry the basket and contents in an oven at $230 \pm 10^\circ\text{F}$ ($110 \pm 10^\circ\text{C}$), (or muffle furnace at $900 \pm 10^\circ\text{F}$ ($483 \pm 10^\circ\text{C}$) to a constant mass, as determined by taking three measurements at 10 min intervals. After drying, tap the basket of dried glass against the countertop to dislodge adhered sand particles that would induce an error in the glass content measurement. Be careful not to lose any glass particles. The last value of mass is recorded as W3, provided it differs from the previous value by less than 0.1 %.

NOTE 1—Microwave ovens should not be used to dry glass fiber.

NOTE 2—If desired or required, a measure of the glass fiber distribution through the thickness of the coupon can be obtained by repeating the procedure on coupons slit into two halves through the thickness using the splitting jig as shown in Fig. 1. If this is done, the two halves should have approximately equal mass.

8.3 Record the final value of mass as W 3, provided it differs from the previous weight measurement by less than 0.1 %.

9. Calculations

9.1 Glass fiber content in a washout coupon is calculated as follows:

$$\text{glass fiber content} = \frac{W3 - W1}{W2 - W1} \times 100 \quad (1)$$

where:

W1 = mass of basket, g,

W2 = mass of basket plus coupon, g, and

W3 = mass of basket plus glass (after drying), g.

Record mass change to the nearest 0.1 percent of original mass.

NOTE 3—If the procedure in Note 2 is followed, the glass fiber distribution through the thickness can be calculated by measuring the glass fiber contents in the two split halves and expressing them (to the nearest 0.1) as a top to bottom ratio.

Top to bottom ratio (2)

$$= \frac{\text{glass fiber content in top, \%}}{\text{glass fiber content in the bottom, \%}}$$

10. Precision and Bias

10.1 Precision—The precision of this test method is being determined.

10.2 Bias—Since there is no accepted reference material, the bias of this test method cannot be determined.

11. Keywords

11.1 glass fiber; glass fiber reinforced concrete (GFRC); wash-out test