



Designation: D1623 – 17 (Reapproved 2023)

# Standard Test Method for Tensile and Tensile Adhesion Properties of Rigid Cellular Plastics<sup>1</sup>

This standard is issued under the fixed designation D1623; the number immediately following the designation indicates the year of original adoption or, in the case of revision, the year of last revision. A number in parentheses indicates the year of last reapproval. A superscript epsilon ( $\epsilon$ ) indicates an editorial change since the last revision or reapproval.

*This standard has been approved for use by agencies of the U.S. Department of Defense.*

## 1. Scope

1.1 This test method covers the determination of the tensile and tensile adhesion properties of rigid cellular materials in the form of test specimens of standard shape under defined conditions of temperature, humidity, and testing machine speed.

1.2 Tensile properties shall be measured using any of three types of specimens:

1.2.1 *Type A* shall be the preferred specimen in those cases where enough sample material exists to form the necessary specimen.

1.2.2 *Type B* shall be the preferred specimen when only smaller specimens are available, as in sandwich panels, etc.

1.2.3 *Type C* shall be the preferred specimen for the determination of tensile adhesive properties of a cellular plastic to a substrate as in a sandwich panel (top and bottom substrate) or the bonding strength of a cellular plastic to a single substrate.

1.3 The values stated in SI units are to be regarded as standard. The values given in parentheses are mathematical conversions to inch-pound units that are provided for information only and are not considered standard.

NOTE 1—There is no known ISO equivalent to this test method.

1.4 *This international standard was developed in accordance with internationally recognized principles on standardization established in the Decision on Principles for the Development of International Standards, Guides and Recommendations issued by the World Trade Organization Technical Barriers to Trade (TBT) Committee.*

<sup>1</sup> This test method is under the jurisdiction of ASTM Committee D20 on Plastics and is the direct responsibility of Subcommittee D20.22 on Cellular Materials - Plastics and Elastomers.

Current edition approved May 1, 2023. Published May 2023. Originally approved in 1959. Last previous edition approved in 2017 as D1623 – 17. DOI: 10.1520/D1623-17R23.

## 2. Referenced Documents

2.1 *ASTM Standards:*<sup>2</sup>

D638 Test Method for Tensile Properties of Plastics

D883 Terminology Relating to Plastics

E691 Practice for Conducting an Interlaboratory Study to Determine the Precision of a Test Method

## 3. Terminology

3.1 Definitions of terms applying to this test method appear in Test Method D638, Annex A2.

## 4. Apparatus

4.1 *Testing Machine*—A testing machine that is capable of applying a constant rate of crosshead movement, comprising essentially the following:

4.1.1 *Grips*—Grips for holding the test specimen shall be the self-aligning type; that is, they must be attached to the fixed and movable members of the testing machine in such a way that they will move freely into alignment as soon as any load is applied, so that the long axis of the test specimen will coincide with the direction of the applied pull through the center line of the grip assembly. Universal-type joints immediately above and below the specimen grips are recommended. The test specimen shall be held in such a way that slippage relative to the grips is prevented, insofar as possible. For Type A specimens, use a grip assembly like the one shown in Fig. 1 and Fig. 2. For Type B specimens, one suitable grip assembly is shown in Fig. 3 and Fig. 4. For Type C specimen, a suitable grip assembly is shown in Fig. 5.

4.1.2 *Load Indicator*—A load cell or suitable load-indicating mechanism, capable of showing the total tensile load

<sup>2</sup> For referenced ASTM standards, visit the ASTM website, www.astm.org, or contact ASTM Customer Service at service@astm.org. For *Annual Book of ASTM Standards* volume information, refer to the standard's Document Summary page on the ASTM website.

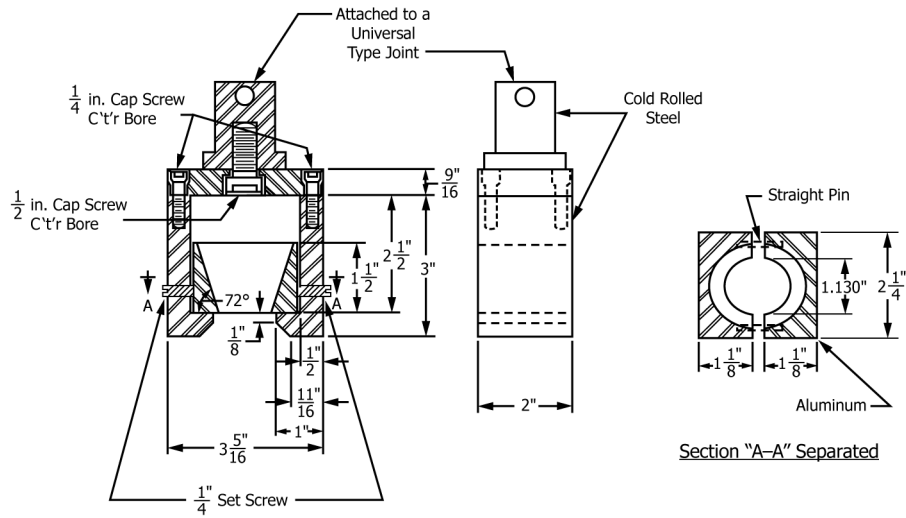

Metric Equivalents

in.	1/8	1/4	1/2	9/16	11/16	1	1.130	1 1/2	2	2 1/4	2 1/2	3	3 5/16
mm	3.18	6.35	12.7	14.3	17.5	25.4	28.7	38.1	50.8	57.2	63.5	76.2	84.1

FIG. 1 Details of Grips for Tension Test on Type A Specimen

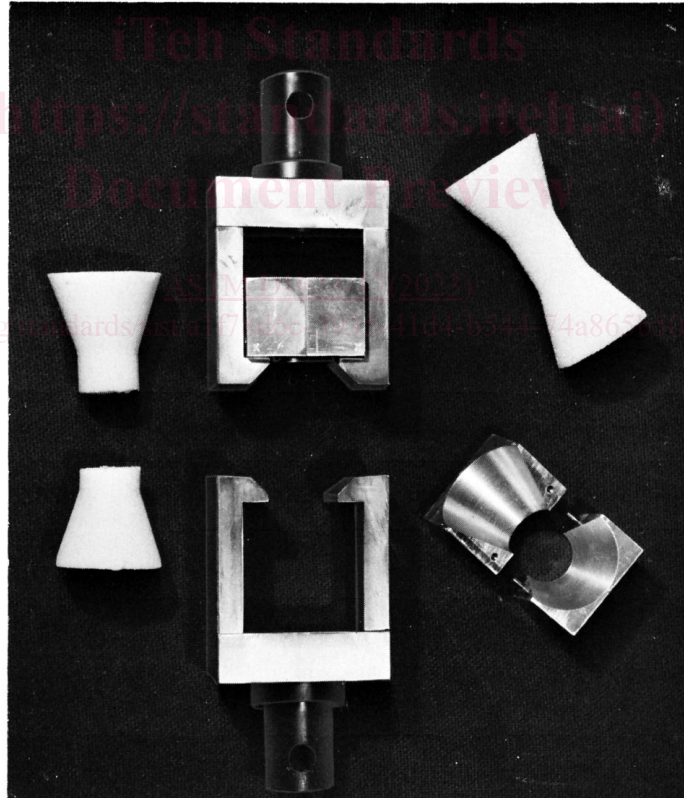
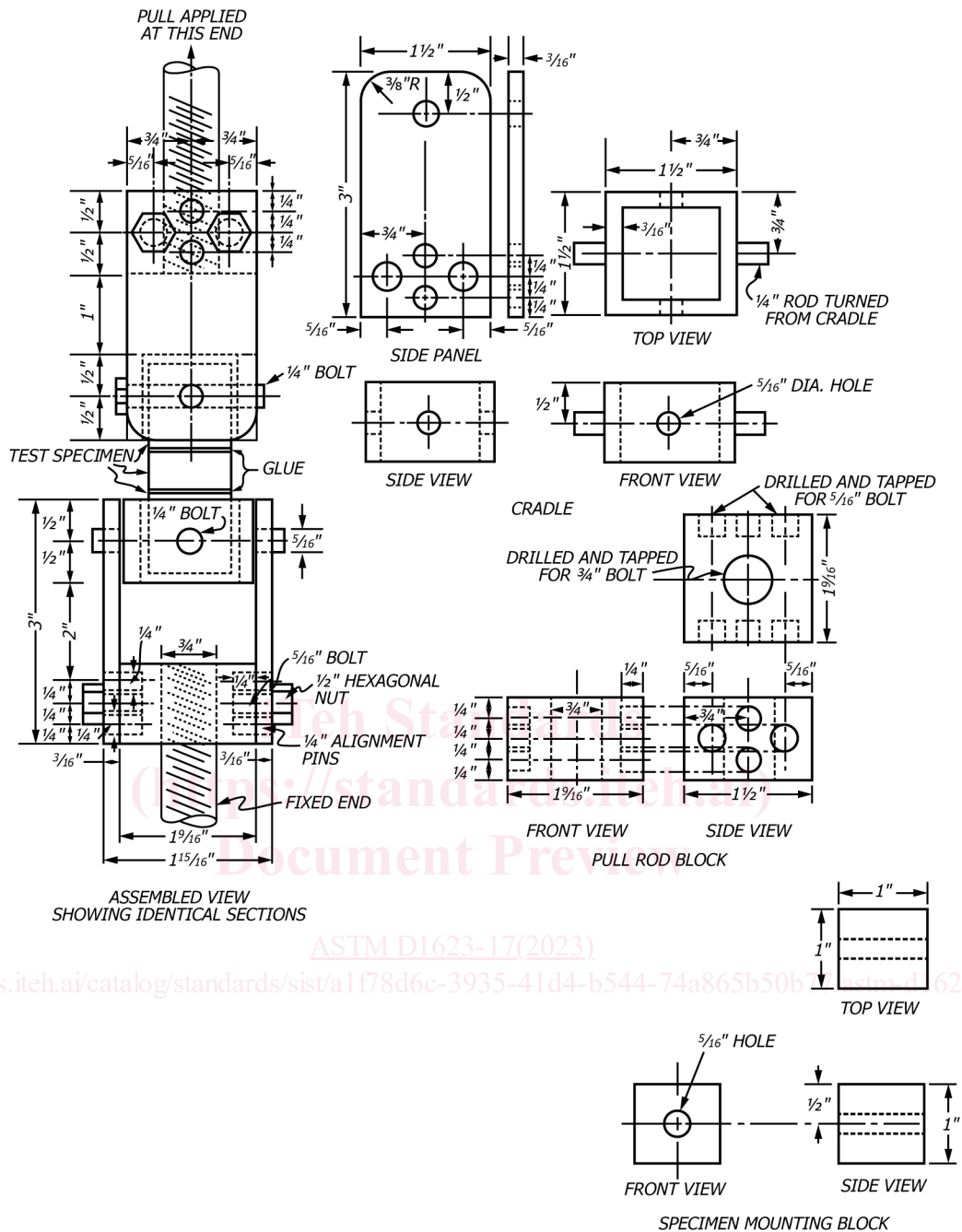

FIG. 2 Grip Assembly for Type A Specimen

exerted on the test specimen when held in the grips, shall be used. Choose an indicator that will permit precision to within  $\pm 1\%$ .



ASTM D1623-17(2023)  
<https://standards.iteh.ai/catalog/standards/sist/a1f78d6c-3935-41d4-b544-74a865b50b/astm-d1623-17-2023>

Metric Equivalents

in.	3/16	1/4	1/2	5/16	3/4	1	1 1/2	1 9/16	2	3
mm	4.76	6.35	12.7	7.9	19.1	25.4	38.1	39.7	50.8	76.2

FIG. 3 Details of Grips for Tension on Type B Specimen

4.1.3 *Extension Indicator*—If measurement of the extension is desired, a suitable instrument for determining the distance between two fixed points on the test specimen, or similarly by grip separation or extensometer, at any time during the test, shall be used.

4.2 *Specimen Cutter*—For Type A specimens, use a suitable lathe cutter (see Fig. 6).

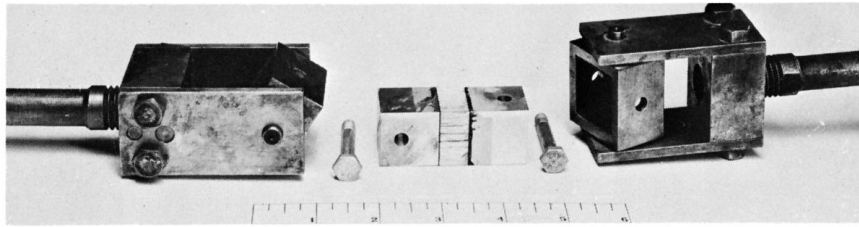

FIG. 4 Grip Assembly for Type B Specimen

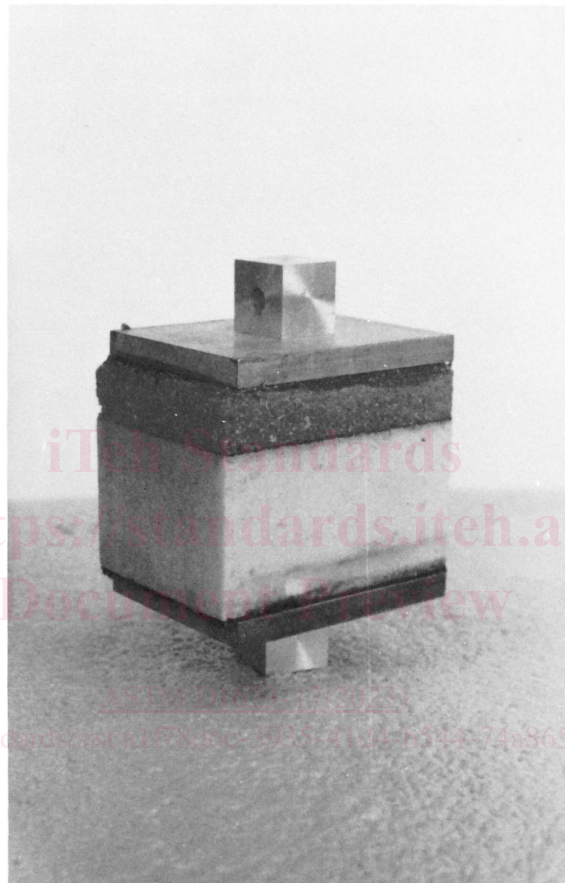

FIG. 5 Grip Assembly for Type C Specimen

**5. Test Specimen**

5.1 All surfaces of the specimen shall be free of large visible flaws or imperfections. If it is necessary to place gauge marks on the specimen, do this in such a way as not to affect the surfaces of the test specimen. Gauge marks shall not be scratched, punched, or impressed on the specimen.

5.2 When testing materials that are suspected to be anisotropic, prepare duplicate sets of specimens having their long axes parallel and perpendicular to the direction of the cell orientation.

5.3 *Preparation of Type A Specimens*—The recommended Type A test specimen shall conform to the dimensions given in Fig. 7. It shall be prepared by normal molding procedures wherever possible, but the “skin” effect which results cannot be eliminated and will cause a variance in the final result. Another

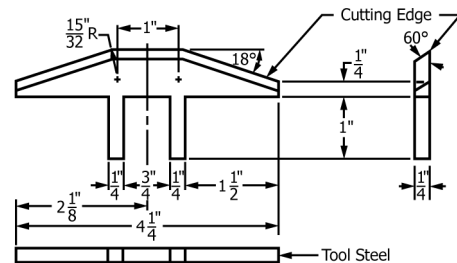

		Metric Equivalents					
in.	1/4	19/32	3/4	1 1/2	2 1/8	4 1/4	
mm	6.35	11.9	19.1	38.1	54.0	108.0	

FIG. 6 Cutter for Preparing Type A Specimen