



Designation: ~~D611–12 (Reapproved 2016)~~ D611 – 23



Designation: 2/98 (2014)

Standard Test Methods for Aniline Point and Mixed Aniline Point of Petroleum Products and Hydrocarbon Solvents^{1,2}

This standard is issued under the fixed designation D611; the number immediately following the designation indicates the year of original adoption or, in the case of revision, the year of last revision. A number in parentheses indicates the year of last reapproval. A superscript epsilon (ϵ) indicates an editorial change since the last revision or reapproval.

This standard has been approved for use by agencies of the U.S. Department of Defense.

1. ~~Scope~~ Scope*

1.1 These test methods cover the determination of the aniline point of petroleum products and hydrocarbon solvents. Test Method A is suitable for transparent samples with an initial boiling point above room temperature and where the aniline point is below the bubble point and above the solidification point of the aniline-sample mixture. Test Method B, a thin-film method, is suitable for samples too dark for testing by Test Method A. Test Methods C and D are for samples that may vaporize appreciably at the aniline point. Test Method D is particularly suitable where only small quantities of sample are available. Test Method E describes a procedure using an automatic apparatus suitable for the range covered by Test Methods A and B.

1.2 These test methods also cover the determination of the mixed aniline point of petroleum products and hydrocarbon solvents having aniline points below the temperature at which aniline will crystallize from the aniline-sample mixture.

1.3 The values stated in SI units are to be regarded as standard. No other units of measurement are included in this standard.

1.4 **WARNING**—Mercury has been designated by many regulatory agencies as a hazardous ~~material~~ substance that can cause ~~central nervous system, kidney and liver damage, serious medical issues.~~ Mercury, or its vapor, ~~may~~ has been demonstrated to be hazardous to health and corrosive to materials. ~~Caution should be taken—Use caution when handling mercury and mercury containing mercury-containing products.~~ See the applicable product Material Safety Data Sheet (MSDS) for details and EPA's website ~~—http://www.epa.gov/mercury/faq.htm—~~ for additional information. ~~Users should be aware—(SDS) for additional information.~~ The potential exists that selling mercury ~~and/or mercury-containing products into your state or country may be prohibited by law or mercury-containing products, or both, is prohibited by local or national law.~~ Users must determine legality of sales in their location.

1.5 *This standard does not purport to address all of the safety concerns, if any, associated with its use. It is the responsibility of the user of this standard to establish appropriate ~~safety and health~~ safety, health, and environmental practices and determine the applicability of regulatory limitations prior to use.* Specific warning statements are given in Section 7.

¹ These test methods are under the jurisdiction of ASTM International Committee D02 on Petroleum Products, Liquid Fuels, and Lubricants and are the direct responsibility of ASTM Subcommittee D02.04.0D on Physical and Chemical Methods. The technically equivalent standard as referenced is under the jurisdiction of the Energy Institute Subcommittee SC-B-10.

Current edition approved Oct. 1, 2016 May 1, 2023. Published November 2016 May 2023. Originally approved in 1941. Last previous edition approved in 2012 2016 as ~~D611–12~~ D611 – 12 (2016). DOI: ~~40.1520/D0611-12R16~~ 10.1520/D0611-23.

These test methods were adopted as a joint ASTM-IP standard in 1964.

² This test method has been developed through the cooperative effort between ASTM and the Energy Institute, London. ASTM and IP standards were approved by ASTM and EI technical committees as being technically equivalent but that does not imply both standards are identical.

*A Summary of Changes section appears at the end of this standard

1.6 This international standard was developed in accordance with internationally recognized principles on standardization established in the Decision on Principles for the Development of International Standards, Guides and Recommendations issued by the World Trade Organization Technical Barriers to Trade (TBT) Committee.

2. Referenced Documents

2.1 ASTM Standards:³

[D1500 Test Method for ASTM Color of Petroleum Products \(ASTM Color Scale\)](#)

[D4175 Terminology Relating to Petroleum Products, Liquid Fuels, and Lubricants](#)

[E1 Specification for ASTM Liquid-in-Glass Thermometers](#)

3. Terminology

3.1 Definitions:

3.1.1 For definitions of terms used in this test method, refer to Terminology [D4175](#).

3.1.2 *aniline point, n*—the minimum equilibrium solution temperature for equal volumes of aniline and sample.

3.1.3 *mixed aniline point, n*—the minimum equilibrium solution temperature of a mixture of two volumes of aniline, one volume of sample, and one volume of *n*-heptane of specified purity.

4. Summary of Test Method

4.1 Specified volumes of aniline and sample, or aniline and sample plus *n*-heptane, are placed in a tube and mixed mechanically. The mixture is heated at a controlled rate until the two phases become miscible. The mixture is then cooled at a controlled rate and the temperature at which two phases separate is recorded as the aniline point or mixed aniline point.

5. Significance and Use

5.1 The aniline point (or mixed aniline point) is useful as an aid in the characterization of pure hydrocarbons and in the analysis of hydrocarbon mixtures. Aromatic hydrocarbons exhibit the lowest, and paraffins the highest values. Cycloparaffins and olefins exhibit values that lie between those for paraffins and aromatics. In homologous series the aniline points increase with increasing molecular weight. Although it occasionally is used in combination with other physical properties in correlative methods for hydrocarbon analysis, the aniline point is most often used to provide an estimate of the aromatic hydrocarbon content of mixtures.

6. Apparatus

6.1 For details of the aniline point apparatus required for each method see:

[Annex A1](#) for Test Method A

[Annex A2](#) for Test Method B

[Annex A3](#) for Test Method C

[Annex A4](#) for Test Method D

[Annex A5](#) for Test Method E

NOTE 1—Alternative apparatus may be used, such as the U-tube method for dark oils, provided it has been shown to give results of the same precision and accuracy as those described in the annexes.

6.2 *Heating and Cooling Bath*—A suitable air bath, a nonvolatile, transparent liquid bath, or an infrared lamp (250 W to 375 W), provided with means for controlling the rate of heating.

NOTE 2—Water should not be used as either a heating or cooling medium since aniline is hygroscopic and moist aniline will give erroneous test results. For example, the aniline point of the *n*-heptane reagent as measured with aniline containing 0.1 % by volume water is approximately 0.5 °C (0.9 °F) higher than that measured with dry aniline. If the aniline point is below the dew point of the atmosphere, pass a slow stream of dry inert gas into the aniline point tube to blanket the aniline-sample mixture.

³ For referenced ASTM standards, visit the ASTM website, www.astm.org, or contact ASTM Customer Service at service@astm.org. For *Annual Book of ASTM Standards* volume information, refer to the standard's Document Summary page on the ASTM website.

6.3 *Thermometers*, or other temperature sensing devices, such as thermocouples or platinum resistance thermometers that cover the temperamental range of interest and can provide equivalent or better accuracy and precision, may be used in place of the thermometers having the following ranges and conforming to the requirements of the designated ASTM or IP specification:

Range	ASTM (Specification E1)	IP
-38 °C to + 42 °C (-36.5 °F to + 107.5 °F)	33C, 33F	20C
25 °C to 105 °C (77 °F to 221 °F)	34C, 34F	21C
90 °C to 170 °C (194 °F to 338 °F)	35C, 35F	59C

6.4 *Pipets*, or equivalent volume dispensing devices, capable of delivering volumes with capacities of 10 mL ± 0.04 mL and 5 mL ± 0.02 mL, for use in the test.

6.5 *Balance*—A laboratory balance sensitive to 0.01 g, suitable for weighing the tube and sample when the sample cannot be pipetted conveniently.

6.6 *Safety Goggles*.

6.7 *Plastic Gloves*, impervious to aniline.

7. Reagents

7.1 *Aniline* (**Warning**—Aniline should not be pipetted directly by mouth because of its extreme toxicity. Aniline is also toxic by absorption through the skin even in *very small quantities*, and should be handled with great caution.) The aniline shall be sufficiently pure such that when tested with *n*-heptane according to Section 9, it shall give an aniline point of 69.3 °C ± 0.2 °C (156.7 °F ± 0.4 °F) as determined from the average of two independent tests having a difference of not more than 0.1 °C (0.2 °F). If the aniline point of heptane is higher than this specification, the aniline may be dried by distillation, where the first and last 10 % are discarded. If the aniline point is lower, water may be added until the aniline meets the specification.

NOTE 3—It is estimated that approximately 400 ppm to 1400 ppm of water in aniline is required to meet the heptane specification.

NOTE 4—As an alternative to distilling the aniline on the day of use, the aniline may be distilled as described in 7.1, collecting the distillate in ampoules, sealing the ampoules under vacuum or dry nitrogen, and storing in a cool dark place for future use. Alternatively, distillate may be stored under dry nitrogen in a glass bottle or in single use ampoules kept in a cool, dark place. In either case, rigid precaution must be taken to avoid contamination from atmospheric moisture (Note 2). It is believed that under these conditions the aniline will remain unchanged for a period exceeding 6 months.

7.2 *Calcium Sulfate*, anhydrous.

7.3 *n-Heptane*, spectroscopic or HPLC grade. (**Warning**—Flammable. Harmful if inhaled. Keep away from heat, sparks, and open flame. Keep container closed. Use with adequate ventilation. Avoid prolonged breathing of vapor or spray mist. Avoid prolonged or repeated skin contact.)

8. Sample

8.1 Dry the sample by shaking vigorously for 3 min to 5 min with about 10 % by volume of a suitable drying agent such as anhydrous calcium sulfate or anhydrous sodium sulfate. Reduce the viscosity of viscous samples by warming to a temperature below that which would cause the loss of light ends or the dehydration of the drying agent. Remove any suspended drying agent by use of a centrifuge or by filtration. Heat samples containing separated wax until they are homogeneous and keep heated during filtration or centrifugation to ensure against separation of wax. When suspended water is visibly present and the sample material is known to dissolve less than 0.03 % by mass of water, the use of a centrifuge for the removal of suspended water is an acceptable procedure.

9. Procedure for Aniline Point

9.1 The following methods, to be used as applicable, are covered as follows:

9.1.1 *Test Method A*, described in detail in [Annex A1](#), is applicable to clear samples or to samples not darker than No. 6.5 ASTM color, as determined by Test Method [D1500](#), having initial boiling points well above the expected aniline point.

9.1.2 *Test Method B*, described in detail in [Annex A2](#), is applicable to light-colored samples, moderately dark samples, and to very dark samples. It is suitable for samples that are too dark to be tested by Test Method A.

9.1.3 *Test Method C*, described in detail in [Annex A3](#), is applicable to clear samples or to samples not darker than No. 6.5 ASTM color, as determined by Test Method [D1500](#), having initial boiling points sufficiently low as to give incorrect aniline point readings by Test Method A, for example, aviation gasoline.

9.1.4 *Test Method D*, described in detail in [Annex A4](#), is applicable to the same type of sample as Test Method C. It is particularly useful when only limited quantities of sample are available.

9.1.5 *Test Method E* is applicable when using automatic apparatus in accordance with the instructions in [Annex A5](#).

10. Procedure for Mixed Aniline Point

10.1 This procedure is applicable to samples having aniline points below the temperature at which aniline crystallizes from the mixture. Deliver 10 mL of aniline (**Warning**—See [7.1](#)), 5 mL of sample, and 5 mL of *n*-heptane into a clean, dry apparatus. Determine the aniline point of the mixture by Test Method A or B as described in [Annex A1](#) or [Annex A2](#).

11. Report

11.1 If the range of three successive observations of the aniline point temperature is not greater than 0.1 °C (0.2 °F) for light-colored samples or 0.2 °C (0.4 °F) for dark samples, report the average temperature of these observations, corrected for thermometer calibration errors, to the nearest 0.05 °C (0.1 °F) as the aniline point.

11.2 If such a range is not obtained after five observations, repeat the test using fresh quantities of aniline and sample in a clean, dry apparatus, and if consecutive temperature observations show a progressive change, or if the range of observations is greater than the repeatability given in [12.1](#), report the test method as being inapplicable.

12. Precision and Bias

12.1 The precision of these test methods as obtained by statistical examination of interlaboratory test results is as follows:

12.1.1 *Repeatability*—The difference between successive test results (two average temperatures obtained in a series of observations as described in Section [11](#) obtained by the same operator with the same apparatus under constant operating conditions on identical test material, would in the long run, in the normal and correct operation of the test method, exceed the following values only in one case in twenty:

Aniline point of:		Repeatability
Clear, light-colored samples	0.16 °C	(0.3 °F)
Moderately dark to very dark samples	0.3 °C	(0.6 °F) ^A
Mixed aniline point of:		
Clear, light-colored samples	0.16 °C	(0.3 °F) ^A
Moderately dark to very dark samples	0.3 °C	(0.6 °F) ^A

^A Not determined from recent cooperative tests; however, the ratios with those given in the 1953 version are believed to apply.

12.1.2 *Reproducibility*—The difference between two single and independent results, obtained by different operators, working in different laboratories on identical test material, would in the long run, in the normal and correct operation of the test method, exceed the following values only in one case in twenty:

		Reproducibility
Aniline point of:		
Clear, light-colored samples	0.5 °C	(0.9 °F)
Moderately dark to very dark samples	1.0 °C ^A	(1.8 °F)
Mixed aniline point of:		
Clear, light-colored samples	0.7 °C	(1.3 °F) ^A
Moderately dark to very dark samples	1.0 °C	(1.8 °F) ^A

^A Not determined from recent cooperative tests; however, the ratios with those given in the 1953 version are believed to apply.

12.2 *Bias*—Since there is no accepted reference material suitable for determining the bias for the procedure in these test methods, bias has not been determined.

12.3 The precision of this test was not obtained in accordance with Committee D02 Research Report RR:D02-1007, “Manual on Determining Precision Data for ASTM Methods on Petroleum Products and Lubricants.”

13. Keywords

13.1 aniline point; aromatics; mixed aniline point

ANNEXES

(Mandatory Information)

A1. TEST METHOD A

A1.1 Apparatus

A1.1.1 The apparatus shown in Fig. A1.1 shall consist of the following:

A1.1.1.1 *Test Tube*, approximately 25 mm in diameter and 150 mm in length, made of heat-resistant glass.

A1.1.1.2 *Jacket*, approximately 37 mm to 42 mm in diameter and 175 mm in length, made of heat-resistant glass.

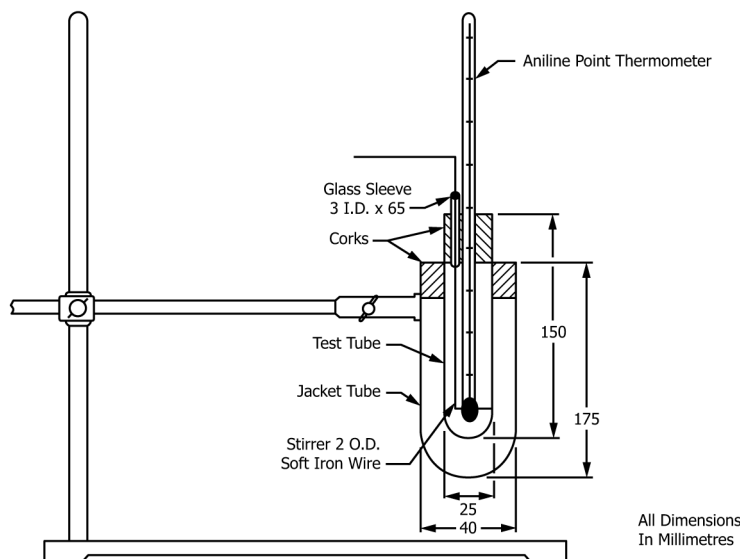

FIG. A1.1 Aniline Point Apparatus (Test Method A)

A1.1.1.3 *Stirrer*; manually operated, metal, approximately 2 mm in diameter (14 B&S gage) metal wire as shown in Fig. A1.1. A concentric ring shall be at the bottom, having a diameter of approximately 19 mm. The length of the stirrer to a right-angle bend shall be approximately 200 mm. The right-angle bend shall be approximately 55 mm long. A glass sleeve approximately 65 mm in length of 3 mm inside diameter shall be used as a guide for the stirrer. Any suitable mechanical device for operating the stirrer as specified is an approved alternative for the manual operation.

A1.2 Procedure

A1.2.1 Clean and dry the apparatus. Deliver 10 mL of aniline (**Warning**—See 7.1) and 10 mL of the dried sample (8.1) into the test tube fitted with stirrer and thermometer. If the material is too viscous for volumetric transfer, weigh to the nearest 0.01 g a quantity of the sample corresponding to 10 mL at room temperature. Center the thermometer in the test tube so that the immersion mark is at the liquid level, making sure that the thermometer bulb does not touch the side of the tube. Center the test tube in the jacket tube. Stir the mixture rapidly using a 50 mm (2 in.) stroke, avoiding the introduction of air bubbles.

A1.2.2 If the aniline-sample mixture is not miscible at room temperature, apply heat directly to the jacket tube so that the temperature rises at a rate of 1 °C to 3 °C (2 °F to 5 °F)/min by removing or reducing the heat source until complete miscibility is obtained. Continue stirring and allow the mixture to cool at a rate of 0.5 °C to 1.0 °C (1.0 °F to 1.8 °F)/min. Continue cooling to a temperature of 1 °C to 2 °C (2.0 °F to 3.5 °F) below the first appearance of turbidity, and record as the aniline point the temperature at which the mixture suddenly becomes cloudy throughout (Note A1.1). This temperature, and not the temperature of separation of small amounts of material, is the minimum equilibrium solution temperature.

NOTE A1.1—The true aniline point is characterized by a turbidity that is so cloudy as to obscure the thermometer bulb in reflected light.

A1.2.3 If the aniline-sample mixture is completely miscible at room temperature, substitute a non-aqueous cooling bath for the heating source, allow to cool at the rate specified in A1.2.2 and determine the aniline point as described.

<https://standards.iteh.ai/catalog/standards/sist/a89c3c1b-b0de-4e41-a9bd-66dbad0bb6c6/astm-d611-23>

A1.2.4 Repeat the observation of aniline point temperature by heating and cooling repeatedly until a report as directed in Section 11 can be made.

A2. TEST METHOD B

A2.1 Apparatus

A2.1.1 *Thin-Film Apparatus*, made of heat-resistant glass and stainless steel, conforming to the dimensions given in Fig. A2.1. A suggested assembly is shown in Fig. A2.2.

A2.2 Procedure

A2.2.1 Clean and dry the apparatus. Deliver 10 mL of aniline (**Warning**—See 7.1) and 10 mL of the dried sample (8.1) into the tube fitted with pump-stirrer and thermometer. If the material is too viscous for volumetric transfer, weigh to the nearest 0.01 g

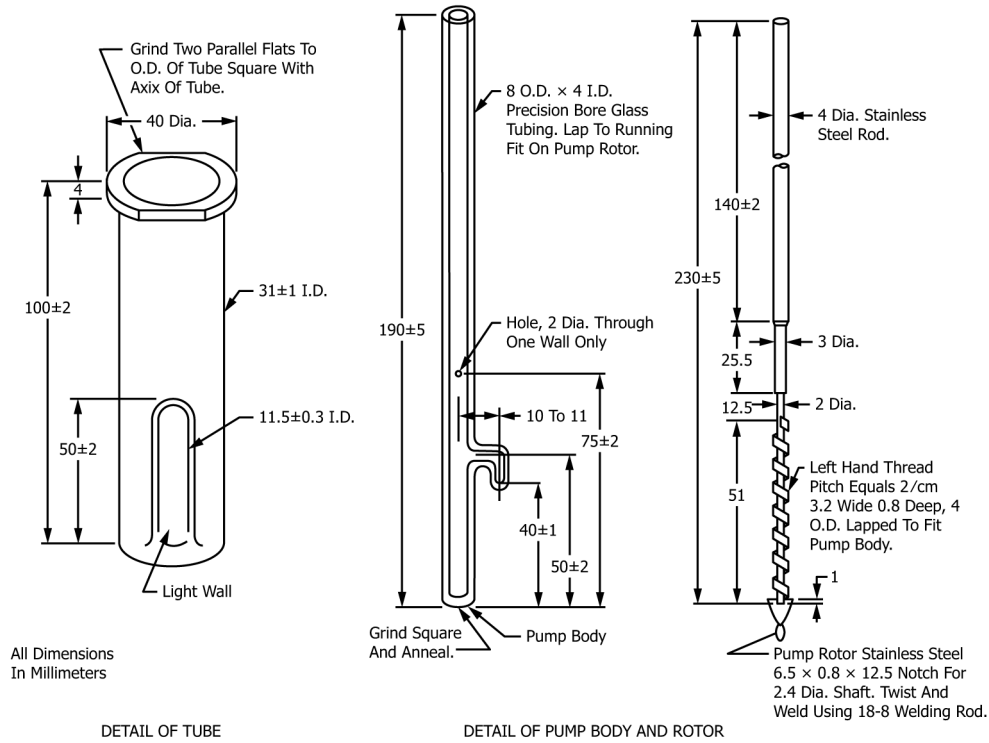

FIG. A2.1 Details of Aniline Point Thin-Film Apparatus (Test Method B)

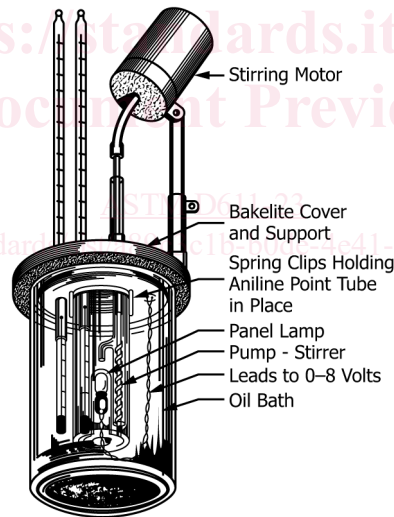

FIG. A2.2 Assembly of Thin-Film Apparatus (Test Method B)

a quantity of sample corresponding to 10 mL at room temperature. Place the thermometer in the tube so that the contraction chamber is below the liquid level and so that the mercury bulb does not touch the side of the tube. Assemble the apparatus as shown in Fig. A2.2.

A2.2.2 Adjust the speed of the pump to produce a continuous stream of the oil-aniline mixture in the form of a thin film flowing over the light well. With extremely dark oils, operate the pump slowly and lower it so that the delivery tube nearly touches the top of the light well, so as to obtain a continuous film thin enough to permit observation of the aniline point. Adjust the voltage on the lamp until just enough light is given for the filament to be visible through the film. Raise the temperature of the mixture at a rate of 1 °C to 2 °C (2.0 °F to 3.5 °F)/min until the aniline point has just been passed, as denoted by a definite, sudden brightening of the lamp filament, and by the disappearance of the more or less opalescent condition of the film (Note A2.1). Discontinue heating and adjust the lamp voltage so that the filament appears clear and distinct but not uncomfortably bright to the