



Designation: E2021 – 15 (Reapproved 2023)

Standard Test Method for Hot-Surface Ignition Temperature of Dust Layers¹

This standard is issued under the fixed designation E2021; the number immediately following the designation indicates the year of original adoption or, in the case of revision, the year of last revision. A number in parentheses indicates the year of last reapproval. A superscript epsilon (ϵ) indicates an editorial change since the last revision or reapproval.

1. Scope

1.1 This test method covers a laboratory procedure to determine the hot-surface ignition temperature of dust layers, that is, measuring the minimum temperature at which a dust layer will self-heat. The test consists of a dust layer heated on a hot plate.^{2,3}

1.2 Data obtained from this test method provide a relative measure of the hot-surface ignition temperature of a dust layer.

1.3 This test method should be used to measure and describe the properties of materials in response to heat and flame under controlled laboratory conditions and should not be used to describe or appraise the fire hazard or fire hazard risk of materials, products, or assemblies under actual fire conditions. However, results of this test method may be used as elements of a fire risk assessment that takes into account all of the factors that are pertinent to an assessment of the fire hazard risk of a particular end use product.

1.4 The values stated in SI units are to be regarded as standard. No other units of measurement are included in this standard.

1.5 *This standard does not purport to address all of the safety concerns, if any, associated with its use. It is the responsibility of the user of this standard to establish appropriate safety, health, and environmental practices and determine the applicability of regulatory limitations prior to use.* Specific precautionary statements are given in Section 8.

1.6 *This international standard was developed in accordance with internationally recognized principles on standardization established in the Decision on Principles for the Development of International Standards, Guides and Recommendations issued by the World Trade Organization Technical Barriers to Trade (TBT) Committee.*

¹ This test method is under the jurisdiction of ASTM Committee E27 on Hazard Potential of Chemicals and is the direct responsibility of Subcommittee E27.04 on the Flammability and Ignitability of Chemicals.

Current edition approved May 1, 2023. Published May 2023. Originally approved in 1999. Last previous edition approved in 2015 as E2021 – 15. DOI: 10.1520/E2021-15R23

² This test method is based on recommendations of the National Materials Advisory Board of the National Academy of Sciences (1).³

³ The boldface numbers in parentheses refer to the list of references at the end of this standard.

2. Referenced Documents

2.1 ASTM Standards:⁴

E771 Test Method for Spontaneous Heating Tendency of Materials (Withdrawn 2001)⁵

E1445 Terminology Relating to Hazard Potential of Chemicals

E1491 Test Method for Minimum Autoignition Temperature of Dust Clouds

2.2 IEC Standard:⁶

IEC 1241-2-1 Electrical Apparatus for Use in the Presence of Combustible Dust; Part 2: Test Methods—Section 1: Methods for Determining the Minimum Ignition Temperatures of Dusts, Method A

3. Terminology

3.1 *Definitions*—For definitions of other terms used in this standard, see Terminology E1445.

3.2 Definitions of Terms Specific to This Standard:

3.2.1 *hot-surface ignition temperature of a dust layer, n*—lowest set temperature of the hot plate that causes ignition of the dust layer.

3.2.2 *ignition of a dust layer, n*—initiation of self-heating or combustion in a material under test.

3.2.3 *ignition time, n*—time between the start of heating and the point at which the maximum temperature or flaming combustion is reached.

3.2.4 *temperature rise, ΔT , n*—the difference between T_{max} and the initial set temperature of the hot plate.

3.2.5 T_{max} , *n*—maximum temperature measured during test.

4. Summary of Test Method

4.1 The test material is placed within a metal ring on top of a hot plate, that is at a preset constant temperature.

⁴ For referenced ASTM standards, visit the ASTM website, www.astm.org, or contact ASTM Customer Service at service@astm.org. For *Annual Book of ASTM Standards* volume information, refer to the standard's Document Summary page on the ASTM website.

⁵ The last approved version of this historical standard is referenced on www.astm.org.

⁶ Available from American National Standards Institute (ANSI), 25 W. 43rd St., 4th Floor, New York, NY 10036, <http://www.ansi.org>.

4.2 The sample temperature is monitored to determine temperature rise due to oxidative reactions or decomposition reactions, or both.

4.3 Ignition is considered to have taken place when either of the following occurs:

4.3.1 Temperature in the dust layer at position of thermocouple rises at least 50 °C above the hot plate temperature, or

4.3.2 Visible evidence of combustion is apparent, such as red glow or flame.

4.4 Hot plate surface temperature is varied from test to test, as necessary, until the hot-surface ignition temperature is determined.

5. Significance and Use

5.1 This test method is applicable to dusts and powders, and provides a procedure for performing laboratory tests to evaluate hot-surface ignition temperatures of dust layers.

5.2 The test data can be of value in determining safe operating conditions in industrial plants, mines, manufacturing processes, and locations of material usage and storage.

5.3 Due to variation of ignition temperature with layer thickness, the test data at one thickness may not be applicable to all industrial situations (see Appendix X1). Tests at various layer thicknesses may provide a means for extrapolation to thicker layers, as listed in the following for pulverized Pittsburgh bituminous coal dust (2). Mathematical modeling of layer ignition at various layer thicknesses is described in Ref. (3).

Layer Thickness, mm	Hot-Surface Ignition Temperature, °C
6.4	300
9.4	260
12.7	240
25.4	210

5.4 This hot plate test method allows for loss of heat from the top surface of the dust layer, and therefore generally gives a higher ignition temperature for a material than Test Method E771, which is a more adiabatic system.

5.5 This test method for dust layers generally will give a lower ignition temperature than Test Method E1491, which is for dust clouds. The layer ignition temperature is determined while monitoring for periods of minutes to hours, while the dust cloud is only exposed to the furnace for a period of seconds.

NOTE 1—Much of the literature data for layer ignition is actually from a basket in a heated furnace (4), known as the modified Godbert-Greenwald furnace test. Other data are from nonstandardized hot plates (5-9).

5.6 Additional information on the significance and use of this test method may be found in Ref. (10).

6. Limitations and Interferences

6.1 This test method should not be used with materials having explosive or highly reactive properties.

6.2 If the metal (for example, aluminum) plate or ring reacts with the test material, choose another type of metal that does not react.

7. Apparatus

7.1 The complete apparatus, shown in Fig. 1, consists of a circular metal (for example, aluminum) plate centrally positioned on top of a hot plate. The dust layer is confined within a metal ring on top of the metal plate. An example of an apparatus that has been found suitable is given in Appendix X2.

7.1.1 *Heated Surface*, consisting of a metal plate of approximately 200 mm diameter and at least 20 mm thick. This plate is centrally placed on top of a commercial hotplate. A thermocouple is mounted radially in the metal plate, with its junction in contact with the plate within 1.0 mm ± 0.5 mm of the upper surface. This thermocouple is connected to a temperature controller. The plate and its thermocouple-controller assembly, in conjunction with the commercial hotplate, should satisfy the following requirements:

7.1.1.1 The plate should be capable of attaining a maximum temperature of 450 °C without a dust layer in position,

7.1.1.2 The temperature controller must be capable of maintaining the temperature of the plate constant to within ±5 °C throughout the time period of the test,

7.1.1.3 When the temperature of the plate has reached a constant value, the temperature across the plate should be uniform to within ±5 °C, as shown in Fig. 2,

7.1.1.4 The temperature control should be such that the recorded plate temperature will not change by more than ±5 °C during the placing of the dust layer and will be restored to within 2 °C of the previous value within 5 min of placing the dust layer, and

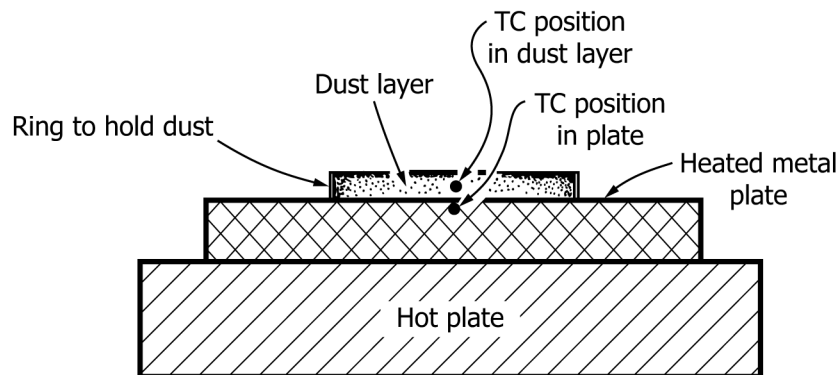

FIG. 1 Schematic of Hotplate Layer Ignition Apparatus

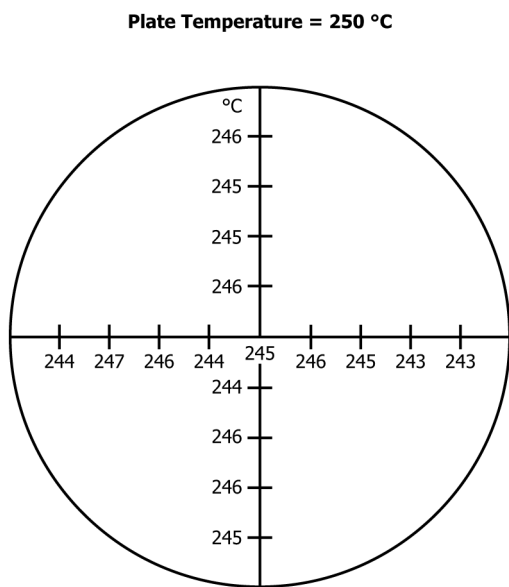

FIG. 2 Uniformity of Aluminum Plate Temperature at Set Temperature of 250 °C

7.1.1.5 The thermocouple in the plate and its readout device should be calibrated and should be accurate to within ± 3 °C.

7.1.2 *Metal Ring*, to be placed on the heated metal plate, for containing the dust layer. Stainless steel is suitable for most dusts. The standard ring is 12.7 mm ($\frac{1}{2}$ in.) in depth and approximately 100 mm (4 in.) in diameter. Rings may be of other depths.

7.1.3 *Dust Layer Thermocouple*—Slots on opposite sides of the perimeter of the ring accommodate the positioning of a type K bare thermocouple (0.20 mm to 0.25 mm or 10 mil in diameter) through the dust sample. This bare thermocouple is positioned parallel to the surface of the metal plate with its junction at the geometric center of the dust layer. This thermocouple should be connected to a digital thermometer for observing the temperature of a dust layer during a test. Temperature measurements with the thermocouple should be made either relative to a fixed reference junction temperature or with automatic cold junction compensation. Most digital thermometers have built-in compensation. The thermocouple in the dust layer and its readout device should be calibrated and should be accurate to within ± 3 °C.

7.2 *Ambient Temperature Thermometer*, placed in a convenient position within 1 m of the hot plate but shielded from heat convection and radiation from the hot plate. The ambient temperature should be within the range of 15 °C to 30 °C.

8. Hazards

8.1 The user should consider the toxicity of the sample dust and possible combustion products.

8.2 This test method should not be used with materials having explosive or highly reactive properties.

8.3 Metal dusts can ignite and burn with high temperatures. If a flame is observed, the dust layer should be covered with a flat metal sheet to exclude the air and extinguish the flame.

8.4 The user should use due caution around the hot surfaces present on the test apparatus.

8.5 Tests should be conducted in a ventilated hood or other area having adequate ventilation to remove any smoke or fumes.

9. Sampling and Test Specimens

9.1 It is not practical to specify a single method of sampling dust for test purposes because the character of the material and its available form affect selection of the sampling procedure. Generally accepted sampling procedures should be used. See MNL 32 Manual on Test Sieving Methods.

9.2 Tests may be run on an as-received sample. However, since finer dusts have lower hot-surface ignition temperatures (2) and due to the possible accumulation of fines at some locations in a processing system, it is recommended that the test sample be at least 95 % minus 200 mesh (75 μ m). To achieve this particle fineness, grind, pulverize, or sieve the sample.

NOTE 2—The operator should consider the thermal stability and the friction and impact sensitivity of the dust during any grinding or pulverizing. In sieving the material, the operator must verify that there is no selective separation of components in a dust that is not a pure substance.

NOTE 3—It may be desirable in some cases to conduct dust layer ignition tests on a material as sampled from a process because (a) dust streams may contain a wide range of particle sizes or have a well-defined specific moisture content, (b) materials consisting of a mixture of chemicals may be selectively separated on sieves, and (c) certain fibrous materials may not pass through a relatively coarse screen. When a material is tested in the as-received state, it should be recognized that the test results may not represent the lowest dust layer ignition temperature possible. Any process change resulting in a higher fraction of fines than normal or drier product than normal may decrease the ignition temperature.

10. Calibration and Standardization

10.1 The calibration of the dust sample thermocouple and the thermocouple embedded in the circular metal plate must be checked using appropriate standards.

10.2 The temperature across the metal plate should be uniform to within ± 5 °C when measured across two diameters at right angles, as shown in Fig. 2. This requirement must be satisfied at two plate temperatures, one in the range of between 200 °C and 250 °C and the second in the range of between 300 °C and 350 °C, measured at the center of the plate.

10.3 Verify the performance of the apparatus using at least two dust layers having different hot-surface ignition temperatures. Representative data including both published and unpublished values (2)⁷ for 12.7 mm thick layers of three dusts are:

Brass	155 °C to 160 °C
Pittsburgh coal dust	230 °C to 240 °C
Lycopodium spores	240 °C to 250 °C

The brass was a very fine flake (100 % minus 325 mesh) with a small amount (<1.7 %) of stearic acid coating. The lycopodium is a natural plant spore having a narrow size

⁷ Some data are from unpublished work of the Fenwal (Marlborough, MA) and Fike (Blue Springs, MO) companies.

distribution with 100 % minus 200 mesh and mass median diameter of $\sim 28 \mu\text{m}$. This is the reticulate form *Lycopodium clavatum*. The Pittsburgh seam bituminous coal has $\sim 80 \%$ minus 200 mesh, a mass median diameter of $\sim 45 \mu\text{m}$, and 36 % volatility. Additional data that can be used for calibration are those listed in 5.3 for different layer thicknesses of this coal dust.

11. Procedure

11.1 *General Set-Up*—Set up the apparatus in a position free from drafts while exhausting smoke and fumes. Ensure that the air flow in the hood is sufficient for removing smoke and fumes, but low enough so as not to disturb the layer or affect the test results. This can be achieved by adjusting the baffles in the back of the hood. If desired, an angled mirror can be provided above the test sample for visual observation.

11.2 Procedure for Individual Test:

11.2.1 Centrally place a ring of the required height on the clean surface of the heated metal plate. Make adjustments to the thermocouple position. Set the desired test temperature on the temperature controller and heat the hot plate.

11.2.2 When hot plate temperature is steady within the required limit, fill the ring with the test dust, and level the surface of the layer within a period of 2 min. Do not compress the dust layer. Put the dust into the ring with a spatula and distribute with mainly sideways movements of the spatula until the ring is slightly over-filled; then, level the layer by drawing a straight edge across the top of the ring. Remove the excess dust that spills on the metal plate. The amount of dust that will just fill the ring can be predetermined so as to minimize spillage. Also to minimize spillage, it is convenient to use a scoop with a concave edge, as shown in Fig. 3, and to draw the straight edge towards the scoop.

NOTE 4—The bulk density of each dust should be determined to provide a reference should data on a similar material yield significantly different results in later tests. To determine the bulk density, a layer of dust is formed in the above manner on a tared sheet of paper and weighed. The bulk density should be measured two or three times and the average value should be reported. The bulk or apparent density is calculated from the weight of the dust and the filled volume of the ring.

11.2.3 Continuously monitor the temperatures of the hot plate and of the dust layer as a function of time to the end of the test. A typical test period is two hours. Continue the test if any self-heating is evident. Self-heating may be indicated by localized heavy smoke, or increasing temperature. Terminate the test if the layer has completely melted, ignited, or reached a maximum temperature without igniting and is cooling down.

NOTE 5—Ignition in particulate or fine dusts exposed to elevated temperatures generally is preceded by a more or less protracted period of self-heating, usually due to atmospheric oxidation. Depending on the temperature of exposure, self-heating may result in no more than a transient, although sometimes substantial, rise in temperature within the material that does not lead to the propagation of combustion. It is necessary to be certain that failure to ignite at a given temperature is not merely a result of premature termination of a test. Thus, the temperatures at which ignition fails to occur must be confirmed by continuing a test long enough to establish that any such transient self-heating is definitely decreasing in rate, and the temperature inside the layer is decreasing to a steady value comparable to or lower than the temperature of the hot plate. This behavior may often be accompanied by a discoloration of the dust but not by active and visible combustion of the layer. Discoloration shall not be considered to be an ignition.

11.2.4 Take the reported test temperature from the initial set temperature of the metal plate, not from the thermocouple in the dust layer.

11.3 Test Series Procedures:

11.3.1 Repeat at different temperatures with fresh layers of dust until a hot-surface ignition temperature is determined. Initially, the set temperature may be varied in $\sim 50 \text{ }^\circ\text{C}$ steps from run to run to get an approximate ignition temperature. However, for the final determination of ignition temperature, vary the set temperature in $10 \text{ }^\circ\text{C}$ increments. The ignition temperature must be high enough to cause ignition in the layer, but no more than $10 \text{ }^\circ\text{C}$ higher than a temperature that fails to cause ignition or self-heating. An example of test data at two temperatures is shown in Fig. 4. In this example, the hot-surface ignition temperature is $290 \text{ }^\circ\text{C}$, since the dust layer ignited at $290 \text{ }^\circ\text{C}$ but did not ignite at $280 \text{ }^\circ\text{C}$.

11.3.2 Confirm the ignition temperature by a duplicate test at the same temperature.

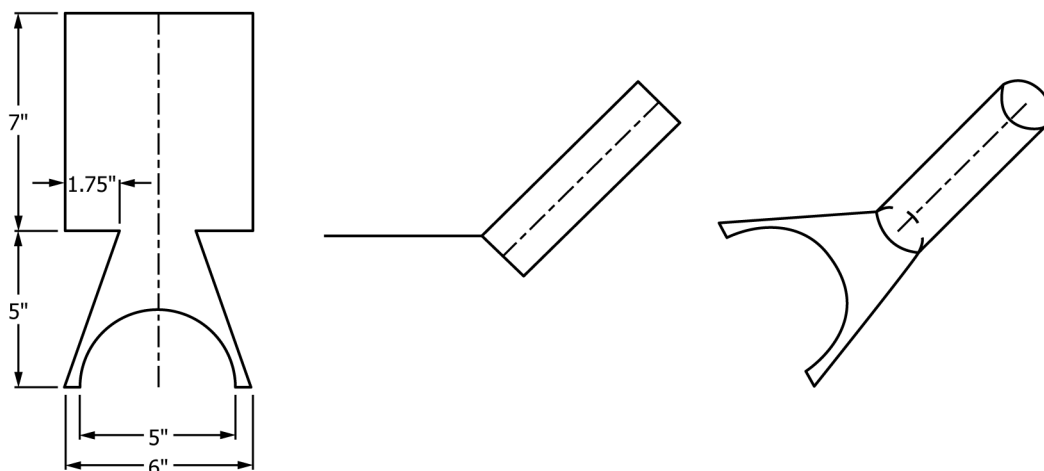

FIG. 3 Scoop Used to Remove Spillage

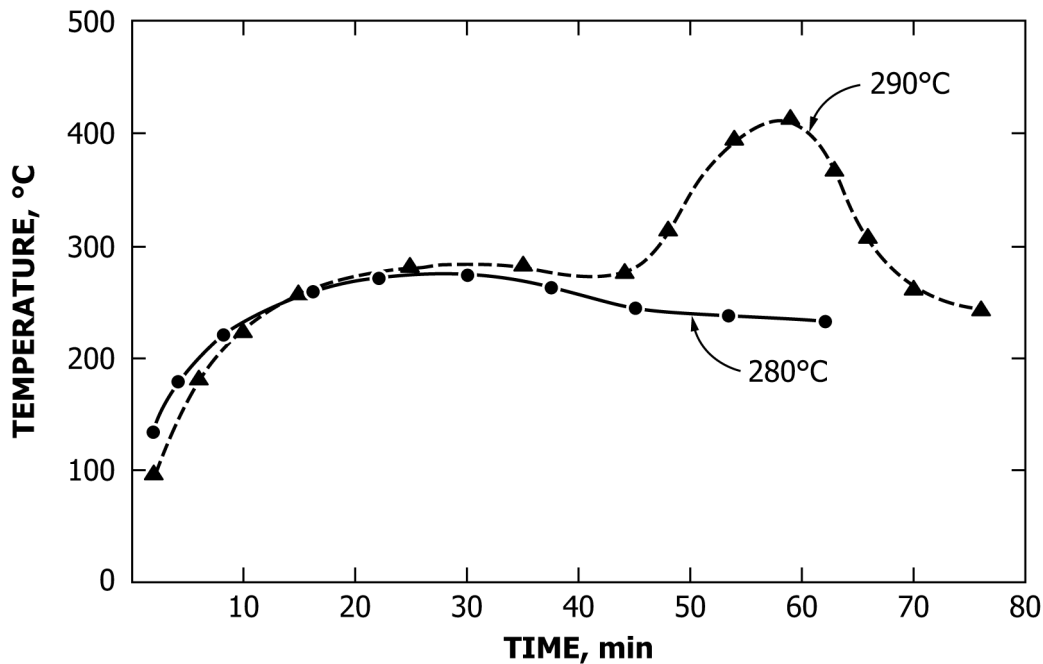

FIG. 4 Test Data Showing Nonignition at Set Temperature of 280 °C and Ignition at Set Temperature of 290 °C

11.3.3 Confirm the temperature at which ignition does not occur (10 °C lower than ignition temperature) by at least one duplicate test. Record this temperature.

11.3.4 Discontinue the test series if ignition of a dust layer does not occur at a set temperature of 450 °C. Report this fact and the maximum duration of the test.

11.3.5 If melting occurs, report this fact and the melting temperature, and discontinue the test series.⁸

11.3.6 If flames appear above the surface of the dust but the dust itself does not ignite, consider the temperature at which the flames appear to be the ignition temperature.⁹

11.3.7 If foaming¹⁰ of the dust layer occurs, record this fact and continue the testing until ignition, flaming, or melting is observed, or until the sample cools.

NOTE 6—With organic dusts, combustion usually takes the form of charring followed by smoldering and glowing that will progress through the layer and leave a residue of ash. Sugars, starches, and some other dusts turn dark, melt, expand, foam, and sometimes char with or without ignition. With dust layers composed of certain fine size metal powders, ignition may be characterized by the relatively sudden appearance of highly incandescent smoldering combustion progressing rapidly through the layer. Other fine metal powders may burn at a high temperature.

12. Report

12.1 Report the following information:

12.1.1 Complete identification of the sample including name, source, and description (if not implicit in the name) of the material tested,

12.1.2 The volatility, initial moisture, bulk density, and so forth, of the material, if known,

12.1.3 Hot surface ignition temperature of the dust layer, rounded to the nearest integral multiple of 10 °C,

12.1.4 Any observations of flame, smoke, etc.,

12.1.5 The highest temperature at which the dust layer did not ignite,

NOTE 7—Repeatability and reproducibility sometimes may be very poor for reasons associated with the physical nature of the dusts and the behavior of the dust layers during the test. When this occurs, it should be reported and all results should be accepted as equally valid. The test report should include a brief description of the nature of the combustion following ignition, especially noting behavior such as unusually rapid combustion or violent decomposition. Factors likely to affect the significance of the results also should be reported; these include difficulties in the preparation of layers, distortion of layers during heating, decrepitation, and melting.

12.1.6 Ignition time,

12.1.7 Depth of dust layer,

12.1.8 If the material does not ignite, report this fact and list the highest test temperature,

12.1.9 If the material melts before it ignites, report that melting occurred above the highest hot plate temperature at which no ignition was observed,

12.1.10 A complete table of test data should be included, an example of which is shown in Appendix X3, listing results in descending order of temperature rather than in the order in which the tests were performed,

12.1.11 Temperature-time curves for the tests may illustrate the results, and illuminate specific types of behavior, as shown in Fig. 4, and

12.1.12 Any changes from the standard test procedures.

⁸ Some materials, such as sulfur, melt prior to ignition.

⁹ This phenomenon may occur with some hydrides, for example.

¹⁰ Some dusts, such as starch, may foam when heated.

13. Precision and Bias

13.1 *Precision:*

13.1.1 *Repeatability*—Duplicate results for the same dust obtained by the same operator with the same apparatus should agree to within 10 °C.

13.1.2 *Reproducibility*—Results obtained for the same dust in different laboratories should agree to within 20 °C.

13.2 *Bias*—Because the values obtained are relative measures of ignition temperature, no statement on bias can be made.

14. Keywords

14.1 dust layer ignition; hot surface ignition; ignition temperature

APPENDIXES

(Nonmandatory Information)

X1. APPLICATION OF RESULTS

X1.1 The occurrence of ignition in a layer of dust on a surface at a given temperature depends critically on the balance between the rate of heat generation (self-heating) in the layer and the rate of heat loss to the surroundings. The temperature at which ignition of a given material occurs therefore depends on the thickness of the layer. It is beneficial to conduct tests at two or more layer thicknesses, especially at greater thicknesses, and to determine the hot-surface ignition temperatures for these thicker layers (2, 6). It is then possible to estimate hot-surface ignition temperatures for other layer thicknesses by interpolation or extrapolation of the experimental results, when plotted as the logarithm of the thickness versus the reciprocal of the ignition temperature in K. This is the simplest predictive procedure that has some theoretical

justification. More elaborate treatment based on thermal ignition theory (3) will permit estimates of the ignition temperatures of layers in other configurations (for example, layers on curved surfaces). However, if accurate predictions of ignition temperature under widely different conditions of exposure (in particular, exposure to a symmetrical high-temperature environment rather than to an unsymmetrical environment like that on a hot plate) are desired, it is preferable to use results obtained for an experimental procedure matching the different environment more closely (for example, ignition in an oven, as in Test Method E771). When extensive prediction is intended, it is recommended that ignition temperatures be determined for at least three layer thicknesses and that thicker layers be emphasized.

X2. HOT-SURFACE LAYER IGNITION TEMPERATURE APPARATUS

X2.1 *Construction of Heater Surface*—Provided the requirements presented in 7.1 describing the heated surface (metal plate) are satisfied, the detailed construction of the heated surface is not critical. An example is shown in Figs. X2.1 and X2.2. The heated surface consists of a circular metal plate (aluminum or stainless steel) of approximately 200 mm diameter, at least 20 mm thick, and with a smooth surface. It should be provided with an insulating skirt or cover (G in Fig. X2.1). The metal plate may be mounted on any suitable electrically heated hot plate, as is commercially available. Ordinary steel is not recommended for the heated surface because of the potential for corrosion problems.

X2.1.1 There are two ways of achieving a sufficiently uniform temperature distribution across the heated plate, the

choice of which depends primarily on the heating device available. If the hot plate heater consists, for example, of exposed coiled filaments intended to run at red heat, there should be an air gap of about 10 mm between the heater and the plate so that heat transfer occurs by radiation and convection. If, however, the heater is designed for direct contact and heat transfer occurs mainly by conduction, the plate needs to be thicker so that hot spots are avoided. A thickness of not less than 20 mm is recommended.

X2.1.2 The general arrangement is shown in Figs. X2.1-X2.3. It is preferable to insert indicating and controlling thermocouples in holes drilled radially from the edge of the plate and parallel to the surface at a depth of 1 mm from the surface.

X2.2 *Measurement of Temperature Distribution on Heated Metal Surface*—Apparatus suitable for measuring the temperature distribution across the hot plate is illustrated in Fig. X2.3. The measuring element should consist of a fine thermocouple with the junction flattened and brazed to a disc of copper or brass foil 5 mm in diameter. This should be placed at a measuring point and covered with a piece of insulating material 5 mm in thickness and 10 mm to 15 mm in diameter, held by a vertical glass rod that moves freely in a tubular guide and to which a fixed load is applied (see Fig. X2.3).

X2.2.1 Temperature measurements should be made along two diameters at right angles and at points 20 mm apart and recorded as in Fig. 2. The thermocouple must be allowed to reach a steady temperature at each point.

X2.2.2 The measured surface temperature usually will be lower than the set point temperature of the plate depending on the detailed construction of the thermocouple. This is immaterial and can be ignored. The essential requirement is an accurate measurement of temperature differences rather than of absolute values.

X2.2.3 An alternate approach uses a handheld surface thermocouple probe fitted with insulation.

X2.3 *Measuring Thermocouple*—The measuring thermocouple in the center of the dust layer is held in place by two threaded metal rods, each supplied with a spring coil and a wingnut as shown in Fig. X2.3. This thermocouple can be lowered or raised, depending on layer thickness, using the wingnuts.

KEY

- | | | | |
|---|---------------------------------------|---|----------------------------------|
| A | Heated plate, 20-cm diam | E | Plate thermocouple to controller |
| B | Heating element | F | Dust layer thermocouple |
| C | Connection to controller-power supply | G | Insulating cover |
| D | Ring for dust layer, 10-cm diam | | |

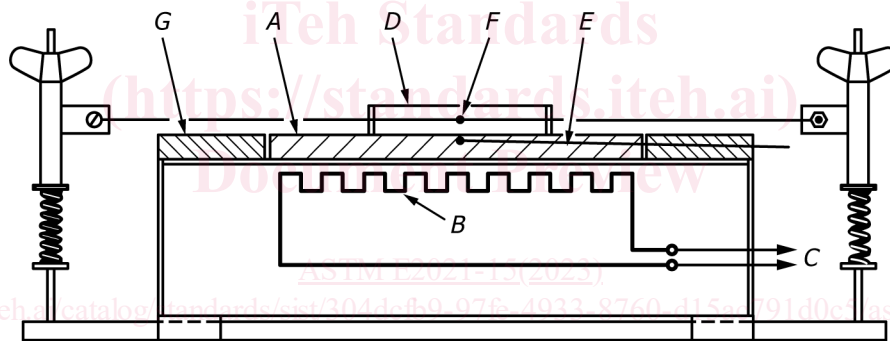

FIG. X2.1 Hot-Surface Layer Ignition Apparatus