



# Standard Specification for Gong, Sound Signaling<sup>1</sup>

This standard is issued under the fixed designation F957; the number immediately following the designation indicates the year of original adoption or, in the case of revision, the year of last revision. A number in parentheses indicates the year of last reapproval. A superscript epsilon ( $\epsilon$ ) indicates an editorial change since the last revision or reapproval.

*This standard has been approved for use by agencies of the U.S. Department of Defense.*

## 1. Scope

1.1 This specification covers gongs for use on ships 100 m or more in length, as required by International Regulations (see [Appendix X1](#)).

1.2 For consistency with International Regulations, all measurements are in SI units.

1.3 The values stated in SI units are to be regarded as standard. No other units of measurement are included in this standard.

1.4 *This international standard was developed in accordance with internationally recognized principles on standardization established in the Decision on Principles for the Development of International Standards, Guides and Recommendations issued by the World Trade Organization Technical Barriers to Trade (TBT) Committee.*

## 2. Referenced Documents

2.1 *ASTM Standards:*<sup>2</sup>

[A167 Specification for Stainless and Heat-Resisting Chromium-Nickel Steel Plate, Sheet, and Strip \(Withdrawn 2014\)](#)<sup>3</sup>

[A276 Specification for Stainless Steel Bars and Shapes](#)

[D3951 Practice for Commercial Packaging](#)

2.2 *American Welding Society Standard:*<sup>4</sup>

[AWS D1.1 Structural Welding Code](#)

2.3 *Federal Specifications:*<sup>5</sup>

[PPP-B-576 Box, Wood, Cleated, Veneer, Paper Overlaid](#)

[PPP-B-585 Boxes, Wood, Wirebound](#)

<sup>1</sup> This specification is under the jurisdiction of ASTM Committee F25 on Ships and Marine Technology and is the direct responsibility of Subcommittee F25.07 on General Requirements.

Current edition approved May 1, 2023. Published June 2023. Originally approved in 1985. Last previous edition approved in 2018 as F957 – 91 (2018). DOI: 10.1520/F0957-23.

<sup>2</sup> For referenced ASTM standards, visit the ASTM website, [www.astm.org](http://www.astm.org), or contact ASTM Customer Service at [service@astm.org](mailto:service@astm.org). For *Annual Book of ASTM Standards* volume information, refer to the standard's Document Summary page on the ASTM website.

<sup>3</sup> The last approved version of this historical standard is referenced on [www.astm.org](http://www.astm.org).

<sup>4</sup> Available from American Welding Society (AWS), 8669 NW 36 St., #130, Miami, FL 33166-6672, <http://www.aws.org>.

<sup>5</sup> Available from DLA Document Services, Building 4/D, 700 Robbins Ave., Philadelphia, PA 19111-5094, <http://quicksearch.dla.mil>.

[PPP-B-591 Boxes, Fiberboard, Wood-cleated](#)

[PPP-B-601 Boxes, Wood, Cleated Plywood](#)

[PPP-B-621 Boxes, Wood, Nailed and Lock Corner](#)

2.4 *Military Standard:*<sup>5</sup>

[MIL-STD-129 Marking for Shipment and Storage](#)

## 3. Ordering Information

3.1 Orders for gongs under this specification shall include the following information:

3.1.1 ASTM designation and year of issue.

3.1.2 Number of gongs.

3.1.3 Packaging and marking, if other than commercial.

## 4. Materials and Manufacture

4.1 *Materials:*

4.1.1 The gong cylinder, brackets, clapper rod, "U" bracket, washers, and clapper support pin shall be of stainless steel, in accordance with Specification [A167](#), UNS number S31600.

4.1.2 The clapper mass shall be of cast alloy steel in accordance with Specification [A276](#), UNS S31600.

4.1.3 The support bolt, nut, flat washer, and cotter pins shall be of stainless steel compatible with the other materials.

4.2 *Welding:*

4.2.1 Welding shall be of the type and sizes shown in [Fig. 1](#) and [Fig. 2](#), and in accordance with Standard AWS D1.1.

4.3 *Manufacture:*

4.3.1 [Fig. 1](#) shows the general arrangement of the assembled gong, as well as details of the gong cylinder. [Fig. 2](#) shows details of the brackets, clapper, and miscellaneous fittings.

4.3.2 The gong cylinder may be made from two pieces welded together, instead of one piece. Two piece construction shall be annealed to remove residual stresses.

4.3.3 Sharp corners and edges of the cylinder shall be broken.

4.3.4 The two brackets shall be welded together before being welded to the cylinder. The flanged ends of the brackets may be left straight and not shaped to the cylinder.

4.3.5 The clapper mass shall be welded to the clapper rod before forming the second eye.

4.4 *Extra Parts:*

4.4.1 Two extra supporting nuts and flat washers shall be furnished with each gong.

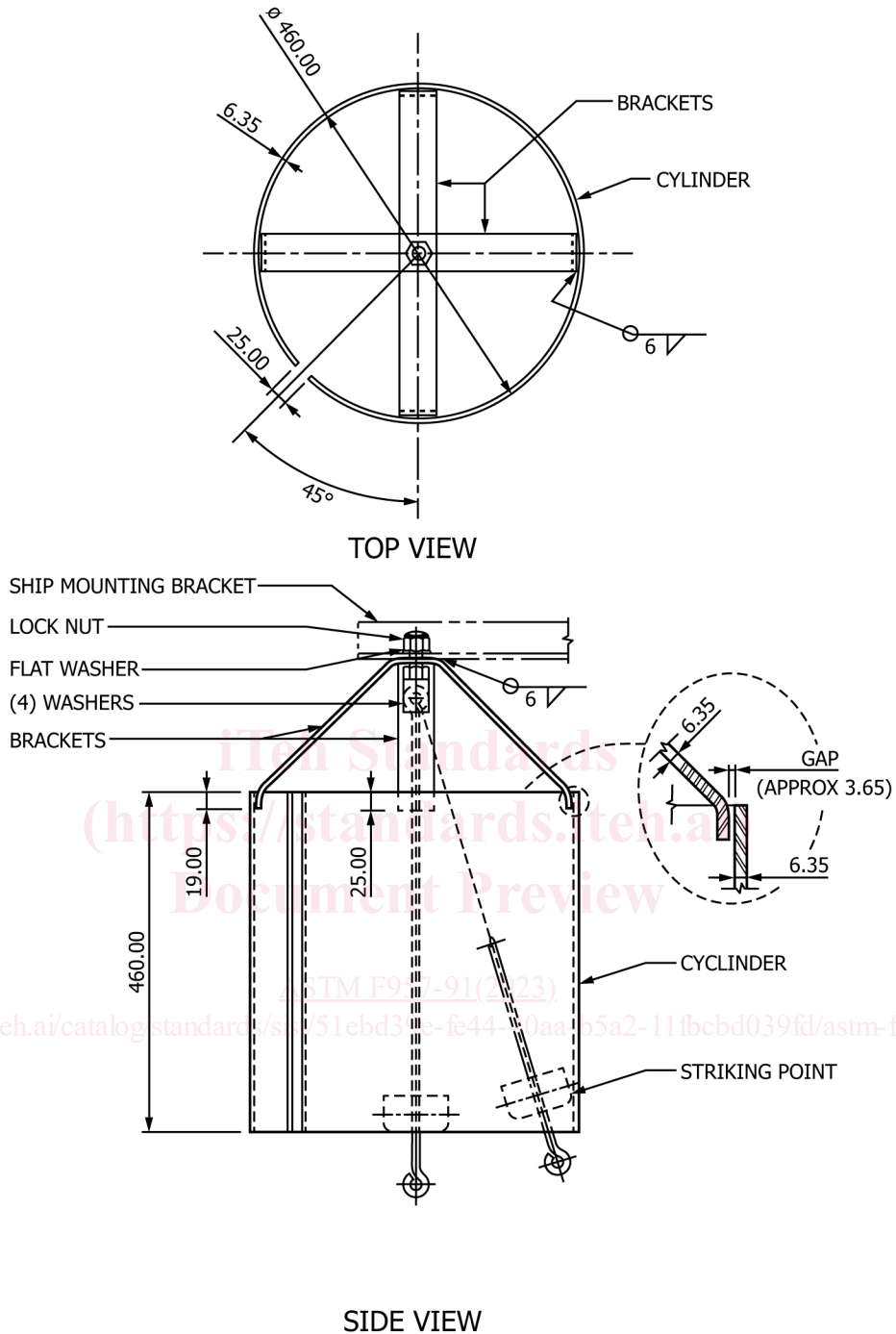

NOTE 1—All dimensions in millimetres.

FIG. 1 Assembly of Gong

## 5. Acoustic Requirements

5.1 The sound characteristics shall produce a sound pressure level of not less than 110 dB at a distance of 1 m.

## 6. Dimensions and Tolerances

6.1 Dimensions shall conform to Fig. 1 and Fig. 2.

6.2 Tolerances shall be as follows:

6.2.1 Up to 10 mm:  $\pm 1$  mm.

6.2.2 10 mm to 50 mm:  $\pm 2$  mm.

6.2.3 Over 50 mm:  $\pm 3$  mm.

## 7. Workmanship, Finish, and Appearance

7.1 Gongs shall be free from cracks, burrs, sharp cutting edges, and other defects affecting their life, appearance, and serviceability.

## 8. Sampling

8.1 For orders of 1 or 2 gongs, each gong shall be inspected and tested.

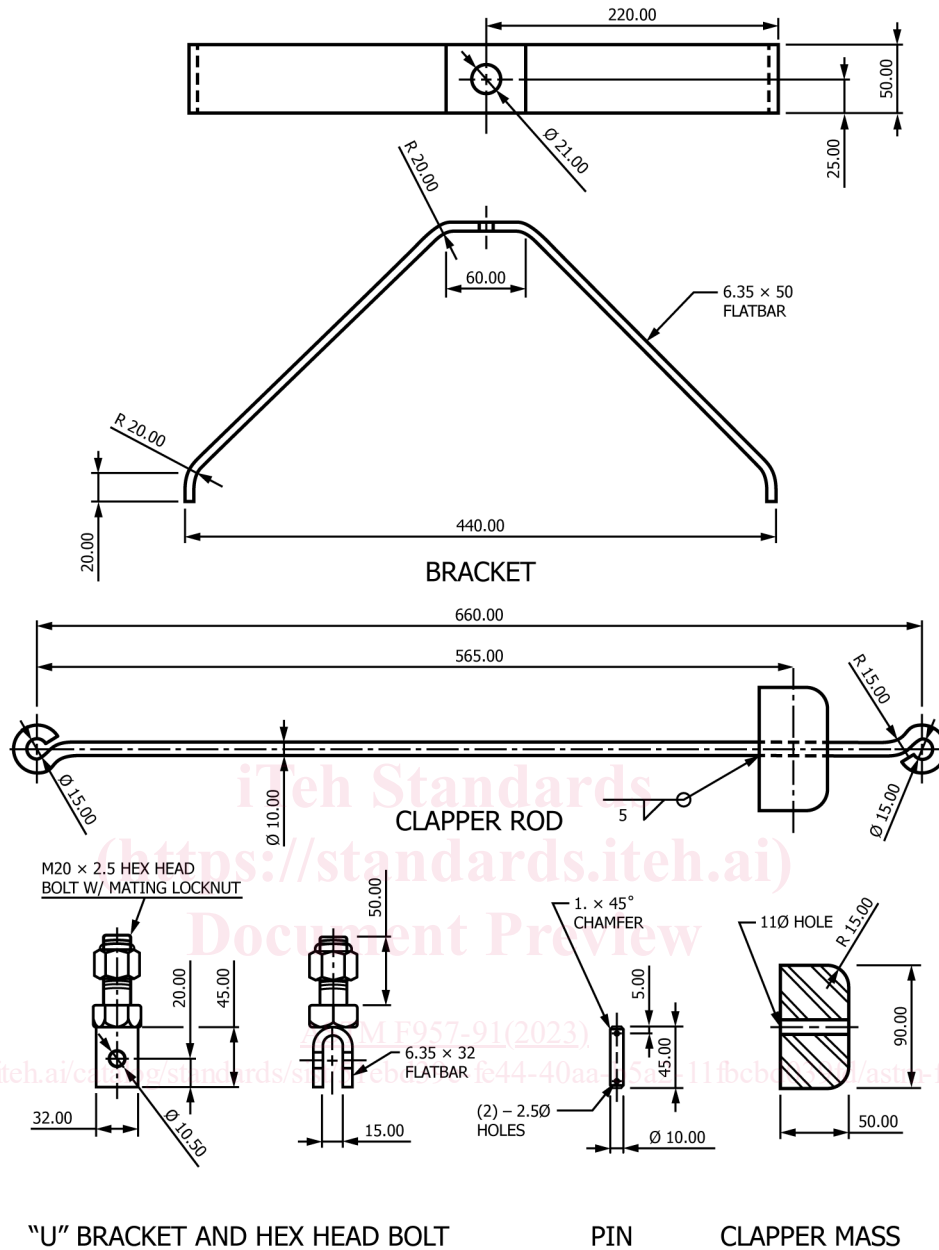

NOTE 1—All dimensions in millimetres.

FIG. 2 Miscellaneous Details

8.2 For orders of 3 to 10 gongs, 2 gongs shall be selected at random. If any one of them fails to meet requirements, then all gongs in the order shall be inspected and tested.

8.3 For orders of more than 10 gongs, they shall be separated into groups of 10 (or fraction thereof) for sampling purposes.

## 9. Inspection and Testing

9.1 *Responsibility*—Unless otherwise specified in the purchase order, the manufacturer shall be responsible for the performance of all inspection and testing specified herein. The manufacturer may utilize his own facilities or any commercial facility acceptable to the purchaser. The purchaser reserves the

right to perform any of the inspections and tests set forth where such are deemed necessary to ensure that supplies conform to prescribed requirements. Nonconforming gongs shall not be offered for delivery.

9.2 *Inspection*—The dimensions of the gong and its components shall be checked to ensure that they are within specified tolerances.

9.3 *Acoustic Test*—Each gong tested shall be supported as shown in Fig. 1 with the clapper in place. The gong shall be rung by striking the cylinder with the clapper, activated by a lanyard. The sound, produced in accordance with Appendix X1, shall be measured in a space with no large sound reflecting