



Designation: C692 – 13 (Reapproved 2023)

# Standard Test Method for Evaluating the Influence of Thermal Insulations on External Stress Corrosion Cracking Tendency of Austenitic Stainless Steel<sup>1</sup>

This standard is issued under the fixed designation C692; the number immediately following the designation indicates the year of original adoption or, in the case of revision, the year of last revision. A number in parentheses indicates the year of last reapproval. A superscript epsilon ( $\epsilon$ ) indicates an editorial change since the last revision or reapproval.

## 1. Scope

1.1 This test method covers two procedures for the laboratory evaluation of thermal insulation materials to determine whether they contribute to external stress corrosion cracking (ESCC) of austenitic stainless steel due to soluble chlorides within the insulation. This laboratory procedure is not intended to cover all of the possible field conditions that contribute to ESCC.

1.2 While the 1977 edition of this test method (Dana test) is applicable only to wicking-type insulations, the procedures in this edition are intended to be applicable to all insulating materials, including cements, some of which disintegrate when tested in accordance with the 1977 edition. Wicking insulations are materials that wet through and through when partially (50 % to 75 %) immersed in water for a short period of time (10 min or less).

1.3 These procedures are intended primarily as a preproduction test for qualification of the basic chemical composition of a particular manufacturer's product and are not intended to be routine tests for ongoing quality assurance or production lot compliance. Test Methods C871, on the other hand, is used for confirmation of acceptable chemical properties of subsequent lots of insulation previously found acceptable by this test method.

1.4 The values stated in inch-pound units are to be regarded as standard. The values given in parentheses are mathematical conversions to SI units that are provided for information only and are not considered standard.

1.5 *This standard does not purport to address all of the safety concerns, if any, associated with its use. It is the responsibility of the user of this standard to establish appropriate safety, health, and environmental practices and determine the applicability of regulatory limitations prior to use.*

<sup>1</sup> This test method is under the jurisdiction of ASTM Committee C16 on Thermal Insulation and is the direct responsibility of Subcommittee C16.31 on Chemical and Physical Properties.

Current edition approved May 1, 2023. Published June 2023. Originally approved in 1971. Last previous edition approved 2018 as C692 – 13 (2018). DOI: 10.1520/C0692-13R23.

1.6 *This international standard was developed in accordance with internationally recognized principles on standardization established in the Decision on Principles for the Development of International Standards, Guides and Recommendations issued by the World Trade Organization Technical Barriers to Trade (TBT) Committee.*

## 2. Referenced Documents

### 2.1 ASTM Standards:<sup>2</sup>

A240/A240M Specification for Chromium and Chromium-Nickel Stainless Steel Plate, Sheet, and Strip for Pressure Vessels and for General Applications

A370 Test Methods and Definitions for Mechanical Testing of Steel Products

C168 Terminology Relating to Thermal Insulation

C795 Specification for Thermal Insulation for Use in Contact with Austenitic Stainless Steel

C871 Test Methods for Chemical Analysis of Thermal Insulation Materials for Leachable Chloride, Fluoride, Silicate, and Sodium Ions

G30 Practice for Making and Using U-Bend Stress-Corrosion Test Specimens

## 3. Terminology

3.1 *Definitions:* Refer to Terminology C168 for definitions relating to insulation.

## 4. Summary of Test Method

4.1 The procedures in this test method consist of using a specimen of insulation to conduct distilled (or deionized) water by wicking or dripping to an outside surface, through the insulation, to a hot inner surface of stressed Type 304 stainless steel for a period of 28 days. If leachable chlorides are present, they are carried along with the water and concentrated at the hot surface by evaporation in much the same way as has been experienced in actual industrial process situations.

<sup>2</sup> For referenced ASTM standards, visit the ASTM website, www.astm.org, or contact ASTM Customer Service at service@astm.org. For *Annual Book of ASTM Standards* volume information, refer to the standard's Document Summary page on the ASTM website.

4.2 Exposed stainless steel coupons are examined visually, and under 10× to 30× magnification, if necessary, to detect ESCC after the prescribed period of exposure.

## 5. Significance and Use

5.1 An inherent characteristic of some alloys of austenitic stainless steel is their tendency to crack at stress points when exposed to certain corrosive environments. The mechanisms of ESCC are complex and not completely understood but are apparently related to certain metallurgical properties. Chloride and fluoride ions have the potential to induce stress corrosion cracking in the absence of inhibiting ions.<sup>3</sup>

5.2 Chlorides are common to many environments, so great care shall be taken to protect austenitic stainless steel from chloride contamination.

5.3 Most thermal insulations will not, of themselves, cause stress corrosion cracking. Preproduction qualification tests are used to evaluate that under the conditions of the laboratory test that specific thermal insulation materials do not cause cracking of sensitized austenitic stainless steel. Insulation systems have the potential to act as collecting media by means of transmigration and concentration of corrosive ions on heated stainless steel surfaces. Exposure to elevated temperature results in evaporation of water and increased chemical reaction rates. Environments containing corrosive ions, moisture, and oxygen will increase the chance for stress corrosion cracking.

5.4 Insulation materials are available that are specially formulated to inhibit stress corrosion cracking in the presence of chlorides through modifications in basic composition or incorporation of certain chemical additives.

5.5 The ability of the 28-day test to measure the corrosion potential of insulation materials is documented by Karnes,<sup>4</sup> whose data appear to have been used for construction of the acceptability curve used in Specification C795 and other specifications.

5.6 The metal for all of the coupons used in this test method (C692) shall be qualified (see Section 14) to ascertain that under conditions of the test, chloride ions will cause the metal to crack, and deionized water alone will not cause cracks.

## 6. Applicability (see also 11.2)

6.1 While the original test procedure for the 1977 edition of this test method (Dana Test) was limited to “wicking-type insulations,” the “drip test procedure” given in this edition is applicable to all insulations when cut or formed into the required test specimen.

6.2 Heat treatment at some temperature (as recommended by the manufacturer) up to the maximum use temperature is

sometimes necessary to make the insulating material “wick,” and thus testable by either insulation test procedure (see Sections 12 and 13).

6.3 If the test insulation cannot be made to wick in any way (such as in the case of organic or inorganic closed-cell foams), or when heat treatment of a component of the insulation (such as an attached exterior jacket material) exceeds the manufacturer’s recommended maximum temperature for the exterior component, then the 1½ in. (38 mm) wide test specimen is sliced into two ¾ in. (19 mm) thick segments. The two halves are held together with wire, pins, or a rubber band, and are tested by dripping into the crack between the two halves, thus simulating the situation where water penetrates the junction between two sections of insulation. Wetting the mating faces on the two half sections facilitates water wicking down to the coupon surface.

6.4 Adhesives are tested by gluing together a test block of the insulation material to be used with the adhesive. The adhesive joint must come into contact with the stainless steel test coupon.

6.5 Cements with a clay binder are tested by casting a 1½ in. (38 mm) thick slab, drying, and using the drip procedure. Such a sample will disintegrate in the Dana test procedure.

6.6 The drip procedure has the potential to be used for the testing of coatings applied to the coupon prior to test. The corrosive liquids dripped into such a system are limited only by the imagination of the researcher.

## 7. Apparatus for Dana Test Procedure

7.1 *Enclosure*—In dusty environments, it is permissible for the test apparatus to be located in a cabinet or other closed structure provided with a blower to maintain a positive internal pressure, and equipped with a filter for intake air to minimize dust or other contamination. The test apparatus is normally housed in any suitable clean environment not subject to chloride contamination. The enclosure shall not be so tight as to exclude oxygen from the system, since oxygen is necessary for ESCC to occur.

7.2 *Pyrex Glass Wool.*

7.3 “*Cookie Cutter*,” made from 1¼ in. (32 mm) thin wall electrical conduit (inside diameter 1.38 in. (35 mm)) to cut a 1⅜ in. (35 mm) diameter plug from 2 in. (51 mm) Pyrex Glass Wool.

7.4 *Specimen Holder*, as shown in Fig. 1, or equivalent.

7.5 *Precision Bender*, see Practice G30.

7.6 *Wet-Grinding Belt Grinder*, 80-grit.

7.7 *Copper Lugs*, commercial 2/0–4/0 solderless, or 2 in. by ½ in. by ⅛ in. (51 mm by 13 mm by 3.2 mm) copper tabs.

7.8 *Silver Solder*, and chloride-free flux for use with stainless steel.

7.9 *Torch*, acetylene or propane.

7.10 *Bolt*, stainless steel, ⅜ in. (5 mm) in diameter and 2½ in. (65 mm) long with insulating washer and nut for electrically insulating the bolt from the U-bend specimen.

<sup>3</sup> Whorlow, Kenneth M., Woolridge, Edward and Hutto, Francis B., Jr., “Effect of Halogens and Inhibitors on the External Stress Corrosion Cracking of Type 304 Austenitic Stainless Steel”; *STP 1320 Insulation Materials: Testing and Applications*, Third Volume, Ronald S. Graves and Robert R. Zarr, editors, ASTM West Conshohocken, PA, 1997 page 485

<sup>4</sup> Karnes, H. F., “The Corrosion Potential of Wetted Thermal Insulation,” AICHE, 57th National Meeting, Minneapolis, MN, September 26 through 29, 1965.

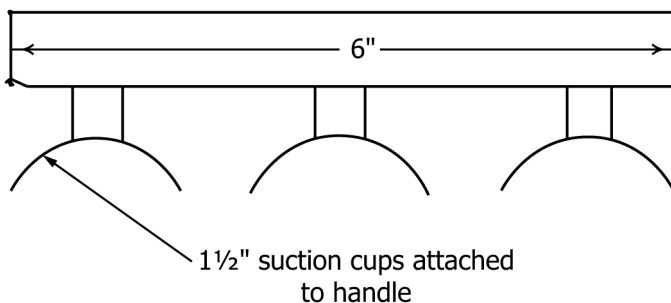

FIG. 1 Suction Cup Coupon Holder

7.11 *Hand-Held Magnifier*, 10× or 30× binocular microscope, or both.

7.12 *Band Saw*.

7.13 *Hole Saw*, 2 in. (51 mm) outside diameter (optional).

7.14 *Crystallizing Dish*, of borosilicate glass, 7½ in. (190 mm) in diameter by 4 in. (100 mm) in depth, or stainless steel pan 9½ in. by 5½ in. by 4 in. (41 mm by 140 mm by 102 mm) deep.

7.15 *Electrical Transformer*, isolation-type. (approximately 150 mV/150 AMP).

7.16 *Thermocouple*, 28 gauge or smaller.

7.17 *Epoxy Adhesive*, aluminum filled.

7.18 *Drill Bit*, ⅜ in. (7 mm), cobalt steel preferred.

7.19 *Dye Penetrant and Developer*, available at most welding supply houses.

## 8. Apparatus for Drip Test Procedure

8.1 *Steam Heated Pipe*—A 5 ft (1.5 m) section of 1½ in. IPS pipe (inconel or other corrosion-resistant material), is heated either by a small self-contained steam boiler or by regulated house steam.

8.2 *Peristaltic Pump*—A multichannel peristaltic pump is used to supply 250 (±25) mL/day to each specimen.



FIG. 2 Typical External Stress Corrosion Cracks (5× Magnification)

8.3 *I.V. Bottles*, 1 L or equivalent, to individually supply each test specimen with test liquid.

8.4 *Specimen Holder*, for grinding. See Fig. 1.

8.5 *Precision Bender*, see Fig. 2 in the 1979 edition of Practice G30.

8.6 *Wet-Sanding Belt Sander*, with 80-grit belt.

8.7 *Bolt*, stainless steel, ⅜ in. (5 mm) in diameter by 2½ in. (65 mm) long with nut.

8.8 *Hole Saw*, 2 in. (51 mm) outside diameter.

8.9 *Band Saw*.

8.10 *Thermocouple*, 28 gauge or smaller.

8.11 *Heat Transfer Grease*, chloride free.

8.12 *Kimwipe Tissue*,<sup>5</sup> chloride free.

## 9. Reagents and Materials

9.1 *Distilled or Deionized Water*, containing less than 0.1 ppm chloride ions.

9.2 *Distilled or Deionized Water*, containing 1500 ppm chloride ion (2.473 g NaCl/L).

9.3 *Type 304 Stainless Steel Sheet*—16 gauge, meeting the composition requirements of Specification A240/A240M. Certificates of chemical composition and mechanical properties, including ultimate tensile strength and yield strength by the 0.2 % offset method are required. Type 304 stainless steel meeting Specification A240/A240M shall have a carbon content in the range of 0.05 %–0.06 % and shall be solution-annealed.

## 10. Test Coupons

10.1 Shear 2 in. by 7 in. (51 mm by 178 mm) coupons from 16 gauge Type 304 stainless sheet, as specified in 9.3, with the long dimension parallel to the long dimension of the sheet. (Long dimension parallel to sheet-rolling direction.)

10.2 Clean coupons with chloride-free liquid soap and water to remove any grease or other contamination.

10.3 Sensitize all coupons before bending by heating at 1200 °F (649 °C) in an argon (inert) or air (oxidizing) atmosphere for three hours. Let cool in the furnace after the sensitizing period.<sup>6</sup> Temperature of the coupons must be measured in the stack of coupons, not in the furnace itself, as the coupon temperatures “lag” the furnace temperature by at least 50 °F to 100 °F (28 °C to 56 °C).

10.4 A suggestion for sensitizing in an inert atmosphere is to use a stainless steel box with a tight-fitting cover to contain the argon around the coupons during sensitization.

10.5 Grip coupon with suction cup holder (see Fig. 1) or other means to facilitate wet grinding on an 80-grit belt grinder. Grind parallel to the long dimension of the coupon using an

<sup>5</sup> Kimwipe is a trademarked product of Kimberly-Clark Corp., Roswell, GA.

<sup>6</sup> For a discussion of the effect of sensitizing stainless steel and its susceptibility to stress corrosion, refer to “Stress-Corrosion Cracking of Sensitized Stainless Steel in Oxygenated High Temperature Water,” Batelle Columbus Laboratories, Report No. BMI 1927, June 1972.

80-grit wet belt with just enough pressure to remove the dull finish and leave the metal bright. Do not overgrind. The beltground face is the test surface to be exposed to the thermal insulation. The test area is the bent coupon surface that actually comes into contact with the insulation.

10.6 Smooth and round sheared edges to prevent accidental cutting of fingers.

10.7 Bend each ground coupon to a 1.00 in.  $\pm$  0.01 in. (25.4 mm  $\pm$  0.25 mm) outside radius using a roll bender as shown in Fig. 5 of the 1979 edition of Practice G30 to produce a U-shape in which the “legs” are parallel to within  $\frac{1}{16}$  in. (1.6 mm).

10.8 Drill or punch a  $\frac{3}{32}$  in. (7 mm) hole in each end using the special jig shown in Fig. 3. Cobalt steel drill bits are used on 304 stainless steel as other bits dull quickly.

10.9 For the Dana test only, silver-solder a 2/0–4/0 solderless copper electrical connector to each leg with the hole in the connector centered on the drilled hole. While it has been conventional to solder one lug to an inside surface and the second to an outside surface, it is acceptable to solder both to outside surfaces for greater convenience. The body of the coupon is shielded from high soldering temperatures by placing a soaking-wet chloride-free cellulose pad on the coupon next to the weld area to act as a heat sink. Carefully remove all flux from the finished coupon by washing with hot water. The contact surfaces of the copper connector is cleaned by sanding, wire brush, or other means to avoid electrical contact problems.

10.9.1 As an alternate to the 2/0–4/0 solderless lug, 2 in. by  $\frac{1}{2}$  in. by  $\frac{1}{8}$  in. (50.8 mm by 13 mm by 3.2 mm) copper lugs are silver-soldered to diagonally opposite outside corners leaving exactly half of each sticking out from the test coupon for the electrical hookup. Test data have shown this simpler lug to be equivalent to the commercial 2/0–4/0 lug.

10.10 Clean the convex surface to be tested with chloride-free cleansing powder and a cotton swab or chloride-free cellulose pad (such as Kimwipe<sup>5</sup> or equivalent) soaked in distilled or deionized water. Rinse in distilled or deionized water, and air dry. Do not touch the convex test surface with bare hands thereafter.

10.11 Obtain the value of the yield strength and the modulus of elasticity from the certified statement of mechanical properties for the particular sheet of stainless steel or from tensile tests conducted in accordance with Test Methods and Definitions A370. Make the necessary measurements on each test specimen and calculate the leg deflection required to produce the desired elastic stress using the formula shown in Fig. 4. The desired elastic stress for this test method is 30 000 psi.

10.12 Utilizing the value for sigma determined in 10.11, calculate the number of turns of the nut necessary to achieve the proper stress by dividing sigma by the distance between threads. The leg deflection is also conveniently measured using a Vernier caliper.

10.13 Install bolt and nut (and washer for Dana test) on each coupon and run the nut up snug without bending the coupon.

10.14 Holding the head of the screw with a screwdriver, turn the nut the required number of turns as calculated in 10.12, or measure the leg deflection with a Vernier caliper.

10.15 For the Dana test only, as a last step before running the test, attach a 28 gauge (or smaller) thermocouple to the inside middle of the coupon using aluminum-filled epoxy. The head of the thermocouple must be in contact with the coupon to get an accurate measure of coupon temperature.

10.16 Before use, the lot of sensitized coupons shall be qualified using the procedure described in Section 14.

## 11. Sample Preparation

11.1 If there is any reason to believe that the surface of an insulating material is different from the interior, the material shall be tested in such a manner as to test what is judged to be the most sensitive portion.

11.2 Procedure for materials in which the surfaces and interior are considered totally uniform in properties, including but not limited to foam insulation cut from “buns,” Foamglas, loose-fill insulation, man-made mineral-fiber block and board, and perlite insulation:

11.2.1 Cut insulation specimens into 4 in. by 7 in. by  $1\frac{1}{2}$  in. (102 mm by 178 mm by 38 mm) sections and drill a 2 in. (51 mm) hole in the center of each with an appropriate hole saw. Cut the specimen in half to produce two test specimens that measure 4 in. by  $3\frac{1}{2}$  in. by  $1\frac{1}{2}$  in. (102 mm by 89 mm by 38 mm) as shown in Fig. 5a.

11.2.2 Carefully fit each insulation block to its coupon by sanding with clean, chloride-free sandpaper if necessary to achieve a perfect fit. Air blow the prepared test specimen to remove dust.

11.2.3 Loose-fill materials are tested by fabricating a “cage” from stainless steel wire mesh in the shape of the test specimen shown in Fig. 5a. Stuff the loose fill material into the cage at the intended use density.

11.2.4 Thin layers of insulating material are tested by “stacking” to achieve a  $1\frac{1}{2}$  in. (38 mm) stack and then proceeding as directed in 11.2.1 above, holding the final test stack in place with a rubber band, wire, or straight pins.

11.3 Procedure for materials that have outer surfaces that differ from inner surfaces, including but not limited to: (1)

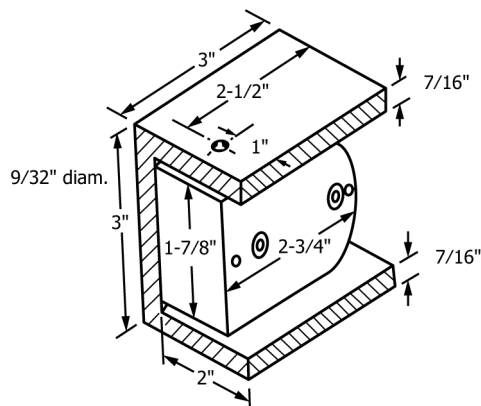
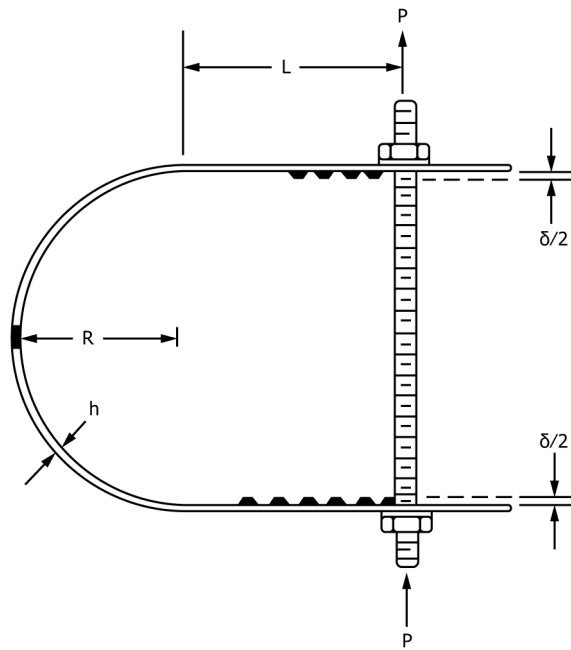

FIG. 3 Jig for Positioning Holes in the U-Bend Specimen



$$\delta \text{ in.} = \left[ \frac{12S(2R+h)}{(L+R)(8R+h)(h)(E)} \right] \cdot \left[ \frac{L^3}{3} + R \left( \frac{\pi}{2} L^2 + \frac{\pi}{4} R^2 + 2LR \right) \right]$$

where:

- $\delta$  = deflection, in.,
- $S$  = applied stress, psi,
- $E$  = modulus of elasticity,
- $R$  = radius of bend, in.,
- $h$  = thickness, in., and
- $L$  = length of straight section, in.

**FIG. 4 Measurements Required for Post-Tensioning Deflection Calculations on U-Bend Test Specimens**

<https://standards.iteh.ai/catalog/standards/sist/1f55ca45-653d-4fcb-900d-37f8da14ea7c/astm-c692-132023>

wet-process materials where soluble ions migrate to the outer surface during drying including calcium silicate and insulating cements, (2) fiberglass that has been rolled on a mandrel to form pipe cover using a mandrel release agent, and (3) mineral wool that has been V-grooved and glued to form pipe cover.

11.3.1 Cut the test specimens from 1.5 N 2.5 ( $\pm 0.5$  in. thickness) pipe insulation, including jacketing (see the exception stated in 6.3) if it is attached to the insulation, as shown in Fig. 5b. Air blow the prepared test specimen to remove dust. When necessary for special situations or research projects it is permissible to cut the test specimen from other pipe sizes or elbows. Maintain as much of the inner surface in a proportion as to be representative of the original material. It shall be stated in the test report that a nonstandard size was used for the fabrications.

11.3.2 In the case of insulating cement, form the test piece around a bent coupon until set and then take out of the form for final drying. Since some cements do not readily wick water, samples made from such materials shall be split before testing to allow the DI water to penetrate down to the test coupon (Drip procedure only).

11.4 Choice of test procedure: (1) If the material readily wicks water, it is tested by either the Dana or the Drip

procedure. (2) If the material will wick readily after heat treatment (for example, heating perlite insulation to destroy the hydrophobicity of the material), it is tested by either test procedure. (See the exception stated in 6.3.) (3) If the material cannot be made to wick, it shall be tested by the Drip procedure.

11.4.1 An unwettable block material is split, with the two halves held together with a rubber band, pin, or wire for test. If the split surfaces cannot be wet in any way, they are parted slightly to allow the DI water to penetrate down to the test coupon.

11.4.2 If the “stacked” material in 11.2.4 will not wick, it shall be tested by the Drip procedure, wetting or slightly separating the layers to allow the DI water to penetrate to the test coupon.

## 12. Procedure A (Dana Test)

12.1 Place each specimen of thermal insulation in a crystallizing dish (or stainless steel alternate) with the U-shaped groove up, connect the stainless steel U-bend coupons electrically in series, and place in position within the cavity in the insulation specimen.