



Designation: C1869 – 18 (Reapproved 2023)

Standard Test Method for Open-Hole Tensile Strength of Fiber-Reinforced Advanced Ceramic Composites¹

This standard is issued under the fixed designation C1869; the number immediately following the designation indicates the year of original adoption or, in the case of revision, the year of last revision. A number in parentheses indicates the year of last reapproval. A superscript epsilon (ϵ) indicates an editorial change since the last revision or reapproval.

1. Scope

1.1 This test method determines the open-hole (notched) tensile strength of continuous fiber-reinforced ceramic matrix composite (CMC) test specimens with a single through-hole of defined diameter (either 6 mm or 3 mm). The open-hole tensile (OHT) test method determines the effect of the single through-hole on the tensile strength and stress response of continuous fiber-reinforced CMCs at ambient temperature. The OHT strength can be compared to the tensile strength of an unnotched test specimen to determine the effect of the defined open hole on the tensile strength and the notch sensitivity of the CMC material. If a material is notch sensitive, then the OHT strength of a material varies with the size of the through-hole. Commonly, larger holes introduce larger stress concentrations and reduce the OHT strength.

1.2 This test method defines two baseline OHT test specimen geometries and a test procedure, based on Test Methods C1275 and D5766/D5766M. A flat, straight-sided ceramic composite test specimen with a defined laminate fiber architecture contains a single through-hole (either 6 mm or 3 mm in diameter), centered by length and width in the defined gage section (Fig. 1). A uniaxial, monotonic tensile test is performed along the defined test reinforcement axis at ambient temperature, measuring the applied force versus time/displacement in accordance with Test Method C1275. Measurement of the gage length extension/strain is optional, using extensometer/displacement transducers. Bonded strain gages are optional for measuring localized strains and assessing bending strains in the gage section.

1.3 The open-hole tensile strength (S_{OHTx}) for the defined hole diameter x (mm) is the calculated ultimate tensile strength based on the maximum applied force and the gross cross-sectional area, disregarding the presence of the hole, per common aerospace practice (see 4.4). The net section tensile

strength (S_{NSx}) is also calculated as a second strength property, accounting for the effect of the hole on the cross-sectional area of the test specimen.

1.4 This test method applies primarily to ceramic matrix composites with continuous fiber reinforcement in multiple directions. The CMC material is typically a fiber-reinforced, 2-D, laminated composite in which the laminate is balanced and symmetric with respect to the test direction. Composites with other types of reinforcement (1-D, 3-D, braided, unbalanced) may be tested with this method, with consideration of how the different architectures may affect the notch effect of the hole on the OHT strength and the tensile stress-strain response. This test method does not directly address discontinuous fiber-reinforced, whisker-reinforced, or particulate-reinforced ceramics, although the test methods detailed here may be equally applicable to these composites.

1.5 This test method may be used for a wide range of CMC materials with different reinforcement fibers and ceramic matrices (oxide-oxide composites, silicon carbide (SiC) fibers in SiC matrices, carbon fibers in SiC matrices, and carbon-carbon composites) and CMCs with different reinforcement architectures. It is also applicable to CMCs with a wide range of porosities and densities.

1.6 Annex A1 and Appendix X1 address how test specimens with different geometries and hole diameters may be prepared and tested to determine how those changes will modify the OHT strength properties, determine the notch sensitivity, and affect the stress-strain response.

1.7 The test method may be adapted for elevated temperature OHT testing by modifying the test equipment, specimens, and procedures per Test Method C1359 and as described in Appendix X2. The test method may also be adapted for environmental testing (controlled atmosphere/humidity at moderate (<300 °C) temperatures) of the OHT properties by the use of an environmental test chamber, per 7.6.

1.8 Values expressed in this test method are in accordance with the International System of Units (SI) and IEEE/ASTM SI 10.

1.9 This standard does not purport to address all of the safety concerns, if any, associated with its use. It is the

¹ This test method is under the jurisdiction of ASTM Committee C28 on Advanced Ceramics and is the direct responsibility of Subcommittee C28.07 on Ceramic Matrix Composites.

Current edition approved May 1, 2023. Published June 2023. Originally approved in 2018. Last previous edition approved in 2018 as C1869 – 18. DOI: 10.1520/C1869-18R23.

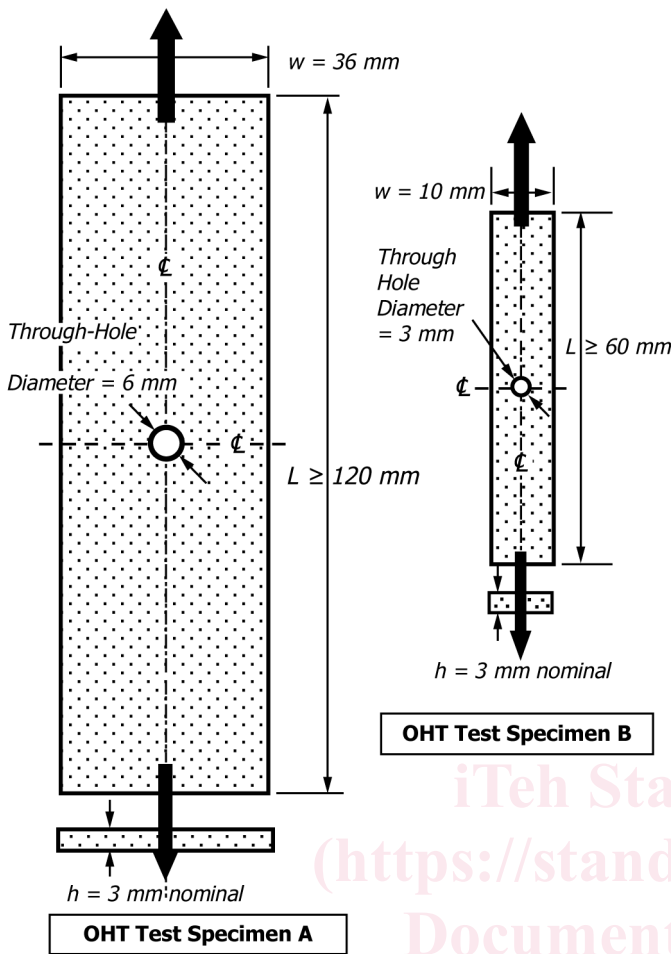

FIG. 1 OHT Test Specimens A and B

- C1239 Practice for Reporting Uniaxial Strength Data and Estimating Weibull Distribution Parameters for Advanced Ceramics
- C1275 Test Method for Monotonic Tensile Behavior of Continuous Fiber-Reinforced Advanced Ceramics with Solid Rectangular Cross-Section Test Specimens at Ambient Temperature
- C1326 Test Method for Knoop Indentation Hardness of Advanced Ceramics
- C1327 Test Method for Vickers Indentation Hardness of Advanced Ceramics
- C1359 Test Method for Monotonic Tensile Strength Testing of Continuous Fiber-Reinforced Advanced Ceramics With Solid Rectangular Cross Section Test Specimens at Elevated Temperatures
- C1465 Test Method for Determination of Slow Crack Growth Parameters of Advanced Ceramics by Constant Stress-Rate Flexural Testing at Elevated Temperatures
- C1773 Test Method for Monotonic Axial Tensile Behavior of Continuous Fiber-Reinforced Advanced Ceramic Tubular Test Specimens at Ambient Temperature
- C1793 Guide for Development of Specifications for Fiber Reinforced Silicon Carbide-Silicon Carbide Composite Structures for Nuclear Applications
- D3039/D3039M Test Method for Tensile Properties of Polymer Matrix Composite Materials
- D3878 Terminology for Composite Materials
- D5766/D5766M Test Method for Open-Hole Tensile Strength of Polymer Matrix Composite Laminates
- D6856/D6856M Guide for Testing Fabric-Reinforced “Textile” Composite Materials
- E4 Practices for Force Calibration and Verification of Testing Machines
- E6 Terminology Relating to Methods of Mechanical Testing
- E83 Practice for Verification and Classification of Extensometer Systems
- E105 Guide for Probability Sampling of Materials
- E122 Practice for Calculating Sample Size to Estimate, With Specified Precision, the Average for a Characteristic of a Lot or Process
- E251 Test Methods for Performance Characteristics of Metallic Bonded Resistance Strain Gages
- E337 Test Method for Measuring Humidity with a Psychrometer (the Measurement of Wet- and Dry-Bulb Temperatures)
- E691 Practice for Conducting an Interlaboratory Study to Determine the Precision of a Test Method
- E1012 Practice for Verification of Testing Frame and Specimen Alignment Under Tensile and Compressive Axial Force Application
- E1402 Guide for Sampling Design
- E2208 Guide for Evaluating Non-Contacting Optical Strain Measurement Systems
- IEEE/ASTM SI 10 American National Standard for Metric Practice

3. Terminology

3.1 *Definitions*—Annex A2 lists pertinent general definitions from Practice E1012, Terminology C1145 (advanced

responsibility of the user of this standard to establish appropriate safety, health, and environmental practices and determine the applicability of regulatory limitations prior to use.

1.10 This international standard was developed in accordance with internationally recognized principles on standardization established in the Decision on Principles for the Development of International Standards, Guides and Recommendations issued by the World Trade Organization Technical Barriers to Trade (TBT) Committee.

2. Referenced Documents

2.1 ASTM Standards:²

- C373 Test Methods for Determination of Water Absorption and Associated Properties by Vacuum Method for Pressed Ceramic Tiles and Glass Tiles and Boil Method for Extruded Ceramic Tiles and Non-tile Fired Ceramic Whiteware Products
- C1145 Terminology of Advanced Ceramics

² For referenced ASTM standards, visit the ASTM website, www.astm.org, or contact ASTM Customer Service at service@astm.org. For Annual Book of ASTM Standards volume information, refer to the standard’s Document Summary page on the ASTM website.

ceramics), Terminology **D3878** (composite materials), and Terminology **E6** (tensile testing), with the appropriate source given in bold font.

3.2 *Definitions of Terms Specific to This Standard:*

3.2.1 If the term represents a physical quantity, its analytical dimensions are stated immediately following the term (or letter symbol) in fundamental dimension form, using the following ASTM standard symbology for fundamental dimensions, shown within square brackets: [M] for mass, [L] for length, [T] for time, [θ] for thermodynamic temperature, and [nd] for nondimensional quantities. Use of these symbols is restricted to analytical dimensions when used with square brackets, as the terms may have other definitions when used without the brackets.

3.2.2 *diameter-to-thickness ratio (D/h), [L/L], n—in an open-hole tensile specimen, the ratio of the hole diameter (D) to the specimen thickness (h).*

3.2.2.1 *Discussion*—The diameter-to-thickness ratio may be either a nominal value determined from nominal dimensions or an actual value determined from measured dimensions.

3.2.3 *failure strength, n*—the strength parameter (stress, torque, moment, force, etc.) that produces material failure in a given test specimen in a given stress state and test orientation.

3.2.3.1 *Discussion*—In mechanical testing of ceramic composites, failure is often defined by a total or partial loss of load carrying capacity, marked by the breaking or tearing apart of or damage to the test specimen (synonym—*rupture*). Failure strength is typically defined for a given stress state (tensile, compression, shear, flexure, torsion) and a given test orientation in the test specimen.

3.2.4 *material failure, n—in mechanical testing, the loss of or inability to meet the required load carrying capacity specified in the applicable material or performance requirement, depending on the purpose of the test.*

3.2.5 *net section tensile strength (S_{NSx}), [FL⁻²], n—in the open-hole tensile test, the hole-diameter-adjusted maximum tensile stress which the OHT test specimen (with a through-hole of defined diameter x (mm)) is capable of sustaining. The net section tensile strength is calculated from the maximum force during the OHT test carried to failure/rupture and the reduced cross-sectional area of the specimen, considering the presence of the hole.*

3.2.6 *open-hole (notched) tensile strength (S_{OHTx}), [FL⁻²], n—in the open-hole tensile test, the maximum tensile stress that the OHT test specimen (with a through-hole of defined diameter x (mm)) is capable of sustaining. The OHT strength is calculated from the maximum force during the OHT test carried to failure/rupture and the original/gross cross-sectional area of the specimen, disregarding the presence of the hole.*

3.2.6.1 *Discussion*—While the hole causes a stress concentration and reduced net section, it is common aerospace practice (per Test Method **D5766/D5766M**) to develop notched-design allowable strengths, based on gross section stress, to account for various stress concentrations (fastener holes, free edges, flaws, damage, and so forth) not explicitly modeled in the stress analysis. This gross section stress is also called the “remote stress.”

3.2.7 *principal structural axis, n—in a composite flat plate or rectangular bar, the composite coordinate axis/direction with the maximum in-plane Young’s modulus (based on Terminology **D3878**). This is commonly the axis with the highest fiber fraction or the warp direction of the weave.*

3.2.8 *test reinforcement axis alignment, n*—the orientation/alignment of the long tensile test axis of the test specimen with respect to the principal structural axis.

3.2.8.1 *Discussion*—In composite testing, it is common practice to test specimens with different test axis alignments (0°, 90°, ±45° to the principal structural axis) to determine the mechanical properties in the different anisotropic directions. (See **Fig. 2**.)

3.2.9 *width-to-diameter ratio (w/D), [L/L]—in an open-hole tensile specimen, the ratio of the specimen width (w) to the hole diameter (D).*

3.2.9.1 *Discussion*—The width-to-diameter ratio may be either a nominal value determined from nominal dimensions or an actual value determined from measured dimensions.

3.3 *Symbols:*

3.3.1 *A*—gross cross-sectional area of the test specimen, disregarding the presence of the through-hole (mm²)

3.3.2 *A_{NS}*—net cross-sectional area of the test specimen, considering the presence of the through-hole (mm²)

3.3.3 *CV*—coefficient of variation statistic of a sample population for a given property (in percent)

3.3.4 *D*—diameter of the through-hole (mm)

3.3.5 *h*—test specimen thickness (mm)

3.3.6 *L*—total length of the test specimen (mm)

3.3.7 *L_{gage}*—the nominal gage section length of the test specimen (mm)

3.3.8 *L_{grip}*—grip section length of the test specimen (mm)

3.3.9 *n*—number of valid specimen data points for statistical calculations

3.3.10 *N_T*—total number of test specimens that were tested

3.3.11 *N_V*—number of valid test specimens

3.3.12 *P_{max}*—maximum force carried by test specimen prior to failure (N)

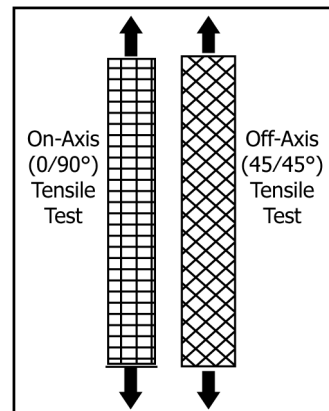

FIG. 2 Test Specimen Alignment

3.3.13 $s.d.$ —standard deviation statistic of a sample population for a given property

3.3.14 S_{NSx} —net section tensile strength in the test direction for a test specimen with a through-hole diameter of x mm (MPa)

3.3.15 S_{OHTx} —ultimate open-hole (notched) tensile strength in the test direction for a test specimen with a through-hole diameter of x mm (MPa)

3.3.16 S_U —ultimate tensile strength of the unnotched (no-hole) test specimen in the test direction (MPa)

3.3.17 w —width of the gage section of the test specimen (mm)

3.3.18 x —diameter of the through-hole in the test specimen (mm)

3.3.19 \bar{X} —mean or average (estimate of mean) of a sample data population for a given property

3.3.20 X_i —test result for an individual specimen from the sample population for a given property

3.3.21 σ —engineering stress (MPa)

3.3.22 σ_o —proportional limit stress (MPa)

4. Summary of Test Method

4.1 A uniaxial tension test is performed on a flat, straight-sided ceramic matrix composite test specimen with a defined fiber architecture and a single through-hole centered in the gage section. Two geometries are defined as a baseline for test specimens: Test Specimen A with a single 6 mm diameter hole centered in the gage section (36 mm by ≥ 60 mm) of the specimen, and Test Specimen B with a single 3 mm diameter hole centered in the gage section (10 mm by ≥ 30 mm) of the specimen. The test specimen is loaded in uniaxial tension, per Test Method **C1275**, along a defined test reinforcement axis at a constant displacement rate at ambient temperature until failure/rupture occurs. The applied force is measured as a function of time/displacement. Measurement of the gage length extension/strain is optional, using extensometer transducers. Bonded strain gages are optional for measuring localized strains and bending strains in the gage section. If measured, extension/strain is recorded against time.

4.2 There are typically two competing mechanisms operating in the stress field around the hole/notch in a ceramic matrix composite: the stress concentration effect of the hole, and the redistribution of stress with the inelastic straining (**1-4**).³ The relative effects of these two mechanisms can vary widely with different CMC materials, depending on the reinforcement architecture, the matrix microstructure, and the stress-strain-damage mechanisms close to the hole. If there is a large amount of inelastic straining and stress redistribution in the CMC, the stress-concentration effect of the hole may be essentially cancelled out and the CMC material will have little or no notch sensitivity.

4.3 If there is some degree of notch sensitivity for a given ceramic matrix composite material, larger holes will generally

³ The boldface numbers in parentheses refer to a list of references at the end of this standard.

produce higher stress concentrations and reduce the tensile strength of the CMC. For this reason, the open-hole tensile (OHT) strength should be qualified by a hole size designator x (in mm), so that the test strength (S_{OHTx}) clearly shows what size hole was tested. (This is similar to how microhardness numbers are identified per the type of indenter—HK = hardness by Knoop indenter (K for Knoop) and HV = hardness by Vickers indenter (V for Vickers), per Test Methods **C1326** and **C1327**.)

4.4 The ultimate open-hole tensile (OHT) strength (S_{OHTx}) is calculated based on the gross cross-sectional area, disregarding the presence of the hole (per Test Method **D5766/D5766M**). While the hole causes a stress concentration and a reduced net section, it is common aerospace practice to develop notched-design allowable strengths based on gross section stress to account for various stress concentrations (fastener holes, free edges, flaws, damage, and so forth) not explicitly modeled in the stress analysis. This gross section stress value is also called the “remote stress.”

4.5 The net section tensile strength (S_{NSx}) is also calculated as a second strength property, considering the hole size. Stress-time/extension plots are of value in determining the effect of the hole on the tensile stress response and fracture modes.

4.6 The only valid failure mode for open-hole tensile strength is one in which the failure/fracture surface passes through the center hole in the test specimen.

4.7 Unnotched tensile specimens of the same geometry should be tested to compare the OHT strength (S_{OHTx}) and net section strength (S_{NSx}) to the “no-notch” tensile strength (S_U).

4.8 The test specimen geometry and hole size may be modified to determine the effect of different specimen geometries, hole sizes, and gage section widths and thicknesses on OHT strength. These modifications are described in **Annex A1** and **Appendix X1**. The test may also be modified for elevated temperature testing with appropriate heating equipment, thermal measurement systems, and modified test procedures (**Appendix X2**).

5. Significance and Use

5.1 Open-hole tests of composites are used for material and design development for the engineering application of composite materials (**5-11**). The presence of an open hole in a composite component reduces the cross-sectional area available to carry an applied force, creates stress concentrations, and creates new edges where delamination may occur. Standardized open-hole tests for composite materials can provide useful information about how a composite material may perform in an open-hole application and how to design the composite for notches and holes.

5.2 The test method defines two baseline test specimen geometries and a test procedure for producing comparable, reproducible OHT test data. The test method is designed to produce OHT strength data for structural design allowables, material specifications, material development and comparison,

material characterization, and quality assurance. The mechanical properties that may be calculated from this test method include:

5.2.1 The open-hole (notched) tensile strength (S_{OHTx}) for test specimen with a hole diameter x (mm).

5.2.2 The net section tensile strength (S_{NSx}) for a test specimen with a hole diameter x (mm).

5.2.3 The proportional limit stress (σ_0) for an OHT specimen with a given hole diameter.

5.2.4 The stress response of the OHT test specimen, as shown by the stress-time or stress-displacement plot.

5.3 Open-hole tensile tests provide information on the strength and deformation of materials with defined through-holes under uniaxial tensile stresses. Material factors that influence the OHT composite strength include the following: material composition, methods of composite fabrication, reinforcement architecture (including reinforcement volume, tow filament count and end-count, architecture structure, and laminate stacking sequence), and porosity content. Test specimen factors of influence are: specimen geometry (including hole diameter, width-to-diameter ratio, and diameter-to-thickness ratio), specimen preparation (especially of the hole), and specimen conditioning. Test factors of influence are: specimen alignment and gripping, speed of testing, and test temperature/environment. Controlled stress states are required to effectively evaluate any nonlinear stress-strain behavior which may develop as the result of cumulative damage processes (for example, matrix cracking, matrix/fiber debonding, delamination, fiber pull-out and fracture, etc.) which may be influenced by testing mode, testing rate, processing effects, or environmental influences. Some of these effects may be consequences of stress corrosion or slow (subcritical) crack growth. Stress corrosion and slow crack growth factors can be minimized by testing at sufficiently rapid rates as described in 12.1.7.

6. Interferences

6.1 *Material and Specimen Preparation*—Inherent variability in constituents and their properties, variation in material fabrication practices, fiber alignment, delamination and internal porosity, and damage induced by improper specimen machining are all known causes of data scatter in ceramic matrix composites.

6.2 *Hole Preparation*—Since the hole/notch dominates the strength, consistent preparation of the hole, without damage to the composite, is important for reproducible, valid results. Variable damage due to hole preparation will affect strength results.

6.3 *Hole Size*—Depending on the degree of notch sensitivity of the CMC material, different hole sizes will have different stress concentrations. Variations in hole size may introduce data scatter in the test results.

6.3.1 One of the factors that must be considered and reported is the relative diameter of the through-hole against the unit cell size of the fabric weave. If the diameter of the through-hole is of the same scale as the fabric unit cell size, the hole stress concentrations may interact with local weave variations to produce complex stress-strain variations. Care should be taken in specimen design such that the hole diameter is not under a fabric unit cell size, unless the test is an analog for a real-world application. In general, effects associated with fabric unit cell size can be minimized by sizing the hole to include at least one and preferably two fabric unit cells in the diameter.

6.4 *Specimen Geometry*—Results may be affected by the ratio of specimen width to the hole diameter (w/D). This ratio shall be maintained at 6 or greater for Test Specimen A and at 3 or greater for Test Specimen B, unless the experiment is investigating the influence of this ratio. Results may also be affected by the specimen thickness and the ratio of hole diameter to thickness (D/h). For Test Specimen A, the nominal D/h ratio is 2. For Test Specimen B, the nominal D/h ratio is 1. But the D/h ratio may vary widely if the experiment is investigating hole size and thickness effects. OHT strength results may also be affected by specimen length and gage section length. Tables 1 and 2 list the recommended specimen lengths and gage lengths for Test Specimen A (120 mm/60 mm) and Test Specimen B (60 mm/30 mm). Shorter specimens may not produce valid fracture through the center hole. Longer specimens may be necessary for certain types of CMC materials, if the nominal specimen lengths do not produce valid fracture through the center hole.

6.5 *Thickness Scaling Effects*—Thick composite structures do not necessarily fail at the same strengths as thin structures with the same laminate orientation (that is, strength does not

TABLE 1 Dimensions and Tolerances for OHT Test Specimen A

Test Specimen A – 6-mm hole in 36-mm wide gage section

Shape and orientation: Flat bar with constant rectangular cross section with a through-hole centered in the gage section. Long tensile test axis is oriented to the designated reinforcement axis (for example, 0°, 90°, ±45°).

Dimensional Feature	Dimensions	Tolerance, Position, and Alignment
D = hole diameter	6.0 mm, w/D ratio = 6	Tolerance = ±0.2 mm for circularity Centered in the gage section (±0.5 mm for width and ±2 mm for length)
w = gage section width	36 mm	Uniform and parallel to ±0.5 mm, ±2 %
L = minimum specimen length	≥120 mm (>20 × D)	No specified tolerance
L_{gage} = gage section length	≥60 mm (>10 × D)	Tolerance = ±2 mm
L_{grip} = grip section length	≥30 mm (~50 % of L_{gage})	No specified tolerance
h = recommended specimen thickness	2 mm ≤ h ≤ 10 mm, 3 mm nominal	No specified tolerance for as-fabricated specimens Parallel and flat by ±2 % for face-machined specimens

TABLE 2 Dimensions and Tolerances for OHT Test Specimen B

Test Specimen B – 3 mm hole in 10 mm wide gage section

Shape and orientation: Flat bar with constant rectangular cross section with a through-hole centered in the gage section. Long tensile test axis is oriented to the designated reinforcement axis (for example, 0°, 90°, ±45°).

Dimensional Feature	Dimensions	Tolerance, Position, and Alignment
D = hole diameter	3.0 mm, w/D ratio = 3.33	Tolerance = ± 0.1 mm for circularity Centered in the gage section (± 0.5 mm for width and ± 2 mm for length)
w = gage section width	10 mm	Uniform and parallel to ± 0.2 mm, $\pm 2\%$
L = minimum specimen length	≥ 60 mm ($> 20 \times D$)	No specified tolerance
L_{gage} = gage section length	≥ 30 mm ($> 10 \times D$)	Tolerance = ± 2 mm
L_{grip} = grip section length	≥ 15 mm ($\sim 50\%$ of L_{gage})	No specified tolerance
h = recommended specimen thickness	$2 \text{ mm} \leq h \leq 10 \text{ mm}$, 3 mm nominal	No specified tolerance for as-fabricated specimens Parallel and flat by $\pm 2\%$ for face-machined specimens

always remain constant and independent of specimen thickness). Thus, data gathered using this test method for a given specimen thickness may not translate directly into equivalent properties for thicker specimens.

6.6 *Material Orthotropy*—The degree of composite orthotropy may strongly affect the failure mode and the measured OHT strength. OHT strength results are valid and shall be reported only when appropriate failure at the center hole is observed, in accordance with 9.11 and 12.5.

6.7 *System Alignment*—Excessive bending stresses in the test specimen will cause premature failure and a misleading or false positive result. Bending may occur as a result of misaligned grips or from specimens themselves (if improperly installed in the grips or from out-of-tolerance dimensions). If there is any doubt as to the alignment of the load train and the test specimen in a given test machine, then the alignment shall be checked and adjusted as discussed in 7.3.

6.8 *Other*—Additional sources of potential interference and data scatter (including slow crack growth, test environment effects, surface preparation, out-of-gage fracture, etc.) in testing of ceramic composite materials are described in Section 5 of Test Method C1275.

7. Apparatus

7.1 The test apparatus (Fig. 3) shall be in accordance with the following sections of Test Method C1275 and cited ASTM mechanical testing references.

7.2 *Testing Machine*—The testing machine applies and measures the force on the test specimen in a controlled manner. A testing machine commonly consists of a test frame, force transducers, and the actuator/drive mechanism. The test machine and its components shall conform to the requirements of 6.1 of Test Method C1275 and Practices E4.

7.2.1 *Gripping Devices*—Gripping devices are used to transmit the measured force to the test specimens and to keep the specimen properly aligned in the load train. Face-gripping devices are commonly used for the flat, straight-sided test specimens defined in this test method. Gripping devices are classed as those employing active or passive grip interfaces. Gripping devices shall meet the requirements specified in 6.2 of Test Method C1275.

7.2.2 *Load Train Couplers*—Various types of load train couplers are used to attach the gripping devices to the testing

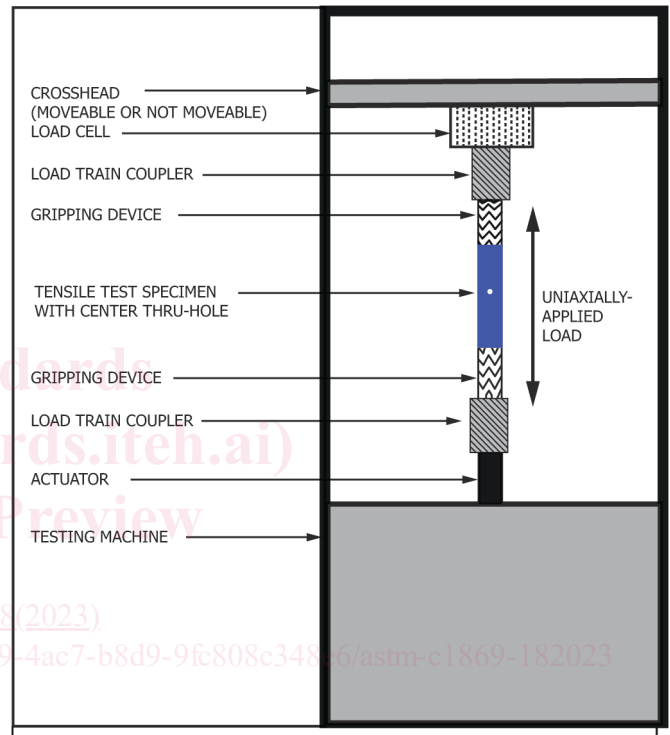

FIG. 3 Tensile Test Apparatus Schematic

machine. The load train couplers, in conjunction with the type of gripping device, play major roles in the alignment of the load train and thus reducing bending imposed in the specimen. Load train couplers are generally classified as fixed and nonfixed. Load train couplers shall meet the requirements specified in 6.3 of Test Method C1275.

7.2.3 *Strain Measurement*—Gage section strain is not a required or typical measurement in the open-hole tensile test, because of the nonuniform strain in the region of the through-hole. Optional strain measurement by extensometer, bonded strain gages, and digital image correlation (DIC) are discussed in Appendix X3.

7.3 *Allowable Bending (Test Methods C1275 and D3039/D3039M and Practice E1012)*—The recommended maximum allowable percent bending for alignment specimens in the load train is five percent (5%) at the onset of the cumulative fracture process (for example, matrix cracking stress). However, it should be noted that unless each individual

specimen is properly strain gaged and percent bending monitored until the onset of the cumulative fracture process, there will be no record of percent bending at the onset of fracture for each specimen. Therefore, the load train alignment should be verified with an alignment specimen using the procedures detailed in 6.5 and Appendix X1 of Test Method C1275, 7.2.5 of Test Method D3039/D3039M, or Appendix X4 of this test method such that percent bending with the alignment specimen does not exceed five percent (5 %) at a mean strain equal to either one-half the anticipated strain at the onset of the cumulative fracture process (for example, matrix cracking stress), or a strain of 0.0005 (that is, 500 microstrain), whichever is greater. Note that percent bending in mounted test specimens may be greater than 5 %, due to variations in the dimensions, flatness, and twist of individual test specimens. If test specimens are measured for percent bending, the recommended limit for percent bending in test specimens is <10 % (Appendix X4).

7.4 Data Acquisition (6.6 of Test Method C1275)—At a minimum, an autographic record of applied force versus time shall be obtained. If strain is measured by extensometer or strain gage, strain data versus time shall also be recorded. Either analog chart recorders or digital data acquisition systems may be used for this purpose, although a digital record is recommended for ease of data analysis. A digital display or analog chart recorder/plotter should be used in conjunction with the digital data acquisition system to provide an immediate record of the test as a supplement to the digital record. Recording devices shall be accurate to within ± 0.1 % for the entire testing system, including the readout unit as specified in Practices E4 and shall have a minimum data acquisition rate of 10 Hz and a minimum response of 50 Hz.

7.5 Dimension Measuring Devices (6.7 of Test Method C1275)—Micrometers, calipers, and other devices used for measuring linear dimensions shall be accurate and precise to at least one-half the smallest unit to which the individual dimension is required to be measured. For the purposes of this test method, cross-sectional dimensions w and h shall be measured to within ± 1 % or ± 0.02 mm, whichever is greater. Additionally, a micrometer, gage, or optical measurement device capable of determining the hole diameter to within ± 0.05 mm is required.

7.6 Conditioning Chamber—If test materials and test specimens are to be pre-test conditioned in a defined environment (temperature, humidity, and atmosphere), a temperature/vapor/atmosphere-controlled conditioning chamber is required that shall be capable of maintaining the required temperature to within ± 3 °C [± 5 °F] and the required relative vapor level and atmosphere to within ± 5 %. Chamber conditions shall be monitored either on an automated continuous basis or on a manual basis at regular intervals.

7.7 Environmental Test Chamber—The test protocol may specify tensile testing in a controlled atmosphere (humidity, inert, vacuum, or any other gaseous environment) or at moderate test temperatures (<300 °C), or both. If testing is conducted in any environment other than ambient air and temperature, an appropriate environmental test chamber shall

be constructed to provide safe handling, control, and monitoring of the test environment so that constant test environment conditions and temperatures are maintained along the gage section of the test specimen during the tensile test. The test chamber shall control the temperature to within ± 3 °C and the relative humidity at ± 5 % of the set humidity level, respectively. If the load train acts through bellows, fittings, or seals, verify that force losses or errors do not exceed 1 % of the prospective failure forces.

7.8 Elevated Temperature Testing—This test method is used for ambient temperature testing. However, the test method may be used for elevated temperature (>300 °C) testing with the addition/modification of the test apparatus, test specimens, test procedures, and calculations as described in Appendix X2 and referenced in Test Method C1359.

8. Hazards

8.1 During the conduct of this test method, the possibility of flying fragments of broken test material is high. The brittle nature of advanced ceramics and the release of strain energy contribute to the potential release of uncontrolled fragments upon fracture. Means for containment and retention of these fragments for later fractographic reconstruction and analysis is highly recommended. (Plastic shields can be used to encircle the test fixture and specimen and to capture specimen fragments.)

8.2 Exposed fibers at the edges of CMC test specimens present a hazard due to the sharpness and brittleness of the ceramic fiber. All those required to handle these materials shall be well informed of such conditions and the proper handling techniques.

9. Test Specimens and Sampling

9.1 General—Two specific OHT test specimen geometries are defined for general use within the CMC community. These two geometries determine the effect of two typical hole diameters (6 mm and 3 mm) on the strength of a CMC specimen. However, if testing objectives, material limitations, component size requirements, or test data comparability require a different tensile specimen geometry, other tensile specimen geometries with modifications may be used for OHT testing. Annex A1 describes how different Test Method C1275 test specimen geometries may be modified for OHT testing for different testing objectives.

9.2 Baseline Test Specimen Geometry—Two baseline test specimen geometries are defined: Test Specimen A and Test Specimen B. Both test specimens are flat, straight-sided test specimens with a through-hole in the center of the gage section. Nominal thickness shall be 3 mm, with a typical range of 2 mm to 10 mm, inclusive. Test Specimen A uses a 6 mm diameter through-hole in the center of a 36 mm wide gage section. Test Specimen B uses a 3 mm diameter through-hole in the center of a 10 mm wide gage section. The two test specimens are illustrated by the schematic in Fig. 4 and described in Tables 1 and 2. The long axis of the test specimen is oriented to the designated reinforcement axis (for example, 0°, 90°, $\pm 45^\circ$). The grip sections of the test specimen are clamped into the upper and lower grip devices.

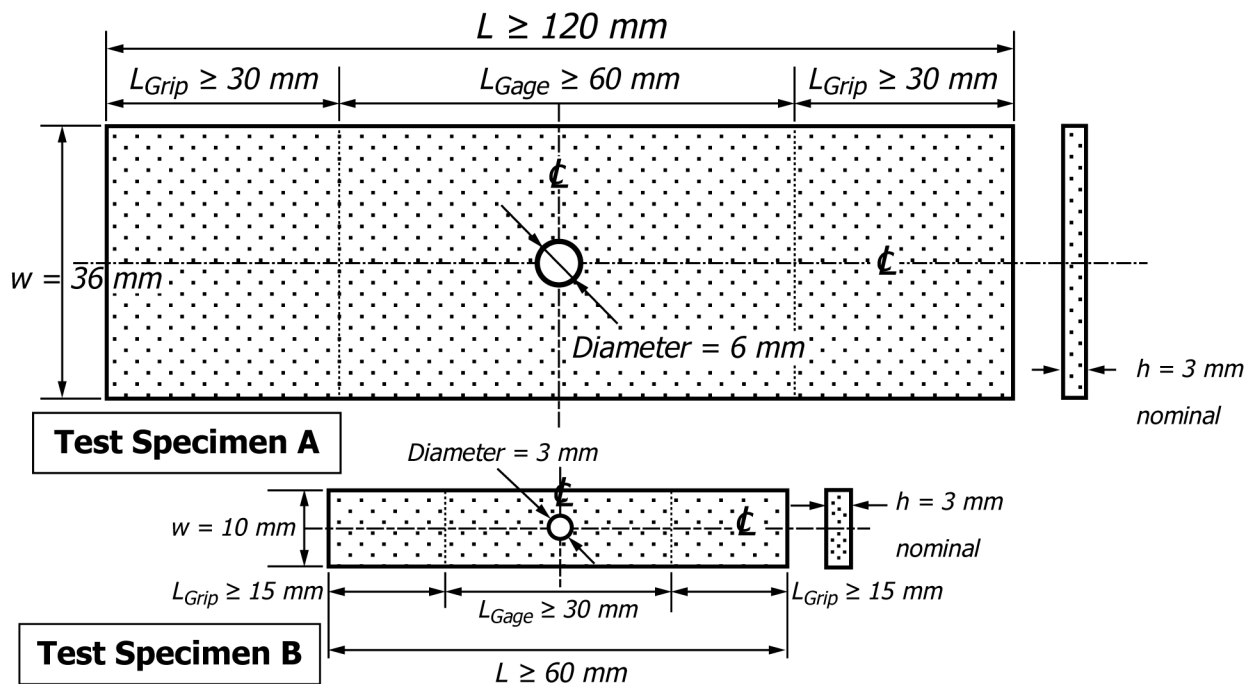

FIG. 4 Open-Hole Tensile Test Specimens A and B

9.2.1 A w/D ratio of 6 for Test Specimen A and a w/D ratio of >3 for Test Specimen B are typically sufficient to minimize stress-strain interactions between the center hole and the specimen edges. Test specimens with lower and higher w/D ratios can be tested to determine the interactions between the edge and hole stress-strain fields as a function of specimen width and hole diameter. (See Appendix X1.)

9.2.2 The gage section shall be long enough to provide a significant amount of material under stress and to produce a uniform strain field in the specimen outside of the influence of the center hole. Typically, the gage section length (L_{gage}) is greater than ten times the hole diameter (D)—($L_{gage} / D > 10$).

9.2.3 The specimen length shall be long enough to minimize bending stresses caused by minor grip eccentricities. The grip sections shall be long enough for adequate grip surface that will prevent slippage in the grips or crushing in the grip sections. Typically, each grip length section is $\sim 50\%$ of the gage length for a grip length of 30 mm and 15 mm for the two test specimen geometries. Different ceramic composite materials with different fiber architectures, porosities, and tensile and shear strengths may require longer gage, grip, and specimen lengths to promote failure through the center hole and to prevent invalid, out-of-gage failures.

9.2.4 *Reinforcement Architecture*—The CMC test specimens typically have multidirectional fiber orientations (fibers are oriented in a minimum of two directions producing a 2- or 3-dimensional reinforcement structure) and a balanced, symmetric, and laminated reinforcement architecture.

9.2.5 Test specimens with 1-D uniaxial reinforcement, 3-D woven or braided reinforcement, unbalanced, nonsymmetrical architectures, or combinations thereof, may be tested with appropriate consideration of how those different architectures

will affect the open-hole tensile strength. Any significant variation in the reinforcement architecture of the test material shall be clearly noted and described in the test report.

9.2.6 Any variation in specimen hole diameter or position or gage section width or length, or combinations thereof, from that specified for Test Specimens A and B, shall be clearly noted in the report.

9.3 *Specimen Fabrication and Marking*—Test specimens shall be cut to align the long axis of the test specimen with the desired test reinforcement axis (for example, the 0° , 90° , or $\pm 45^\circ$ direction with reference to the principal structural axis).

9.3.1 *Specimen Machining*—Paragraph 8.2 of Test Method C1275 specifies four different ceramic composite machining protocols: as-fabricated, application-matched machining, customary practices, and standard procedures. Depending upon the intended application of the tensile strength data, use one of the defined Test Method C1275 machining procedures. The machining procedure must avoid notches, undercuts, rough or uneven surfaces, edge damage, or delaminations and produce machined surfaces that are flat and parallel within the specified tolerances. Record and report the machining procedure in sufficient detail to allow replication. Regardless of the preparation procedure used, sufficient details regarding the procedure must be reported to allow replication.

9.3.2 The surface condition on the flat faces of the test specimen can take two forms: an as-fabricated condition and machined condition. For the as-fabricated condition, only the length and the width are machined to the specified size for a regular machined edge. The two flat faces of the test specimen are not machined and may have surfaces with marked irregularities and variable surface finish. For the face-machined condition, the faces of the test specimen are machined by a

defined method to produce the desired surface finish. Tolerances on the thickness dimension apply only to machined surface faces.

9.3.3 Hole Preparation—Special care shall be taken to ensure that creation of the specimen hole does not delaminate or otherwise damage the material surrounding the hole. Holes should be drilled undersized and carefully reamed to final dimensions. Record and report the specimen hole preparation methods.

9.3.4 Hole walls may be backfilled, sealed, or coated to match the specimen surface condition and permeability. Any post-machining hole treatments shall be noted in the report.

9.3.5 Label/mark the individual test specimens so that they will be distinct from each other and traceable back to the starting material. The label/mark system shall have no effect or influence on the gage section, and the test procedure should not affect the labels/markings.

9.4 Specimen Gripping and Use of End Tabs—In many tensile tests of unnotched fiber-reinforced composites, end tabs are used in the grip section of flat, straight-sided test specimens to prevent invalid failure in the grip section. However, end tabs may not be needed in the OHT test, if the open center hole acts as a sufficient stress riser to force failure at the center hole. If OHT screening tests for a specific composite material and specimen geometry show invalid failure away from the center hole (at or close to the grip section), end tabs should be used to produce valid tests (fracture through the center hole). See 8.1.3 of Test Method **C1275** and 8.2.2.2 of Test Method **D3039/D3039M** for guidance on the design, fabrication, attachment, and use of polymer composite or metal end tabs for composite tensile testing. If used, prepare, attach, and bond the end tabs to the specimens per the test plan. This should be done before testing, so that the bond adhesive has time to cure to full strength.

9.5 Unnotched Test Specimens—For direct comparison purposes, tensile tests may be done on unnotched (no-hole) tensile test specimens of the same composite material (composition, reinforcement architecture, density, porosity, etc.) and equal gage section dimensions (thickness, width, and length) with the same test conditions and experimental parameters. If flat, straight-sided test specimens are tested for unnotched tensile strength, end tabs (**9.4**) are typically needed to produce valid fracture in the gage section. Tensile specimens with contoured gage sections may be used for unnotched strength, if the gage section has dimensions (width, thickness, and length) equal to the OHT specimen. (See Annex A2 of Test Method **C1275** for contoured gage section specimens.)

9.6 Surface Measurement—In some cases it is desirable, but not required, to measure surface roughness in the gage section to quantify the specimen surface condition. Profilometry (contact and non-contact) can be used to determine surface roughness parallel and perpendicular to the tensile axis across a sufficient area to adequately characterize the surface. When measured, surface roughness shall be reported.

9.7 Nondestructive evaluation (ultrasonics, thermal imaging, computerized tomography, etc.) may be used to assess internal morphology, discontinuities, and features

(delaminations, porosity concentrations, etc.) in the composite test specimens. Describe the method and the observations/measurements/results of any nondestructive evaluations and include them in the final report.

9.8 If strain gages are used for strain measurement, position, align, and bond the selected strain gages to the test specimen(s) prior to testing. Record and report the type, count, configuration, position, and bonding method of the strain gages.

9.9 Test Specimen Handling and Storage—Care shall be exercised in the handling, packaging, and storage of finished test specimens to avoid the introduction of surface flaws. In addition, attention shall be given to pre-test storage of test specimens in controlled environments or desiccators to avoid environmental (for example, humidity) degradation of test specimens prior to testing.

9.10 Test Count and Sampling—A minimum of five (5) valid test specimens is required for the purpose of estimating a mean/average with minimum precision. A greater number of valid test specimens may be necessary, if estimates regarding the form of the strength distribution are required. The procedures outlined in Practice **E122** may be used to estimate the number of tests needed for determining a mean with a specified precision. For Weibull statistical analysis, Practice **C1239** shall be used to determine the number of tests required for Weibull strength distribution analysis. If material cost or test specimen availability limits the number of possible tests, fewer tests can be conducted to determine an indication of material properties.

9.10.1 Test specimens shall be selected and prepared from representative ceramic composite samples that meet the stated testing objectives and requirements. Practice **E105** and Guide **E1402** provide guidance and direction on developing a sampling plan. The method of sampling shall be reported.

9.11 Valid Test—A valid individual test is one which meets all the following requirements: all the testing requirements of this test method are met; failure/rupture occurs at the test center hole; and, if measured, the percent bending for a test specimen is less than 10 % (see **7.3** and **Appendix X4**).

10. Calibration

10.1 Calibration shall be in accordance with Test Methods **C1275** and **E251** and Practices **E4** and **E83**.

11. Conditioning

11.1 Test objectives may call for pre-test conditioning of the test specimens in a conditioning chamber with defined atmosphere, humidity, temperature, and time conditions. The pre-test specimen conditioning process (to include specified environmental exposure temperatures, conditions, and times) shall be reported with the test data.

11.2 If no explicit conditioning process is performed, the specimen conditioning status shall be reported as “unconditioned.”

12. Procedure

12.1 Test Plan Parameters to Be Specified Prior to Test:

12.1.1 The test specimen geometry, dimensions, tolerances, and test axis orientation; specimen sampling method; specimen preparation method (to include hole preparation); and specimen storage requirements (for notched and unnotched test specimens).

12.1.2 The required tensile properties and the desired data reporting format.

12.1.3 Determine the required material properties, accuracy, and data reporting requirements prior to test for proper selection of instrumentation and data recording equipment. Estimate the specimen strength to aid in transducer selection, calibration of equipment, and determination of equipment settings.

12.1.4 If required, the pre-test conditioning test parameters.

12.1.5 If required, test methods and parameters for specific gravity, bulk density, and apparent porosity.

12.1.6 If used, extensometer and strain gage requirements and related calculations.

12.1.7 *Test Modes and Rates*—Test modes and rates may have distinct and strong influences on fracture behavior of advanced ceramics, even at ambient temperatures, depending on test environment or condition of the test specimen. Recommended rates of testing are intended to be sufficiently rapid to obtain the maximum possible tensile strength at fracture of the material. In ambient temperature testing, the displacement/strain rate is typically set to produce specimen failure/rupture in 5 s to 10 s (per Test Method C1275) to minimize environmental effects when testing in ambient air. However, rates other than those recommended here may be used to evaluate rate effects (see 9.2 of Test Method C1275). In all cases, the test mode and rate must be reported.

12.1.7.1 For ceramic composites, displacement control is preferred for the test mode to prevent “runaway” failure. The shift to nonlinear stress-strain behavior of the “graceful” fracture process of CMCs indicates a cumulative damage process that is strain dependent. Generally, displacement-controlled tests are employed in such cumulative damage and deformation processes to prevent a “runaway” condition (that is, rapid, uncontrolled deformation and fracture) characteristic of force- or stress-controlled tests.

12.1.8 If required, the environmental test conditions for temperature, humidity, and atmosphere and the requirements for the environmental test chamber.

12.1.9 If required, the elevated temperature test conditions (temperature and atmosphere) and the requirements for the heating system, furnace, and temperature control. (See Appendix X2.)

12.2 *Specimen Preparation and Measurement:*

12.2.1 Cut, machine, drill, and finish the test specimens per the specimen preparation section of the test plan.

12.2.2 Condition the specimens as specified in the test plan. Store all (unconditioned and conditioned) specimens in the defined storage conditions until testing.

12.2.3 If grip tabs are used, prepare and attach the grip tabs to the test specimens as per the test plan. Allow enough time for the adhesive to cure to full strength.

12.2.4 *Specimen Measurement*—Following any pre-test conditioning, but prior to tensile testing, measure and report the following dimensions of each individual test specimen.

12.2.5 Measure and record the gage section width (w) to within 0.5 mm (Test Specimen A) or 0.2 mm (Test Specimen B) at a minimum of three points along the gage section length: at the center hole width, and 10 mm left and right of the center hole width (see Fig. 5). Measure and record the gage section thickness (h) to within $\pm 2\%$, at a minimum of eight points in the gage section (see Fig. 5). To avoid damage in the critical gage section area, it is recommended that these measurements be made with a self-limiting (friction or ratchet mechanism), flat, anvil-type micrometer per Test Method C1275.

12.2.6 For test specimens with the center hole, measure and record the hole diameter (D) to an accuracy of ± 0.1 mm at two diameters 90° apart. Optical measurement of the diameter is preferred, to prevent damage to the hole surface from calipers or gages. With mechanical measurement devices, use special care to avoid surface damage. Inspect the hole and areas adjacent to the hole for edge damage, delaminations, or both. Report the location and size of any edge damage or delaminations found.

12.2.7 Measure the gage section length to an accuracy of ± 1 mm.

12.2.8 Bulk density can be calculated from mass and dimensional measurements. Specific gravity and apparent porosity may be evaluated by Test Method C373 (Archimedes

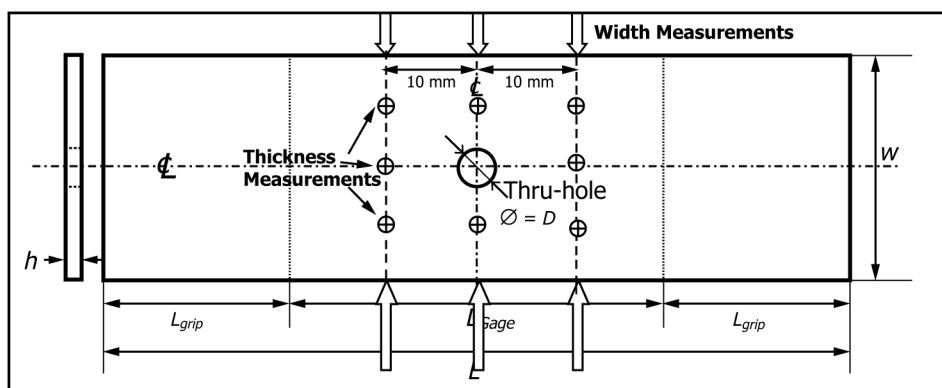

FIG. 5 Gage Section Measurement Locations

immersion). If specific gravity and porosity fraction are measured on witness samples, then obtain these samples from the same panels being tested.

12.3 Test System Setup and Specimen Insertion:

12.3.1 Install and check the test machine, the force control system, the force transducers, the loading fixtures, the strain measurement system, and the data recording system per Test Method **C1275**.

12.3.2 It is recommended to check and verify the alignment in the load train at the beginning and end of the test series, per 6.5 of Test Method **C1275**.

12.3.3 If used, install and check the environmental test chamber or the heating/furnace system.

12.3.4 Mount the test specimen in the grips and ensure proper alignment so that the specimen long axis is aligned with the loading axis of the test machine. Take care not to induce flexural or torsional forces and strain on the test specimen. Mark the test specimen with an indelible marker as to the top section and the front (side facing the operator) in relation to the test machine.

12.3.5 Prepare the data acquisition systems for data logging. Record force versus time continuously, or at frequent regular intervals; for this test method, a minimum sampling rate of 10 Hz and a minimum of 100 data points per test are recommended.

12.3.6 If strain response in the gage section is measured and recorded, attach and connect the strain measurement equipment (extensometer(s) or strain gages) per **Appendix X3**.

12.3.7 Determine the ambient temperature and relative humidity in accordance with Test Method **E337**.

12.3.8 Set the selected test mode and test rate on the test machine. Zero the force transducer. Preload the test specimen to remove the “slack” from the load train. The amount of preload will depend on the material and tensile test specimen geometry, and therefore must be determined for each test situation.

12.3.9 If testing is done in the environmental test chamber, condition the test specimen at the defined temperature and humidity for the designated period of time. Record the environmental conditions and the “time to equilibrium” for each test.

12.3.10 If testing is done at elevated temperatures, see **Appendix X2**.

12.4 Conducting the Tensile Test:

12.4.1 Initiate the data acquisition for force, time, displacement, and strain (if measured). Initiate the test mode. If any early damage/failure or changes in stress-strain response

are noted, note the force, displacement, and mode of damage at such points. Record the method used to determine the initial failure (force or slope change, visual, acoustic emission, etc.). Record the maximum force, the breaking force (if different from the maximum force), and the crosshead displacement at, or as near as possible to, the moment of rupture. The maximum/breaking force shall be measured to within $\pm 1.0\%$ of the force range.

12.4.2 After test specimen fracture, disable the action of the test machine and the data acquisition system. Carefully remove the test specimen sections from the grips. Take care not to damage the fracture surfaces by preventing them from contacting with each other or other objects. Place the test specimen sections along with other fragments from the gage section in a suitable nonmetallic container for later analysis.

12.4.3 Repeat the test for each OHT test specimen and for each unnotched tensile test specimen.

12.5 *Failure Modes*—Failures that do not occur at and through the center hole are not valid or acceptable. Test new specimens for each invalid test to obtain the desired number of valid test data.

12.5.1 Test Methods **D5766/D5766M** and **D3039/D3039M** provide a failure mode description system with three factors for failure type, failure area, and failure location (see **Table 3**). The failure mode description system may be used in the testing report. Failure mode codes for valid OHT tests are limited to *GM, where the second and third place holders are limited to “Gage Middle.” The first place holder would normally be either L for Lateral, A for Angled, or M for Multi-mode. **Fig. 6** illustrates these three acceptable failure modes. The mode of failure may be found to vary on different sides of the hole. Both invalid OHT tests and unnotched tests may also be described with the failure mode description system.

12.5.2 *Fractography*—Fractographic examination of each failed test specimen is recommended to characterize the fracture behavior of CMCs. Visual examination and light microscopy should be conducted to determine the mode and type of fracture (that is, brittle or fibrous). In addition, although quantitatively beyond the scope of this test method, subjective observations can be made of the length of fiber pullout, orientation of fracture plane, degree of interlaminar fracture, and other pertinent details of the fracture surface. The method and results of fractographic analysis shall be reported. It shall be clearly noted on the test report if a fractographic analysis is not performed.

TABLE 3 Three-Factor Failure Mode Description System for OHT Testing (from Test Methods **D5766/D5766M and **D3039/D3039M**)**

Failure Mode	First Factor		Second Factor		Third Factor	
	Code	Failure Area	Code	Failure Location	Code	
Angle	A	Inside grip	I	Bottom		B
Edge delam.	D	At grip	A	Top		T
Grip/Tab	G	<1 W from grip	W	Left		L
Lateral	L	Gage hole	G	Right		R
Multi-mode	M	Multiple areas	M	Middle (at center hole)		M
Longit. split	S	Unknown	U	Unknown		U
Explosive	X					
Other	O					