



Designation: **E2472–12 (Reapproved 2018)<sup>ε2</sup>** E2472 – 12 (Reapproved 2018)<sup>ε2</sup>

## Standard Test Method for Determination of Resistance to Stable Crack Extension under Low-Constraint Conditions<sup>1</sup>

This standard is issued under the fixed designation E2472; the number immediately following the designation indicates the year of original adoption or, in the case of revision, the year of last revision. A number in parentheses indicates the year of last reapproval. A superscript epsilon ( $\epsilon$ ) indicates an editorial change since the last revision or reapproval.

<sup>ε1</sup> NOTE—Sections 7.4.1, 7.4.2, 9.3.1.4, A1.1.3, A2.1.3, and Fig. 7 were editorially corrected in May 2020.

<sup>ε2</sup> NOTE—Section A2.1.3 was editorially corrected in June 2023.

### 1. Scope

1.1 This standard covers the determination of the resistance to stable crack extension in metallic materials in terms of the critical crack-tip-opening angle (CTOA),  $\psi_c$  and/or the crack-opening displacement (COD),  $\delta_5$  resistance curve (**1**).<sup>2</sup> This method applies specifically to fatigue pre-cracked specimens that exhibit low constraint (crack-size-to-thickness and un-cracked ligament-to-thickness ratios greater than or equal to 4) and that are tested under slowly increasing remote applied displacement. The test specimens are the compact, C(T), and middle-crack-tension, M(T), specimens. The fracture resistance determined in accordance with this standard is measured as  $\psi_c$  (critical CTOA value) and/or  $\delta_5$  (critical COD resistance curve) as a function of crack extension. Both fracture resistance parameters are characterized using either a single-specimen or multiple-specimen procedures. These fracture quantities are determined under the opening mode (Mode I) of loading. Influences of environment and rapid loading rates are not covered in this standard, but the user must be aware of the effects that the loading rate and laboratory environment may have on the fracture behavior of the material.

1.2 Materials that are evaluated by this standard are not limited by strength, thickness, or toughness, if the crack-size-to-thickness ( $a/B$ ) ratio and the ligament-to-thickness ( $b/B$ ) ratio are greater than or equal to 4, which ensures relatively low and similar global crack-front constraint for both the C(T) and M(T) specimens (**2, 3**).

1.3 The values stated in SI units are to be regarded as standard. No other units of measurement are included in this standard.

1.4 *This standard does not purport to address all of the safety concerns, if any, associated with its use. It is the responsibility of the user of this standard to establish appropriate safety, health, and environmental practices and determine the applicability of regulatory limitations prior to use.*

1.5 *This international standard was developed in accordance with internationally recognized principles on standardization established in the Decision on Principles for the Development of International Standards, Guides and Recommendations issued by the World Trade Organization Technical Barriers to Trade (TBT) Committee.*

### 2. Referenced Documents

#### 2.1 ASTM Standards:<sup>3</sup>

<sup>1</sup> This test method is under the jurisdiction of ASTM Committee E08 on Fatigue and Fracture and is the direct responsibility of Subcommittee E08.07 on Fracture Mechanics.

Current edition approved Nov. 1, 2018. Published December 2018. Originally approved in 2006. Last previous edition approved in 2012 as E2472–12<sup>ε1</sup>. DOI: 10.1520/E2472-12R18E01-10.1520/E2472-12R18E02.

<sup>2</sup> The boldface numbers in parentheses refer to the list of references at the end of this standard.

<sup>3</sup> For referenced ASTM standards, visit the ASTM website, www.astm.org, or contact ASTM Customer Service at service@astm.org. For *Annual Book of ASTM Standards* volume information, refer to the standard's Document Summary page on the ASTM website.

[E4 Practices for Force Calibration and Verification of Testing Machines](#)  
[E8/E8M Test Methods for Tension Testing of Metallic Materials](#)  
[E399 Test Method for Linear-Elastic Plane-Strain Fracture Toughness of Metallic Materials](#)  
[E561 Test Method for  \$K\_R\$  Curve Determination](#)  
[E647 Test Method for Measurement of Fatigue Crack Growth Rates](#)  
[E1290 Test Method for Crack-Tip Opening Displacement \(CTOD\) Fracture Toughness Measurement \(Withdrawn 2013\)<sup>4</sup>](#)  
[E1820 Test Method for Measurement of Fracture Toughness](#)  
[E1823 Terminology Relating to Fatigue and Fracture Testing](#)  
[E2309 Practices for Verification of Displacement Measuring Systems and Devices Used in Material Testing Machines](#)

2.2 *ISO Standards:*<sup>5</sup>

[ISO 22889:2007 Metallic Materials—Method of Test for the Determination of Resistance to Stable Crack Extension Using Specimens of Low Constraint](#)  
[ISO 12135 Metallic Materials—Unified Method of Test for the Determination of Quasistatic Fracture Toughness](#)

### 3. Terminology

3.1 Terminology [E1823](#) is applicable to this test standard.

3.2 *Definitions:*

3.2.1 *crack extension,  $\Delta a$  [L],  $n$* —an increase in crack size.

3.2.1.1 *Discussion—*

It should be noted that in thin-sheet and thick-plate materials under low constraint conditions, the crack extension observed on the surface of the specimen may be significantly less than that in the interior of the specimen due to the effects of crack tunneling. This must be considered if direct optical techniques are used to monitor and measure free-surface crack extension. Indirect crack extension measurement techniques such as unloading compliance and electric-potential drop method may be used in place of (or to complement) the direct optical techniques to provide a measure of average crack extension. (See Test Method [E647](#) for compliance methods for C(T) and M(T) specimens; and ISO 12135 and Test Method [E647](#) for electric potential-drop methods for C(T) specimens.)

3.2.2 *crack size,  $a$  [L],  $n$* —principal linear dimension used in the calculation of fracture mechanics parameters for through thickness cracks.

3.2.2.1 *Discussion—*

A measure of the crack size after the fatigue pre-cracking stage is denoted as the original crack size,  $a_o$ . The value for  $a_o$  may be obtained using surface measurement, unloading compliance, electric-potential drop or other methods where validation procedures for the measurements are available.

3.2.3 *crack-tip-opening angle (CTOA),  $\psi$  [deg],  $n$* —relative angle of crack surfaces resulting from the total deformation (elastic plus plastic) measured (or calculated) at 1-mm behind the current crack tip as the crack stably tears, where  $\psi = 2 \tan^{-1} (\delta_1/2)$ .

3.2.4 *critical crack-tip-opening angle (CTOA<sub>c</sub>),  $\psi_c$  [deg],  $n$* —steady-state relative angle of crack surfaces resulting from the total deformation (elastic plus plastic) measured (or calculated) at 1-mm behind the current crack tip as the crack stably tears, where  $\psi_c = 2 \tan^{-1} (\delta_{1c}/2)$ .

3.2.4.1 *Discussion—*

Critical CTOA value tends to approach a constant, steady-state value after a small amount of crack extension (associated with crack tunneling and transition from flat-to-slant crack extension).

3.2.5 *crack-opening displacement, (COD)  $\delta_5$  [L]*—force-induced separation vector between two points. The direction of the vector is normal to the crack plane (normal to the facing surfaces of a crack) at a specified gage length. In this standard,  $\delta_5$  is measured at the fatigue precrack tip location over a gage length of 5-mm as the crack stably tears.

3.2.6 *crack-tip-opening displacement (CTOD),  $\delta_1$  [L],  $n$* —relative displacement of crack surfaces resulting from the total deformation (elastic plus plastic) measured (or calculated) at 1- mm behind the current crack tip as the crack stably tears.

<sup>4</sup> The last approved version of this historical standard is referenced on [www.astm.org](http://www.astm.org).

<sup>5</sup> Available from International Organization for Standardization (ISO), 1, ch. de la Voie-Creuse, Case postale 56, CH-1211, Geneva 20, Switzerland, <http://www.iso.ch>.

3.2.7 *critical crack-tip-opening displacement (CTOD<sub>c</sub>)*,  $\delta_{1c}$  [L], *n*—steady-state relative displacement of crack surfaces resulting from the total deformation (elastic plus plastic) measured (or calculated) at 1-mm behind the current crack tip as the crack stably tears.

3.2.8 *crack extension resistance curve (R curve)*, *n*—variation of  $\delta_5$  with crack extension,  $\Delta a$ .

3.2.9 *effective yield strength*,  $\sigma_y[FL^{-2}]$ , *n*—an assumed value of uniaxial yield strength that represents the influence of plastic yielding upon fracture test parameters.

3.2.9.1 *Discussion*—

Effective yield strength is calculated as the average of the 0.2 % offset yield strength  $\sigma_{YS}$ , and the ultimate tensile strength,  $\sigma_{TS}$  as follows:

$$\sigma_y = (\sigma_{YS} + \sigma_{TS})/2 \quad (1)$$

NOTE 1—The yield and ultimate tensile strength are determined from Test Methods E8/E8M.

3.2.9.2 *Discussion*—

In estimating  $\sigma_y$ , influences of testing conditions, such as loading rate and temperature, should be considered.

3.2.10 *final crack size*,  $a_f$  [L], *n*—crack extension at end of stable tearing ( $a_f = a_o + \Delta a_f$ ).

3.2.11 *final remaining ligament*,  $b_f$  [L], *n*—distance from the tip of the final crack size to the back edge of the specimen, that is  $b_f = W - a_f$ .

3.2.12 *force*,  $P$  [F], *n*—force applied to a test specimen or to a component.

3.2.13 *minimum crack extension*,  $\Delta a_{min}$  [L], *n*—crack extension beyond which  $\psi_c$  is nearly constant.

3.2.14 *maximum crack extension*,  $\Delta a_{max}$  [L], *n*—crack extension limit for  $\psi_c$  and  $\delta_5$  controlled crack extension.

3.2.15 *maximum fatigue force*,  $P_f$  [F], *n*—maximum fatigue force applied to specimen during pre-cracking stage.

3.2.16 *modulus of elasticity*,  $E$  [FL<sup>-2</sup>], *n*—the ratio of stress to corresponding strain below the proportional limit.

3.2.17 *notch size*,  $a_n$  [L], *n*—distance from a reference plane to the front of the machined notch, such as the force line in the compact specimen to the notch front or from the center line in the middle-crack-tension specimen to the notch front.

3.2.18 *original crack size*,  $a_o$  [L], *n*—the physical crack size at the start of testing.

3.2.19 *original ligament*,  $b_o$  [L], *n*—distance from the original crack front to the back edge of the specimen, that is  $b_o = W - a_o$ .

3.2.20 *remaining ligament*,  $b$  [L], *n*—distance from the physical crack front to the back edge of the specimen, that is  $b = W - a$ .

3.2.21 *specimen thickness*,  $B$  [L], *n*—distance between the parallel sides of a test specimen or component. Side grooving is not allowed.

3.2.22 *specimen width*,  $W$  [L], *n*—distance from a reference position (for example, the force line of a compact specimen or center line in the middle-crack-tension specimen) to the rear surface of the specimen. (Note that the total width of the M(T) specimen is defined as  $2W$ .)

#### 4. Summary of Test Method

4.1 The objective of this standard is to induce stable crack extension in a fatigue pre-cracked, low-constraint test specimen while monitoring and measuring the COD at the original fatigue pre-crack-tip location (4, 5) or the CTOA (or CTOD) at 1-mm behind the stably tearing crack tip (6, 7), or both. The resistance curve associated with the  $\delta_5$  measurements and the critical limiting value

of the CTOA measurements are used to characterize the corresponding resistance to stable crack extension. In contrast, the CTOD values determined from Test Method E1290 (high-constraint bend specimens) are values at one or more crack extension events, such as the CTOD at the onset of brittle crack extension with no significant stable crack extension.

4.2 Either of the fatigue pre-cracked, low-constraint test specimen configurations specified in this standard [C(T) or M(T)] may be used to measure or calculate either of the fracture resistance parameters considered. The fracture resistance parameters, CTOA (or CTOD) and  $\delta_5$ , may be characterized using either a single-specimen or multiple-specimen procedure. In all cases, tests are performed by applying slowly increasing displacements to the test specimen and measuring the forces, displacements, crack extension and angles realized during the test. The forces, displacements and angles are then used in conjunction with certain pre-test and post-test specimen measurements to determine the material's resistance to stable crack extension.

4.3 Four procedures for measuring crack extension are: surface visual, unloading compliance, electrical potential, and multiple specimens.

4.4 Two techniques are presented for measuring CTOA: optical microscopy (OM) (8) and digital image correlation (DIC) (9).

4.5 Three techniques are presented for measuring COD:  $\delta_5$  clip gage (5), optical microscopy (OM) (8), and digital image correlation (DIC) (9).

4.6 Data generated following the procedures and guidelines contained in this standard are labeled qualified data and are insensitive to in-plane dimensions and specimen type (tension or bending forces), but are dependent upon sheet or plate thickness.

## 5. Significance and Use

5.1 This test method characterizes a metallic material's resistance to stable crack extension in terms of crack-tip-opening angle (CTOA),  $\psi$  and/or crack-opening displacement (COD),  $\delta_5$  under the laboratory or application environment of interest. This method applies specifically to fatigue pre-cracked specimens that exhibit low constraint and that are tested under slowly increasing displacement.

5.2 When conducting fracture tests, the user must consider the influence that the loading rate and laboratory environment may have on the fracture parameters. The user should perform a literature review to determine if loading rate effects have been observed previously in the material at the specific temperature and environment being tested. The user should document specific information pertaining to their material, loading rates, temperature, and environment (relative humidity) for each test.

5.3 The results of this characterization include the determination of a critical, lower-limiting value, of CTOA ( $\psi_c$ ) or a resistance curve of  $\delta_5$ , a measure of crack-opening displacement against crack extension, or both.

5.4 The test specimens are the compact, C(T), and middle-crack-tension, M(T), specimens.

5.5 Materials that can be evaluated by this standard are not limited by strength, thickness, or toughness, if the crack-size-to-thickness ( $a/B$ ) ratio or ligament-to-thickness ( $b/B$ ) ratio are equal to or greater than 4, which ensures relatively low and similar global crack-front constraint for both the C(T) and M(T) specimens (2, 3).

5.6 The values of CTOA and COD ( $\delta_5$ ) determined by this test method may serve the following purposes:

5.6.1 In research and development, CTOA ( $\psi_c$ ) or COD ( $\delta_5$ ), or both, testing can show the effects of certain parameters on the resistance to stable crack extension of metallic materials significant to service performance. These parameters include, but are not limited to, material thickness, material composition, thermo-mechanical processing, welding, and thermal stress relief.

5.6.2 For specifications of acceptance and manufacturing quality control of base materials.

5.6.3 For inspection and flaw assessment criteria, when used in conjunction with fracture mechanics analyses. Awareness of differences that may exist between laboratory test and field conditions is required to make proper flaw assessment.

5.6.4 The critical CTOA ( $\psi_c$ ) has been used with the elastic-plastic finite-element method to accurately predict structural response and force carrying capacity of simple and complex cracked structural components, see [Appendix X1](#).

5.6.5 The  $\delta_5$  parameter has been related to the J-integral by means of the Engineering Treatment Model (ETM) **(10)** and provides an engineering approach to predict the structural response and force carrying capacity of cracked structural components.

5.6.6 The K-R curve method (Practice **E561**) is similar to the  $\delta_5$ -resistance curve, in that, the concept has been applied to both C(T) and M(T) specimens (under low-constraint conditions) and the K-R curve concept has been used successfully in industry **(11)**. However, the  $\delta_5$  parameter has been related to the J-integral and the parameter incorporates the material non-linear effects in its measurement. Comparisons have also been made among various fracture criteria on fracture of C(T), M(T) and a structurally configured crack configuration **(12)** that were made of several different materials (two aluminum alloys and a very ductile steel), and the K-R curve concept was found to have limited application, in comparison to the critical CTOA<sub>c</sub> ( $\psi_c$ ) concept.

## 6. Apparatus

6.1 This procedure involves measurement of applied force,  $P$ , crack extension,  $\Delta a$ , and crack-opening displacement at the original fatigue crack tip location or crack-tip-opening angle at the current crack tip, or both. Testing is performed under crosshead displacement control in a tension-testing machine that conforms to the requirements of Practice **E4**.

6.1.1 *Calibration*—Calibration of all measuring apparatus shall be traceable either directly or indirectly via a hierarchical chain to an accredited calibration laboratory.

6.1.2 *Force Application*—The combined force sensing and recording devices shall conform to ASTM standards, such as Practices **E4** and **E2309**. The test machine shall operate at a constant displacement rate. A force measuring system of nominal capacity exceeding  $1.2P_L$  shall be used, where:

$$P_L = B (W - a_o)^2 \sigma_{TS} / (2W + a_o) \quad \text{for compact specimen} \quad (2)$$

$$P_L = 2B (W - a_o) \sigma_{TS} \quad \text{for middle - crack - tension specimen} \quad (3)$$

6.2 *Fixturing for the Compact [C(T)] Specimens*—Compact specimens shall be loaded using a clevis and pin arrangement designed to minimize friction. The arrangement shall ensure load train alignment as the specimen is loaded in tension. A loading clevis suitable for testing C(T) specimens is shown in [Fig. 1](#). Each half of the specimen is held by such a clevis and loaded through pins, in order to allow rotation of the specimen during testing. To provide rolling contact between the loading pins and the clevis holes, these holes are produced with small flats on the loading surfaces. Other clevis designs may be used if it can be demonstrated that they will accomplish the same result as the design shown. Round-bottomed holes shall not be allowed for single specimen (unloading compliance) tests because pin movement may be restricted. Clevises and pins should be fabricated from steels of sufficient strength and hardness (greater than 40 HRC (400 HV)) to elastically resist indentation forces. The critical tolerances and suggested proportions of the clevis and pins are given in [Fig. 1](#). The pin diameter is  $0.24W (+0.000W/-0.005W)$ . The particular configuration and dimensions in the gripping area should be selected by the user to match the test machine fixtures and capabilities. These proportions are based on specimens having  $W/B = 8$ . If a 1900-MPa yield strength maraging or stainless steel is used for the clevis and pins, adequate strength will be obtained. If a lower strength grip material is used, or if substantially larger specimens are required at a given  $\sigma_{YS}/E$  ratio, then heavier grips may be required. Attention should be given to achieving good alignment through careful machining of all auxiliary gripping fixtures. All specimens shall be tested with anti-buckling guide plates, as shown in [Fig. 2](#). The anti-buckling guide plates must cover a large portion of the specimen. Placing thin sheets of a low friction material, such as TFE-fluorocarbon, between the anti-buckling plates and the specimen surface, and only hand-tightening the perimeter bolts has been shown to provide adequate stability while minimizing friction. As shown in [Fig. 2](#), openings must be machined into the anti-buckling plates in the appropriate locations to allow for the monitoring and measuring of crack extension and the crack-tip-opening angles and  $\delta_5$ . Measurement of crack-mouth-opening displacements using a clip gage may be made to determine crack size using the unloading compliance method.

6.3 *Fixturing for the Middle-Crack-Tension [M(T)] Specimens*—Middle-crack-tension specimens shall be loaded using hydraulically-clamped or bolted grips designed to carry the applied force in friction. Bolt bearing should be avoided to minimize non-uniform loading. The arrangement shall ensure alignment of the specimen to minimize in-plane and out-of-plane bending. All specimens shall be tested with anti-buckling guide plates, as shown in [Fig. 3](#). The anti-buckling guide plates must cover a large portion of the specimen. Support only along the crack plane has been shown to be insufficient to prevent buckling between the grip lines and the crack plane for thin-sheet materials. Flat plates, as shown in [Fig. 3\(a\)](#), are sufficient for small M(T) specimens ( $2W < 600$  mm), but flat plates stiffened with I-beams, as illustrated in [Fig. 3\(b\)](#), have been shown to be required for M(T) specimens

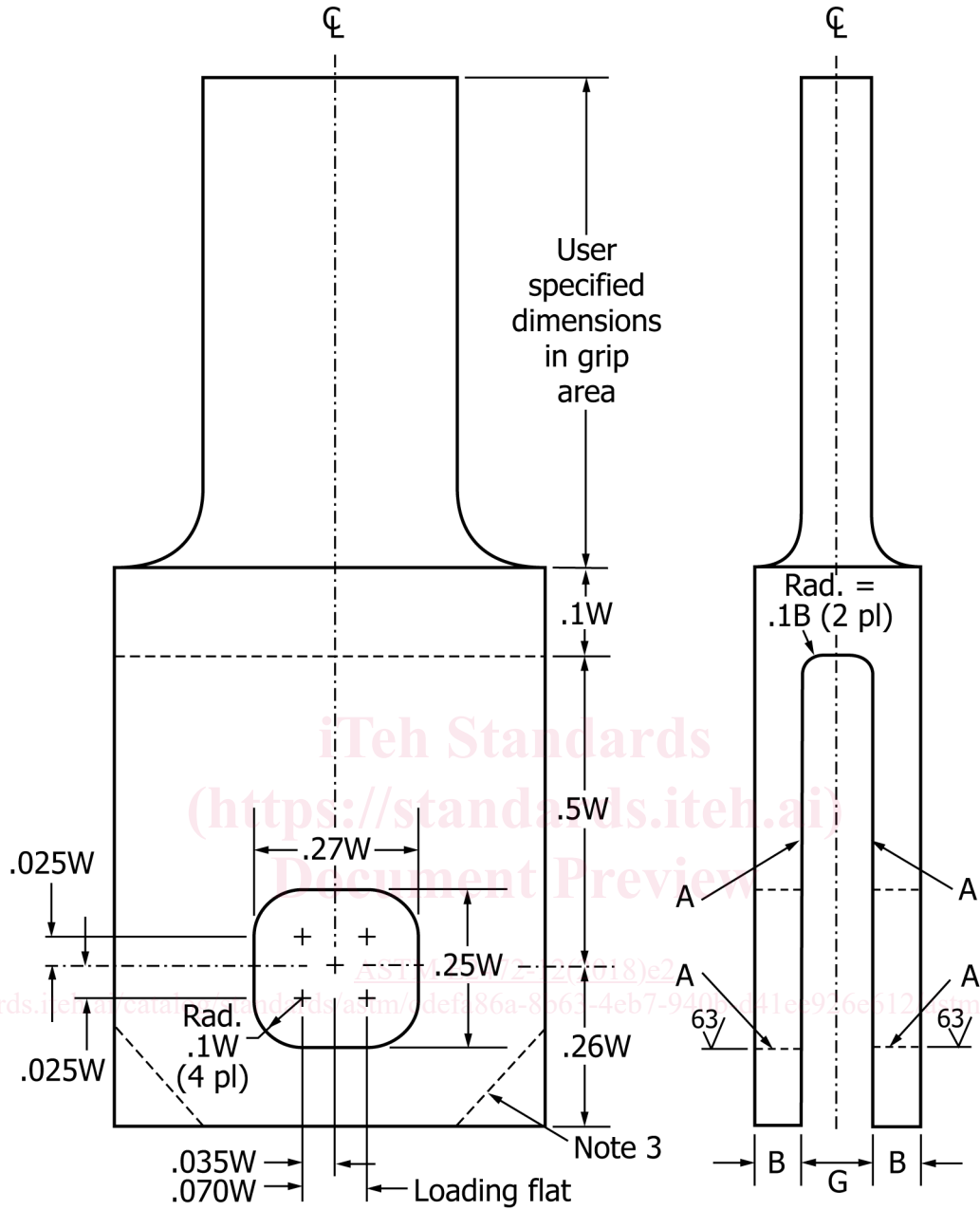

Note 1 - A Surfaces must be flat, in-line and perpendicular, as applicable, to within 0.05 mm (0.002 in.) T.I.R. (Total Indicator Reading)

Note 2 - Value of G must include maximum expected specimen thickness, B, plus twice the guide plate thickness, and extra space for free fixture rotation.

Note 3 - Corners may be removed as necessary to accommodate clip gage.

FIG. 1 Clevis for Compact, C(T), Specimen Testing



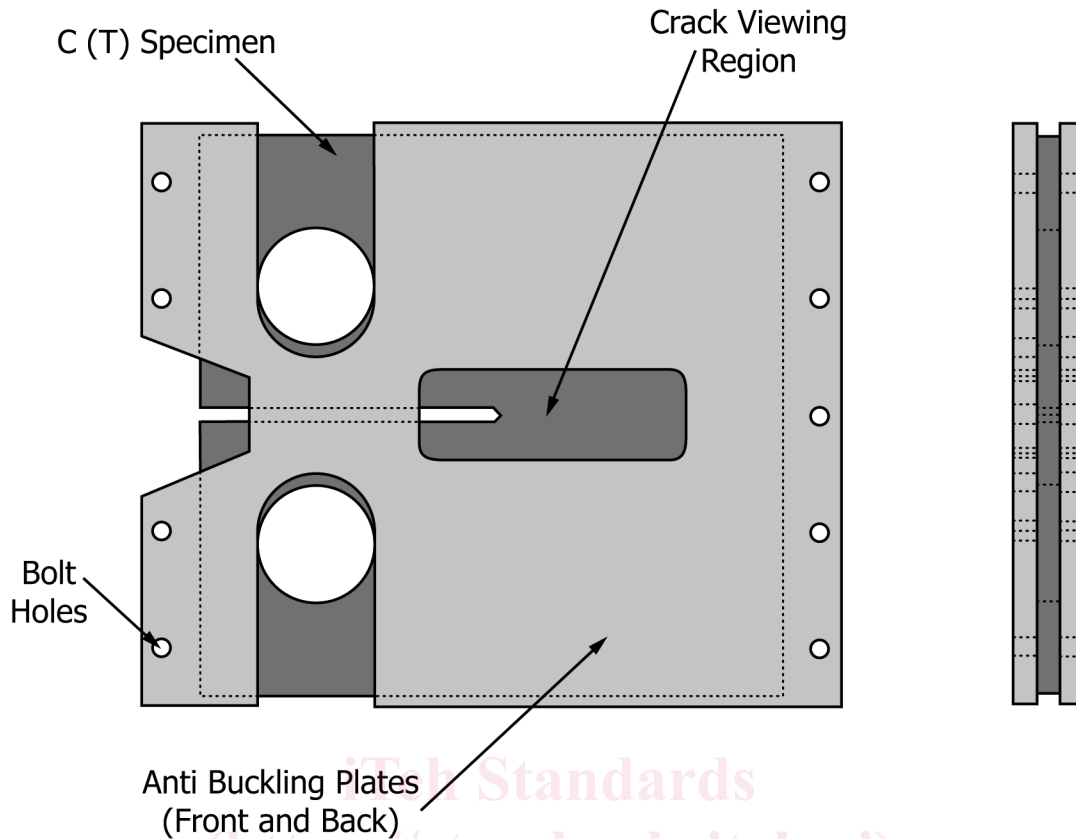

FIG. 2 Compact, C(T), Specimen with Anti-Buckling Guides

with widths ( $2W$ ) larger than about 600 mm. As shown in Fig. 3, gap(s) are left in the anti-buckling plates on either one or both sides of the specimen to allow for the monitoring and measuring of crack extension and the crack-tip-opening angles, and  $\delta_5$ . Measurement of crack-mouth-opening displacements using a clip gage may also be made to determine crack size using the unloading compliance method.

6.4 *Crack Extension Measurement*—Several methods can be used to monitor and measure crack extension: (1) direct optical method, (2) unloading compliance method, (3) electric-potential-drop method, and (4) multiple-specimen method. Indirect crack extension measurement techniques, such as unloading compliance and electric-potential-drop methods may be used in place of (or to complement) the direct optical method to provide a measure of average through-the-thickness crack extension. The multiple-specimen method is used to provide information on the extent of tunneling and to determine a three-point ( $B \leq 5$  mm) or five-point ( $B > 5$  mm) weighted average crack extension.

6.4.1 *Direct Optical Method*—The direct optical method measures the crack size and crack extension on the specimen free surface using optical microscopes. It should be noted that in thin-sheet materials and low constraint specimens, the crack extension observed on the free surface of the specimen may be significantly less than that on the interior of the specimen due to the effects of crack tunneling. This must be kept in mind if direct optical techniques are used to monitor and measure free-surface crack extension.

6.4.2 *Unloading Compliance Method*—By the unloading compliance method, a specimen is partially unloaded and then reloaded at specified intervals during the test. The unloading slopes, which tend to be linear and independent of prior plastic deformation, are used to estimate the crack size at each unloading from analytical elastic compliance relationships. The specimen compliance is determined from either crack-mouth-opening or force-line compliance, and the crack size is estimated using compliance equations (see Test Methods E647 and E1820). If the displacement is measured at an alternative point, then the appropriate compliance function must be developed and utilized. Errors may occur in the compliance measurement as a result of displacement-gage transducer non-linearity. Significant improvement in accuracy can be achieved by curve-fitting the lowest-order polynomial function possible through the calibration data. This method is ideally suited to computer control and subsequent analysis of the test data. However, it should be noted that the method requires careful experimentation and sophisticated test equipment in order to realize its full capability.

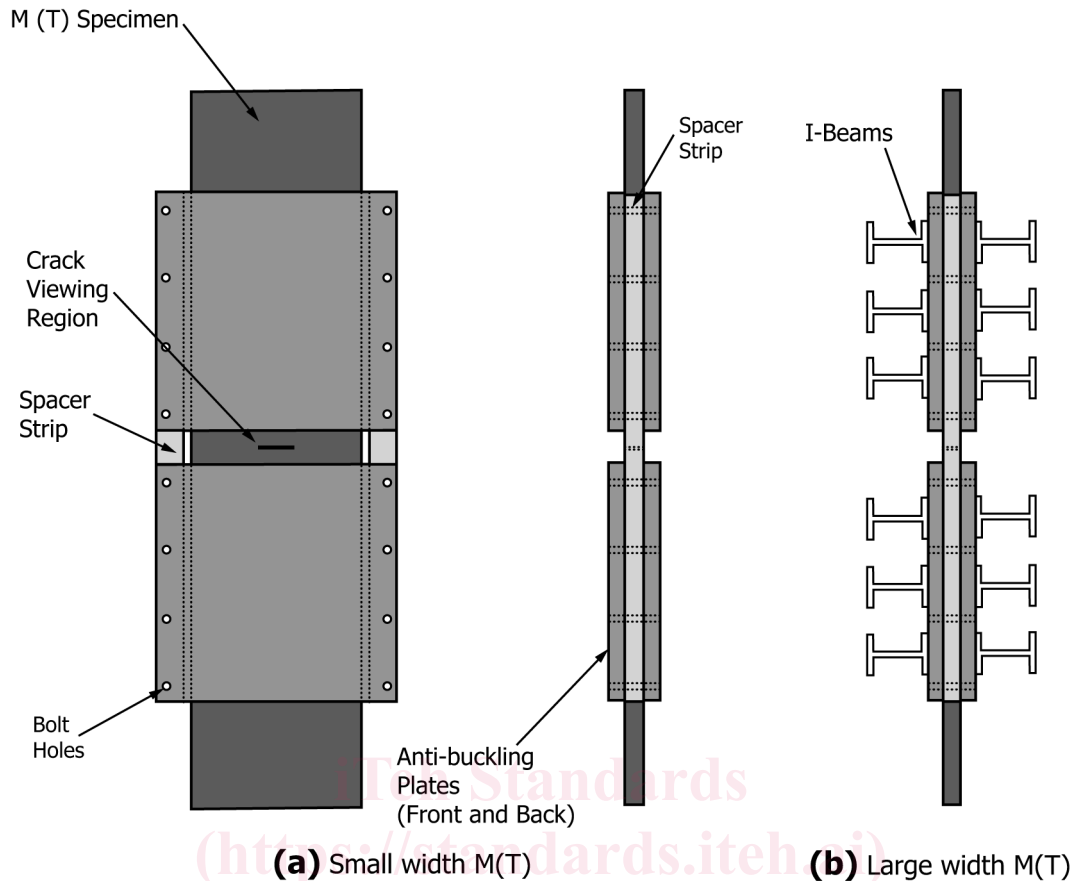

FIG. 3 Middle-Crack-Tension, M(T), Specimen with Anti-Buckling Guides

6.4.3 *Electric Potential Drop Method*—The electrical potential method (13-16) relies on the fact that the distribution of electrical potential in the vicinity of a crack changes with crack extension. With suitable instrumentation, the changes in potential can be detected and calibrated to provide an estimate of increase in crack size. The applied potential is either direct or alternating and the procedure referred to as either the D.C. or the A.C. potential technique, respectively. This method is ideally suited to computer control and subsequent analysis of the test data. However, it should be noted that the method requires careful experimentation and sophisticated test equipment in order to realize its full capability. (See ISO 12135 and Test Method E647 for descriptions of the electric-potential drop methods for the C(T) specimen.)

6.4.4 *Multiple-Specimen Method*—The multiple-specimen method relies on fatigue marking, heat-tinting, or other means to mark the crack front after stable tearing. The multiple-specimen method is used to provide information on the extent of tunneling and to determine a three-point ( $B \leq 5$  mm) or five-point ( $B > 5$  mm) weighted average crack extension.

6.5 *Force Measurement*—The sensitivity of the force-sensing device shall be sufficient to avoid distortion caused by over amplification. The combination of force sensing device and recording system shall permit the maximum force ( $P$ ) to be determined from the test record within an accuracy of  $\pm 1$  %.

6.6 *Displacement and Angle Measuring Technique*—This test method covers the characterization of resistance to stable crack extension in fatigue pre-cracked (at low  $\Delta K$  levels), low-constraint test specimens. Two methods are introduced to provide this characterization, the first is based on the crack-tip-opening angle (CTOA),  $\psi$ , and the second is based on a measure of crack-opening displacement (COD),  $\delta_5$ . Both methods may employ either a single-specimen or multiple-specimen procedure. In the following sections, these two characterizations techniques will be discussed in parallel.

6.6.1 *Crack-Tip-Opening Angle Measurement*—This procedure involves the displacement-controlled loading of a fatigue pre-cracked, low-constraint specimen, C(T) or M(T), while simultaneously measuring the applied force ( $P$ ), crack extension ( $\Delta a$ ) and crack-tip-opening angle (CTOA) measured 1 mm behind the current crack tip. Several methods can be used to determine



CTOA: (1) direct measurements during stable tearing using optical methods (8, 9), (2) post test measurements (microtopography) (17-19), (3) finite element analyses (6-8, 20-26), and (4) indirect determination using  $\delta_5$ . The two techniques that are used for direct measurement of  $\psi$  (CTOA) during stable tearing of cracks are the Optical Microscopy (OM) (8) and Digital Image Correlation (DIC) (8, 9) methods. Both of these methods produce nearly identical CTOA results (8, 20).

6.6.1.1 *Optical Microscopy (OM) Method*—This method includes: (a) a long focal length microscope, (b) a high-resolution video camera with resolution of 512 by 512 pixels (or better) to obtain images of the stably tearing crack, (c) a recording mechanism to store the images (PC or video recorder), and (d) a personal computer with both monitor and software to precisely control the three-dimensional positioning of the long focal length microscope and also to analyze the images to obtain CTOA. A transverse magnification of approximately 320 pixels per mm has been shown to provide satisfactory results. To obtain clear images of the crack using OM, the surface of the specimen must be polished to a mirror finish and lighting of the crack region must be carefully controlled so that the crack tip region has optimum contrast and clarity. Recommended procedures to measure CTOA using this method will be discussed in 9.1.1 of this document.

6.6.1.2 *Digital Image Correlation (DIC) Method*—This method includes: (a) a video camera, (b) a lens system to obtain the appropriate level of magnification (for example, a 200 mm lens with 2× magnifier and several extension tubes has been used effectively in previous applications), (c) translation stage for positioning of the video camera and following the growing crack, (d) video monitor to view the crack tip region, (e) video board to digitize images, and (f) a microcomputer with software for controlling the image acquisition process and storing images. The DIC method is similar to previously reported image correlation systems, except that in this case the video camera is translated parallel to the specimen surface during the experiment so that the current crack tip remains within the field of view. Note that, after each translation of the video camera, the current image and previous image overlap by at least 50 pixels so that a continuous record of crack size is maintained if the crack grows beyond the current field of view. Recommended procedures to measure CTOA using this method will be discussed in 9.1.2 of this document.

6.6.2 *Crack-Opening Displacement,  $\delta_5$ , Measurement*—This procedure involves the displacement-controlled loading of a fatigue pre-cracked, low-constraint specimen, [C(T) or M(T)], while simultaneously measuring the applied force ( $P$ ), crack extension ( $\Delta a$ ), and crack-opening displacement ( $\delta_5$ ) measured at the original fatigue crack tip location.

6.6.2.1 *Clip-Gage Method*—This method includes a displacement gage for the determination of  $\delta_5$  at the original fatigue crack tip location and shall have an electrical output that represents the displacement between two precisely located gage positions 5-mm apart and spanning the crack at the original fatigue crack tip location. The basic arrangement for measuring  $\delta_5$  is shown in Fig. 4. The area around the expected fatigue pre-crack path is to be polished. After fatigue pre-cracking, Vickers hardness indentations are placed 2.5 mm to either side of the crack tip to give a gage length of 5 mm. A clip gage with needle tips is seated into the hardness indentations and held against the specimen using the lever mechanism shown in Fig. 5 for the compact specimen. Similar arrangements and clip-gage fixtures are used for middle-crack-tension specimens. The recommended displacement gage configuration and dimensions are shown in Fig. 6. The displacement gage has a working range of not more than twice the displacement expected during the test. When the expected displacement is less than 3.75 mm, the gage recommended in Fig. 6 may be used. When a greater working range is needed, an enlarged gage or the optical methods are recommended. Accuracy shall be within  $\pm 1\%$  of the full working range. In calibration, the maximum deviation of the individual data points from a linear fit to the data shall be less than  $\pm 0.3\%$  of the working range of the gage. Vickers hardness indentations at 5-mm gage length are required for seating the gage. The displacement gage should be removed from the specimen before the specimen fails. Recommended procedures to measure  $\delta_5$ -resistance curves using this method will be discussed in 9.2 of this document.

6.6.2.2 *Digital Image Correlation (DIC) Method*—This method includes: (a) a video camera, (b) a lens system to obtain the appropriate level of magnification (for example, a 200 mm lens with 2× magnifier and several extension tubes has been used effectively in previous applications), (c) a translation stage for positioning of the video camera and following the growing crack, (d) video monitor to view the crack tip region, (e) video board to digitize images, and (f) microcomputer with software for controlling the image acquisition process and storing images. The DIC method is similar to previously reported systems, except that the video camera remains stationary so that the original crack tip remains within the field of view. Recommended procedures to measure  $\delta_5$ -resistance curves using this method will be discussed in 9.2 of this document.

6.6.2.3 *Optical Microscopy (OM) Method*—This method includes: (a) a long focal length microscope positioned at the original crack-tip location, (b) a high-resolution video camera with resolution of 512 by 512 pixels (or better) to obtain images of the displacement field, (c) a recording mechanism to store the images (PC or video recorder), and (d) a personal computer with both monitor and software to measure the  $\delta_5$ -displacement. After fatigue pre-cracking, Vickers hardness indentations are placed 2.5 mm to either side of the crack tip to give a gage length of 5 mm. The displacement of the indentation marks is measured as a function of the applied force and crack extension. Recommended procedures to measure  $\delta_5$ -resistance curves using this method will be discussed in 9.2 of this document.

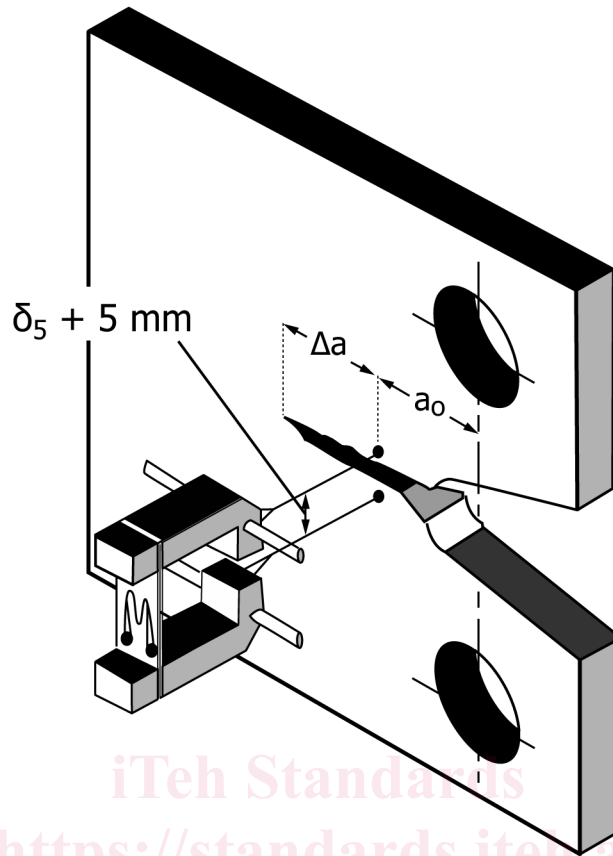

FIG. 4 Basic Clip Gage and Specimen Arrangement for Measuring  $\delta_5$

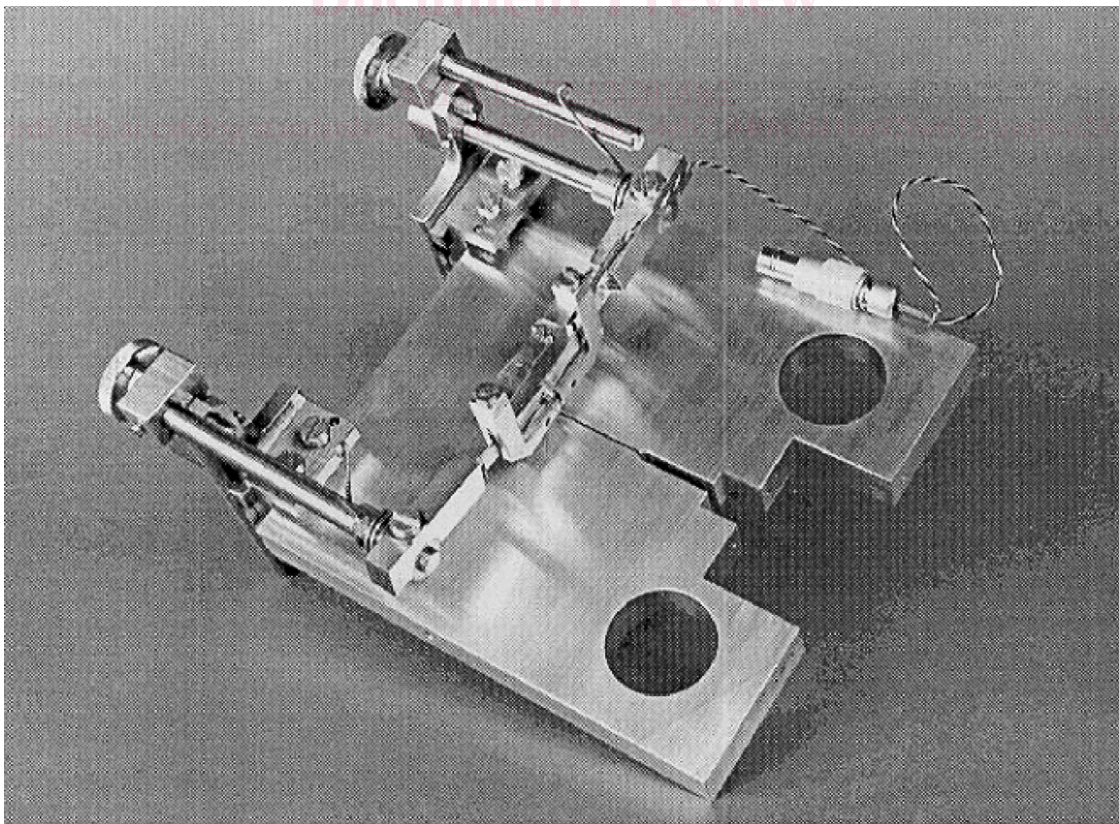

FIG. 5 Fixtures for Attachment of the  $\delta_5$  Clip Gage to Compact Specimen

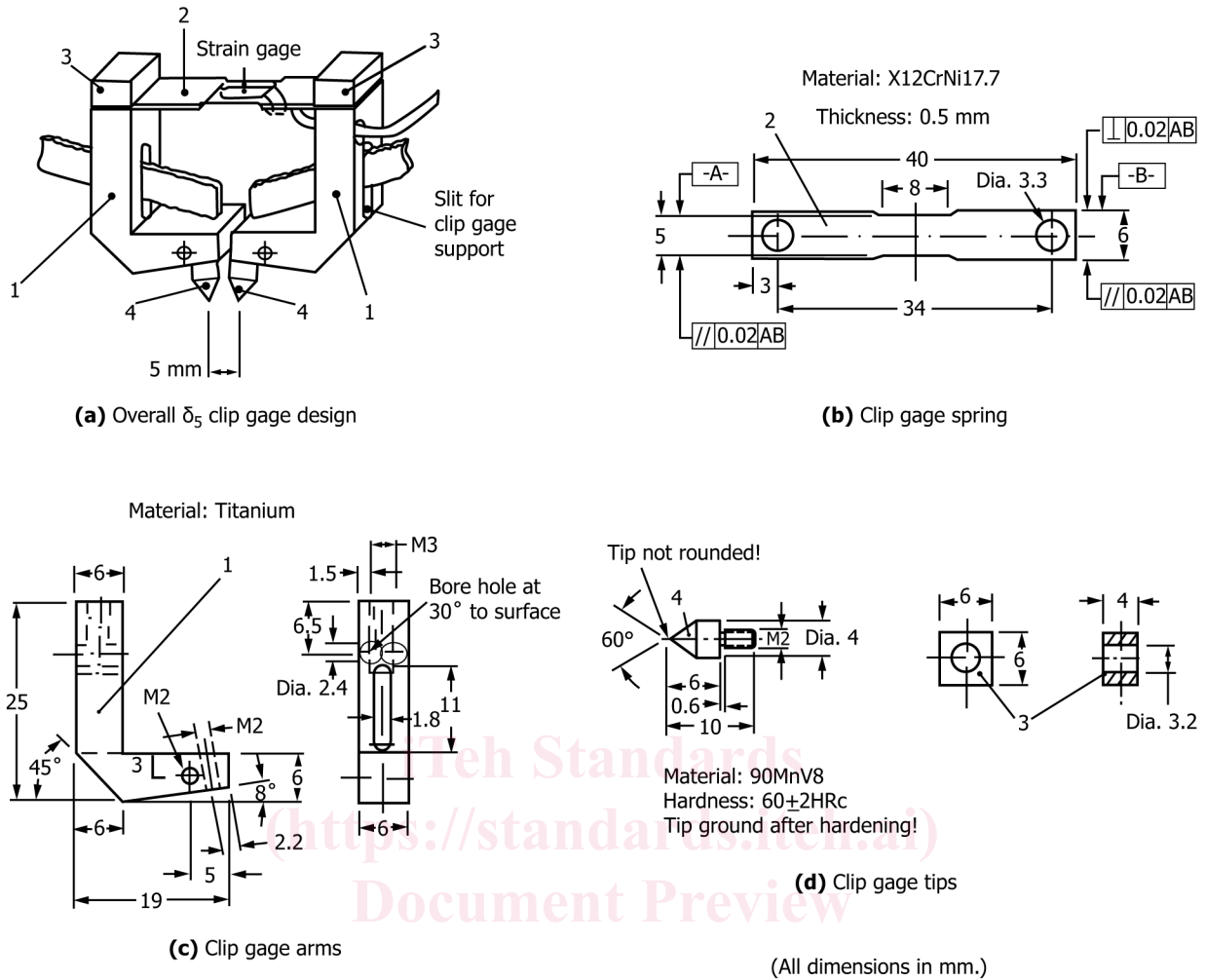

FIG. 6 Crack-Opening Displacement,  $\delta_5$ , Clip Gage Design

<https://standards.iteh.ai/catalog/standards/astm/cdefa86a-8b63-4eb7-940b-d41ee926e612/astm-e2472-122018e2>

## 7. Specimen Configuration, Dimensions, and Preparation

7.1 Materials that can be evaluated by this standard are not limited by strength, thickness, or toughness, if the crack-size-to-thickness ( $a/B$ ) ratio or ligament-to-thickness ( $b/B$ ) ratio are equal to or greater than 4, which ensures relatively low and similar global crack-front constraint for both the C(T) and M(T) specimens.

NOTE 2—The total width of the M(T) specimen is defined as  $2W$ .

7.2 *Specimen Configurations*—The crack configurations of the standard specimens are shown in Annex A1 and Annex A2. To produce a reliable critical CTOA ( $\psi_c$ ) and a large amount of the  $\delta_5$ -resistance curve, the specimens have a minimum width ( $W$ ) of 150 mm.

7.3 *Crack Plane Orientation*—The crack plane orientation shall be considered in preparing the test specimen. The orientation of the crack plane in the material of interest can affect the critical crack-opening displacement parameters considered in this standard (see Terminology E1823).

7.4 *Specimen Pre-cracking*—All specimens shall be pre-cracked in fatigue. Experience has shown that it is impractical to obtain a reproducibly sharp, narrow machined notch that will simulate a natural crack well enough to provide a satisfactory fracture toughness test result. The most effective artifice for this purpose is a narrow notch from which extends a comparatively short fatigue crack, called the pre-crack. (A fatigue pre-crack is produced by cyclically loading the notched specimen for a number of cycles usually between about  $10^4$  and  $10^6$  depending on specimen size, notch preparation, and stress intensity level.) The