



Designation: ~~D8131/D8131M – 17~~^{e1} D8131/D8131M – 23

Standard Practice for Tensile Properties of Tapered and Stepped Joints of Polymer Matrix Composite Laminates¹

This standard is issued under the fixed designation D8131/D8131M; the number immediately following the designation indicates the year of original adoption or, in the case of revision, the year of last revision. A number in parentheses indicates the year of last reapproval. A superscript epsilon (ϵ) indicates an editorial change since the last revision or reapproval.

^{e1} NOTE—Editorial changes made in September 2017.

1. Scope

1.1 This test practice defines the procedure for determination of the tensile strength of a tapered or stepped joint of polymer matrix composite materials. It is applicable to secondary bonded or co-bonded laminates with either unidirectional plies or woven fabric reinforcements. The materials to be bonded may be different material systems. In the bondline, a separate adhesive material may or may not be used (example: adhesives may be used with a prepreg system or may not be used with a wet lay-up repair system). The range of acceptable test laminates and thicknesses is described in 8.2.1.

1.2 This practice supplements Test Method D3039/D3039M for tensile loading. Several important test specimen parameters (for example, joint length, ply overlaps, step depth, and taper ratio) are not mandated by this practice, however, these parameters are required to be specified and reported to support repeatable results.

1.3 Unidirectional (0° ply orientation) tape composites, textile composites, as well as multidirectional composite laminates, can be tested.

1.4 Units—The values stated in either SI units or inch-pound units are to be regarded separately as standard. The values stated in each system are not necessarily exact equivalents; therefore, to ensure conformance with the standard, each system shall be used independently of the other, and values from the two systems shall not be combined.

1.4.1 Within the text the inch-pound units are shown in brackets. ~~The values stated in each system are not exact equivalents; therefore, each system must be used independently of the other. Combining values from the two systems may result in nonconformance with the standard~~

1.5 *This standard does not purport to address all of the safety concerns, if any, associated with its use. It is the responsibility of the user of this standard to establish appropriate safety, health, and environmental practices and determine the applicability of regulatory limitations prior to use.*

1.6 *This international standard was developed in accordance with internationally recognized principles on standardization established in the Decision on Principles for the Development of International Standards, Guides and Recommendations issued by the World Trade Organization Technical Barriers to Trade (TBT) Committee.*

¹ This practice is under the jurisdiction of ASTM Committee D30 on Composite Materials and is the direct responsibility of Subcommittee D30.05 on Structural Test Methods.

Current edition approved Aug. 1, 2017/May 1, 2023. Published August 2017/June 2023. Originally approved in 2017. Last previous edition approved in 2017 as D8131/D8131M – 17^{e1}. DOI: ~~10.1520/D8131-D8131M-17E01~~. 10.1520/D8131_D8131M-23.



2. Referenced Documents

2.1 ASTM Standards:²

D792 Test Methods for Density and Specific Gravity (Relative Density) of Plastics by Displacement

D883 Terminology Relating to Plastics

D2584 Test Method for Ignition Loss of Cured Reinforced Resins

D2734 Test Methods for Void Content of Reinforced Plastics

D3039/D3039M Test Method for Tensile Properties of Polymer Matrix Composite Materials

D3171 Test Methods for Constituent Content of Composite Materials

D3878 Terminology for Composite Materials

D5229/D5229M Test Method for Moisture Absorption Properties and Equilibrium Conditioning of Polymer Matrix Composite Materials

E4 Practices for Force Calibration and Verification of Testing Machines

E6 Terminology Relating to Methods of Mechanical Testing

E122 Practice for Calculating Sample Size to Estimate, With Specified Precision, the Average for a Characteristic of a Lot or Process

E177 Practice for Use of the Terms Precision and Bias in ASTM Test Methods

E456 Terminology Relating to Quality and Statistics

E2533 Guide for Nondestructive Examination of Polymer Matrix Composites Used in Aerospace Applications

2.2 Other Documents:³

CMH-17 Composite Materials Handbook-17 – Volume I

3. Terminology

3.1 Terminology D3878 defines terms relating to high-modulus fibers and their composites. Terminology D883 defines terms relating to plastics. Terminology E6 defines terms relating to mechanical testing. Terminology E456 and Practice E177 define terms relating to statistics. In the event of a conflict between terms, Terminology D3878 shall have precedence over the other terminology standards.

NOTE 1—If the term represents a physical quantity, its analytical dimensions are stated immediately following the term (or letter symbol) in fundamental dimension form, using the following ASTM standard symbology for fundamental dimensions, shown within square brackets: [M] for mass, [L] for length, [T] for time, [θ] for thermodynamic temperature, and [nd] for nondimensional quantities. Use of these symbols is restricted to analytical dimensions when used with square brackets, as the symbols may have other definitions when used without the brackets.

3.2 Definitions of Terms Specific to This Standard:

3.2.1 *co-bonded (repair) laminate*—*laminate, n*—the co-bonded laminate is the laminate that is bonded to the parent pre-cured laminate and cured in a second cure cycle.

3.2.2 *joint tensile strength*—*strength, n*—ultimate tensile force experienced by the test specimen divided by the initial width of the joint area and the nominal thickness of the parent laminate.

3.2.3 *nominal value*—*value, n*—a value, existing in name only, assigned to a measurable property for the purpose of convenient designation. Tolerances may be applied to a nominal value to define an acceptable range for the property.

3.2.4 *parent laminate*—*laminate, n*—the parent laminate is the laminate that is cured during the first cure cycle.

3.2.5 *secondary bonded (repair) laminate*—*laminate, n*—the secondary bonded laminate is a pre-cured laminate that is bonded to the parent pre-cured laminate using a separate adhesive material (sometimes referred to as a pre-cured patch repair).

3.3 Symbols:

3.3.1 *CV*—sample coefficient of variation, in percent

3.3.2 F_p^{tu} —ultimate tensile strength, based on parent laminate thickness

² For referenced ASTM standards, visit the ASTM website, www.astm.org, or contact ASTM Customer Service at service@astm.org. For *Annual Book of ASTM Standards* volume information, refer to the standard's Document Summary page on the ASTM website.

³ Available for purchase in print and e-book format from SAE International, <http://books.sae.org/r-422/>.



3.3.3 F_r^{tu} —ultimate tensile strength, based on repair laminate thickness

3.3.4 h_p —specimen nominal parent laminate thickness as specified by the test requestor (nominal ply thickness may be available from the relevant material specification)

3.3.5 h_r —specimen nominal repair laminate thickness as specified by the test requestor (nominal ply thickness may be available from the relevant material specification)

3.3.6 N_j —ultimate joint running force per ply

3.3.7 n —number of specimens

3.3.8 n_p —number of parent laminate plies

3.3.9 P_f —maximum force carried by test specimen at failure

3.3.10 S_{n-1} —standard deviation statistic of a sample population for a given property

3.3.11 w —specimen width

3.3.12 x_i —test result for an individual coupon from the sample population for a given property

3.3.13 \bar{x} —mean or average (estimate of mean) of a sample population for a given property

4. Summary of Practice

4.1 *Tapered or Stepped Joint Tensile Strength*—In accordance with Test Method D3039/D3039M, but using a tapered or stepped joint configured specimen (Fig. 1 or Fig. 2), perform a uniaxial tension test of the composite laminate joint specimen.

5. Significance and Use

<https://standards.iteh.ai/catalog/standards/sist/8197dfe2-495a-49e5-a812-259e26bb2a1e/astm-d8131-d8131m-23>

5.1 This test practice is designed to produce tensile property data for material specifications, research and development, quality assurance, and structural design and analysis. Factors that influence the tensile response and should therefore be reported include the following: materials (laminates and adhesive), methods of material preparation including surface preparation prior to bonding, lay-ups, specimen stacking sequence, joint taper ratio or step length, ply overlap length, material relative thicknesses and stiffness of the parent and repair laminates, adhesive bond stiffness, specimen preparation, specimen conditioning, environment of testing, specimen alignment and gripping, speed of testing, time at temperature, void content, and volume percent reinforcement. Properties in the test direction, which may be obtained from this test practice, include the following:

5.1.1 Ultimate tensile strength (based on the nominal parent material thickness), (F_p^{tu}).

5.1.2 Ultimate tensile strength (based on the nominal repair material thickness), (F_r^{tu}).

5.1.3 Ultimate running force per repair ply, (N_j).

6. Interferences

6.1 *Material and Specimen Preparation*—Poor material fabrication practices, lack of control of fiber alignment, and damage induced by improper coupon machining are known causes of high material data scatter in composites. For the bonded joint specimens, the quality of the co-cured laminate (ply positioning, lengths, impregnation for wet lay-up material systems), lack of orientation control of the parent laminate or pre-cured patch, and quality of the bond between the parent and pre-cured or co-cured bonded laminates will have significant effects on the test results.

6.2 *Gripping*—A high percentage of grip-induced failures, especially when combined with high material data scatter, is an

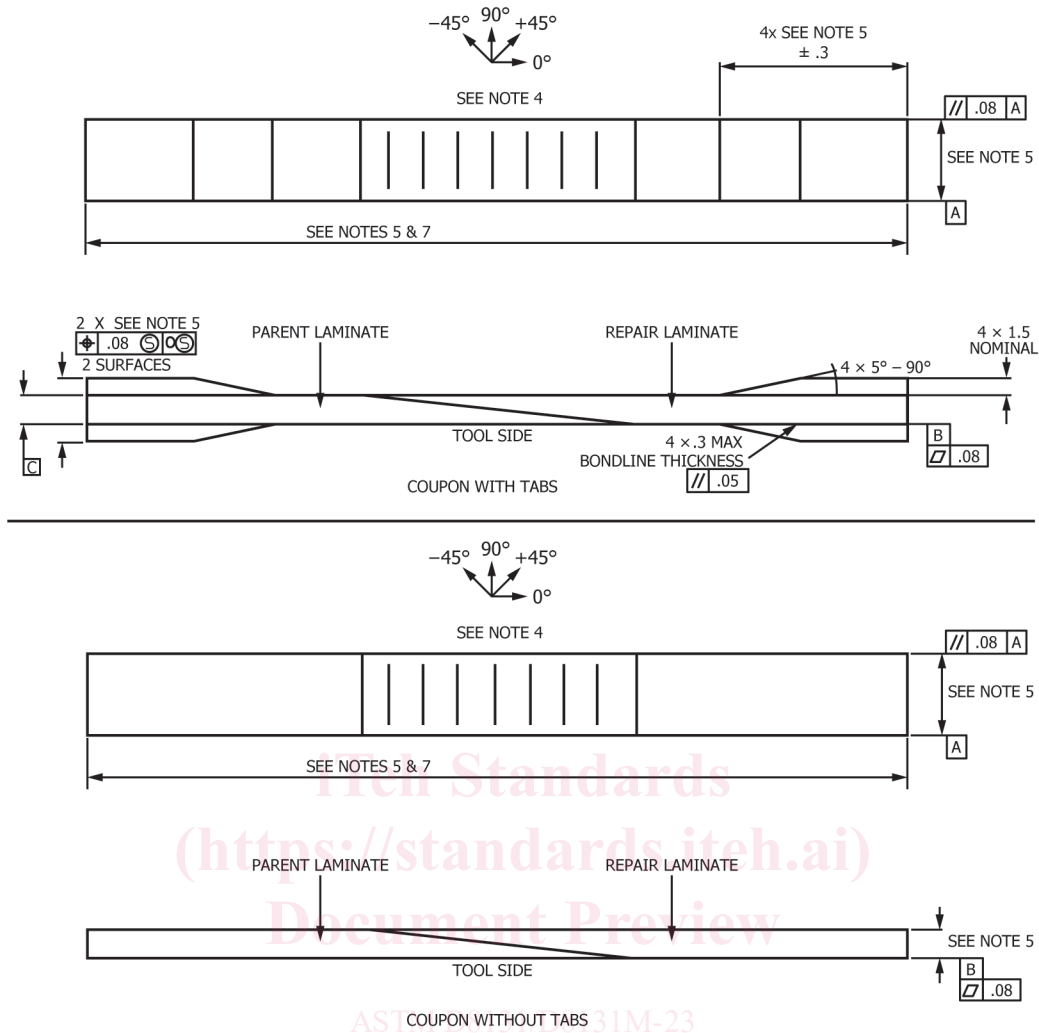

Notes:

- 1) Interpret drawing in accordance with ANSI Y14.5M-1982, subject to the following:
- 2) All dimensions in millimeters with decimal tolerances as follows:

No Decimal	.X	.XX
±3	±1	±.3
- 3) All angles have a tolerance of ±5°.
- 4) Ply orientation direction tolerance relative to -A- within ±.5°.
- 5) Finish on machine edges not to exceed 1.6√ (symbology in accordance with ASA B46.1, with roughness height in micrometers).
- 6) Values to be provided for the following, subject to any ranges shown in the field of drawing: material, lay-up, ply orientation reference relative to -A-, overall length, gage length, coupon thickness, tab material, tab thickness, tab length, tab bevel angle, tab adhesive.
- 7) Repair specimen length design should not exceed scarf joint length by more than 20 %.

FIG. 1 Tensile Tapered and Stepped Joint Specimen – Geometry (SI)

indicator of specimen gripping problems. Specimen gripping methods are discussed further in Test Method D3039/D3039M. Specimen shall not be gripped within 25 mm [1.0 in.] of the bondline (joint) area.

6.3 *System Alignment*—Excessive bending will cause premature failure, as well as highly inappropriate load-versus-deflection response. Every effort should be made to eliminate excess bending from the test system. Bending may occur as a result of misaligned grips or from specimens themselves if improperly installed in the grips or out-of-tolerance caused by poor specimen preparation. If there are differences in material thickness and stiffness of the parent versus repair laminates, it may be necessary to intentionally induce distortion and misalignment upon gripping or to employ the use of a shim(s) on the thinner part of the specimen and accept the induced moment. If there is any doubt as to the alignment inherent in a given test machine, then the alignment should be checked as discussed in Test Method D3039/D3039M.

6.4 *Specimen Design*—The bonded joint test specimen involves a parent and a repair laminate. These two laminates typically do

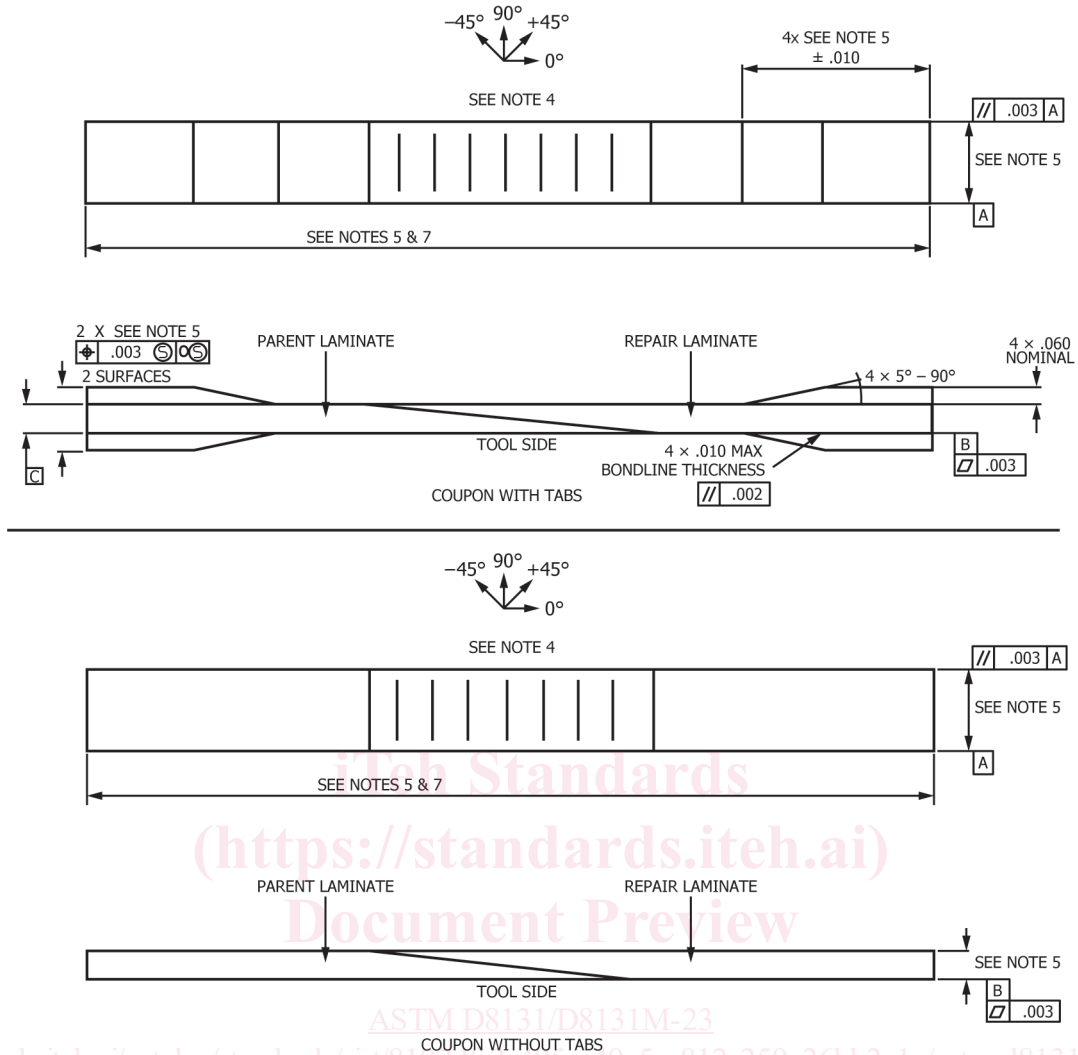

Notes:

- 1) Interpret drawing in accordance with ANSI Y14.5M-1982, subject to the following:
- 2) All dimensions in inches with decimal tolerances as follows:

No Decimal	.X	.XX
±.1	±.03	±.01

- 3) All angles have a tolerance of $\pm 5^\circ$.
- 4) Ply orientation direction tolerance relative to -A- within $\pm 5^\circ$.
- 5) Finish on machine edges not to exceed $64\sqrt{\text{ }}$ (symbology in accordance with ASA B46.1, with roughness height in microinches).
- 6) Values to be provided for the following, subject to any ranges shown in the field of drawing: material, lay-up, ply orientation reference relative to -A-, overall length, gage length, coupon thickness, tab material, tab thickness, tab length, tab bevel angle, tab adhesive.
- 7) Repair specimen length design should not exceed scarf joint length by more than 20 %.

FIG. 2 Tensile Tapered and Stepped Joint Specimen – Geometry (Inch-Pound)

not use the same material system. There are a number of variables and factors which influence the selection of the repair laminate lay-up relative to the parent laminate. Generally the repair lay-up is designed to match or slightly exceed the stiffness of the parent laminate, and ideally the repair material type (fabric or tape) and the ply thicknesses are the same as for the parent material. When they are different, repair design compromises are necessary to obtain sufficient repair stiffness and strength while not making the repair thicker than the parent laminate. Details of repair design are beyond the scope of this test practice. When filler plies or extra repair plies are used, or when the repair material thicknesses do not match the parent material thicknesses, a difference in joint test specimen thickness on the two ends will occur, leading to some induced bending, even if shims are applied. Also, any unbalance or asymmetry in the repair lay-up from filler plies, the repair laminate, or from extra repair plies may also lead to some induced bending. The results from this test practice are reported as simple stress and force-per-width values; the joint specimen design will influence the validity of these reported results for use with bonded repair analysis methods.

6.4.1 *Step Joint Filler Plies*—The stepped joint specimen should have a filler ply to avoid waviness in the repair plies. The filler ply should ideally be the same thickness as the bottom ply in the parent laminate. The standard test specimen configuration in this practice for unidirectional tape materials uses a +45 ply as the filler ply; this may induce some bending or twisting in the specimen under load. If an equivalent thickness fabric repair material is available, that could be used for the filler ply to provide a balanced lay-up.

6.5 *Edge Effects in Angle Ply Laminates*—Premature failure can occur as a result of edge softening in laminates containing off-axis plies. Because of this, the strength for angle ply laminates can be lower than expected. For multidirectional laminates containing significant axial fibers, the effect is not as significant.

6.6 *Environment*—Results are affected by the environmental conditions under which the tests are conducted. Laminates tested in various environments can exhibit significant differences in both failure force and failure mode. Experience has demonstrated that cold-temperature environments can be critical for laminate tensile strength, however, elevated-temperature, humid environments can also be critical. The critical environmental condition for bonded joint specimens is complicated by having multiple materials in the test specimens. The failure modes may change between laminate tensile modes, bondline modes or laminate interfacial modes as the environmental condition changes. Critical environments must be assessed independently for each material system combination, joint configuration, and stacking sequence tested.

6.7 *Failure Mode*—For a valid test, final failure of the specimen must occur within the gage section. Which failure modes are deemed acceptable will be governed by the particular material, configuration, and application (see 11.5 and Fig. 5).

7. Apparatus

7.1 *General Apparatus*—General apparatus shall be in accordance with Test Method D3039/D3039M.

7.2 *Testing Machine*—The testing machine shall be in conformance with Practices E4 and shall satisfy all requirements defined in Test Method D3039/D3039M.

7.3 *Conditioning Chamber*—When conditioning materials in other than ambient laboratory environments, a temperature/moisture-level controlled environmental conditioning chamber is required that shall be capable of maintaining the required relative temperature to within ± 3 °C [± 5 °F] and the required relative vapor level to within ± 3 %. Chamber conditions shall be monitored either on an automated continuous basis or on a manual basis at regular intervals.

7.4 *Environmental Chamber*—A chamber capable of enclosing the test fixture and specimen while they are mounted in the testing machine, and capable of achieving the specified heating/cooling rates, test temperatures, and environments, shall be used when nonambient conditions are required during testing. This chamber shall be capable of maintaining the gage section of the test specimen within ± 3 °C [± 5 °F] of the required test temperature during the mechanical test. In addition, the chamber may have to be capable of maintaining environmental conditions such as fluid exposure or relative humidity during the test.

7.5 *Data Acquisition Equipment*—Equipment capable of continuous recording of force or displacement data, or both, is required.

8. Sampling and Test Specimens

8.1 *Sampling*—Test at least five specimens per test condition unless valid results can be gained through the use of fewer specimens, such as in the case of a designed experiment. For statistically significant data, the procedures outlined in Practice E122 should be consulted. The method of sampling shall be reported.

8.2 *Geometry*—The test specimen is a rectangular strip of the composite to be tested with either a tapered or stepped joint, as shown in Figs. 1-3 (tapered) or Fig. 1, Fig. 2, and Fig. 4 (stepped). The standard specimen joint geometries are listed in the following subsections. Non-standard specimen configurations may be tested.

8.2.1 *Tapered Joint Standard Specimen*—The standard tapered specimen is defined in Table 1. The specimen joint length is equal to the taper ratio times the parent laminate thickness. For additional description, dimensions, and tolerances see Figs. 1-3.

8.2.2 *Tapered Joint Standard Specimen Length*—The recommended standard taper joint specimen length is defined as the repair

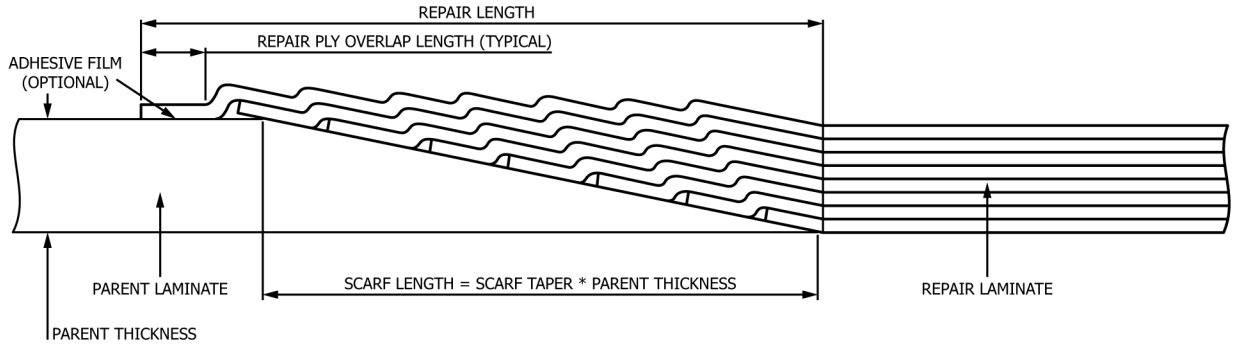

FIG. 3 Close-Up of Tensile Tapered Joint Specimen – Geometry

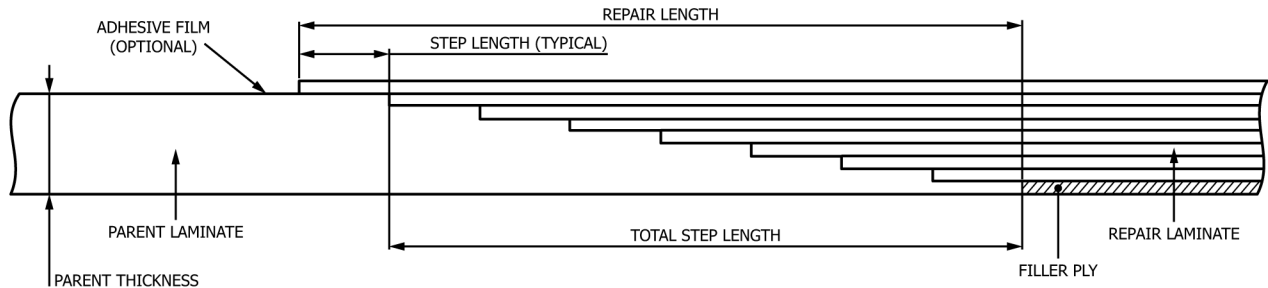

FIG. 4 Close-Up of Tensile Stepped Joint Specimen – Geometry

TABLE 1 Tensile Tapered Joint Standard Specimen Geometry Requirements

Specimen Type	Specimen Lay-Up – Parent and Repair	Taper Ratio	Repair Ply Overlap Length ^A	Specimen Width	Repair Length ^B
Tapered	[+45°/90°/-45°/0°]s (Tape) or [(0°/90°) (+45°/-45°) (90°/0°) (-45°/+45°)]s (Fabric)	50:1	10 ± 2 mm [0.4 ± 0.08 in.]	25 ± 3 mm [1.0 ± 0.1 in.]	80 ± 3 mm [3.0 ± 0.1 in.]
Tapered	[+45°/90°/-45°/0°]s (Tape) or [(0°/90°) (+45°/-45°) (90°/0°) (-45°/+45°)]s (Fabric)	50:1	10 mm ± 2 mm [0.4 in. ± 0.08 in.]	25 mm ± 3 mm [1.0 in. ± 0.1 in.]	80 mm ± 3 mm [3.0 in. ± 0.1 in.]

^AThe standard repair ply overlap length is designed for a repair ply material thickness less than or equal to 0.2 mm [0.008 in.]. For repair materials with significantly different ply thicknesses, the repair ply overlap length should be adjusted accordingly.

^BFor the standard specimen, the repair length shall be greater than or equal to the scarf length (that is, for parent ply material thicknesses greater than 0.2 mm [0.008 in.], the repair ply overlap will need to be increased or the repair laminate lay-up revised).

length plus a minimum of 25 mm [1.0 in.] on both ends between the end of the repair and the tabs or grips plus the length of the tabbed or gripped area. The recommended tab or grip length is 50 mm [2.0 in.].

8.2.3 *Tapered Joint Non-Standard Specimen*—A number of specimen parameters may be modified by the test requestor provided they are fully documented in the test report. These include the parent and repair material and lay-ups, taper ratio, and repair ply overlap length. Taper ratios for bonded joints are typically between 30:1 and 50:1, with the repair ply overlap length typically rounded up from the value equal to the repair ply thickness divided by the taper ratio. In some applications, taper ratios as low as 20:1 or as high as 100:1 have been used; however outside the 30:1 to 50:1 range it may be difficult to perform the taper sanding or the repair ply lay-up (or both). In many cases the repair material has a different ply thickness from the parent material, which will result in different parent and repair laminate thicknesses and necessitating use of shims or acceptance of a load line offset. Filler plies, additional repair plies, or combinations thereof, if they are representative of actual repair designs, may be included in the test specimen configuration.

8.2.4 *Stepped Joint Standard Specimen*—The standard stepped test specimen is defined in Table 2. A step shall be machined for each ply in the parent laminate. For additional description, dimensions, and tolerances also see Fig. 1, Fig. 2, and Fig. 4. It is recommended that an initial filler ply be added to the overall repair stacking sequence to prevent waviness in the repair plies. The filler ply(s) should be made of the same material as the repair material being used in the stepped specimen and oriented at +45° (Tape) or (+45°/-45°) (Fabric); the filler ply extends the entire length of the repair laminate portion of the specimen.

8.2.5 *Stepped Joint Standard Specimen Length*—The recommended standard stepped joint specimen length is defined as the repair