



## Standard Specification for Paintball Markers<sup>1</sup>

This standard is issued under the fixed designation F2272; the number immediately following the designation indicates the year of original adoption or, in the case of revision, the year of last revision. A number in parentheses indicates the year of last reapproval. A superscript epsilon ( $\epsilon$ ) indicates an editorial change since the last revision or reapproval.

### 1. Scope

1.1 This specification covers paintball markers, which propel a paintball by means of energy released by compressed air, compressed gas, or other means.

1.2 *Limitations*—This specification does not cover non-recreational paintball markers, for example, those used by law enforcement, scientific, military or theatrical entities.

1.3 The values stated in SI units are to be regarded as the standard; the inch-pound units in parentheses are provided for information only.

1.4 The following precautionary caveat pertains only to the test method portion, Section 8, of this specification. *This standard does not purport to address all of the safety concerns, if any, associated with its use. It is the responsibility of the user of this standard to establish appropriate safety, health, and environmental practices and determine the applicability of regulatory limitations prior to use.*

1.5 *This international standard was developed in accordance with internationally recognized principles on standardization established in the Decision on Principles for the Development of International Standards, Guides and Recommendations issued by the World Trade Organization Technical Barriers to Trade (TBT) Committee.*

### 2. Referenced Documents

#### 2.1 ASTM Standards:<sup>2</sup>

[F1776 Specification for Eye Protective Devices for Paintball Sports](#)

[F1979 Specification for Projectiles Used in the Sport of Paintball](#)

#### 2.2 ANSI Standard:

[Z535.1 Safety Color Code](#)<sup>3</sup>

### 3. Terminology

#### 3.1 Definitions of Terms Specific to This Standard:

3.1.1 *auto-trigger*—a trigger which, when held in the discharge position, will automatically cause the paintball marker to discharge when the pump or bolt action is manipulated.

<sup>1</sup> This specification is under the jurisdiction of ASTM Committee F08 on Sports Equipment, Playing Surfaces, and Facilities and is the direct responsibility of Subcommittee F08.24 on Paintball and Equipment.

Current edition approved May 1, 2021; June 1, 2023. Published July 2021; June 2023. Originally approved in 2003. Last previous edition approved in 2017 as F2272 – 13 (2017); (2021). DOI: 10.1520/F2272-13R21-10.1520/F2272-23.

<sup>2</sup> For referenced ASTM standards, visit the ASTM website, [www.astm.org](http://www.astm.org), or contact ASTM Customer Service at [service@astm.org](mailto:service@astm.org). For *Annual Book of ASTM Standards* volume information, refer to the standard's Document Summary page on the ASTM website.

<sup>3</sup> Available from American National Standards Institute (ANSI), 25 W. 43rd St., 4th Floor, New York, NY 10036.

3.1.2 *backstop*—an object intended to stop a paintball.

3.1.3 *barrel*—that portion of a paintball marker through which the paintball is discharged.

3.1.4 *barrel blocking device*—a muzzle blocking safety device which, when properly installed, reduces the likelihood of an intact paintball discharging from the marker or leaving the confines of the barrel blocking device. The device is often referred to as a barrel plug or barrel bag.

3.1.5 *burst mode marker*—a burst mode marker may discharge two or more times per trigger cycle or may discharge two or more times with the pull and release of the trigger.

3.1.6 *caliber*—the term used to refer to the size of a paintball projectile. Related to the measurement of the diameter of the paintball as described in Specification F1979.

3.1.7 *cautionary statement*—the warning outlined in Section 8 of this standard, which is to be placed on paintball markers, packaging and literature.

3.1.8 *de-gassed, n*—the state of the marker in which the propellant source and any internal propellant has been removed from the marker.

3.1.9 *disabling device*—a device which, when activated, disables a part of the paintball marker, usually the trigger, to prevent unintentional discharges and must be released to allow the marker to be discharged by the movement of the trigger. The device is sometimes referred to as the “safety,” “safety button,” or “safety lever.” An electronic on/off switch is considered a disabling device when placing it in the “off” position renders the marker inoperable.

3.1.10 *discharge mode*—a mode that controls the number of paintballs discharged per trigger cycle.

3.1.11 *enhanced trigger mode marker*—a paintball marker that at some point discharges more than one paintball per trigger cycle. This includes markers that “store” the number of trigger pulls and discharge more than one paintball at some point.

3.1.12 *feed mechanism*—a mechanism that stores, transports and facilitates the loading of paintballs. It may be gravity, mechanically or air assisted or automatic in its actions.

3.1.13 *fully-automatic mode marker*—a marker that discharges when the triggering device is actuated and continues to discharge until the trigger returns to its reset or recycle position.

3.1.14 *hopper*—a device used with a paintball marker to store paintballs.

3.1.15 *impact tester*—device used to test for accidental discharges of paintball marker. See Fig. 1.

3.1.16 *modified fully automatic mode 1 marker*—a semi-automatic mode marker which, after the trigger is pulled at least three times within 1 s, is able to function in a fully automatic mode with a firing rate not to exceed 15 shots per second until the trigger is released.

3.1.17 *modified burst mode 2 marker*—a semi-automatic mode marker which, after the trigger is pulled at least three times within 1 s, is able to cycle more than one time per trigger pull with a firing rate not to exceed 15 shots per second.

3.1.18 *paintball*—a spherical ball, comprised of a shell and a fill, designed to be expelled from a paintball marker, as defined in Specification F1979.

3.1.19 *paintball marker*—a device specifically designed to discharge paintballs. The device is sometimes referred to as a paintball gun.

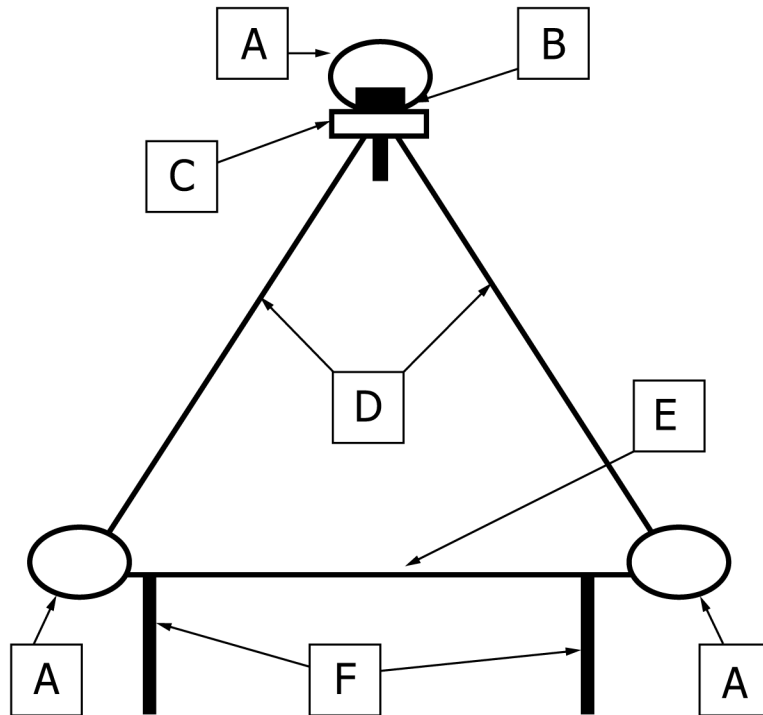

- A. Yoke
- B. Pivot Bolt
- C. Swivel
- D. 91.29 cm (36 in.) Strap or Rope
- E. 60.86 cm (24 in.) aluminum bar with 1.27 cm (0.5 in.) diameter or 1.9 cm (0.75 in.) copper tube
- F. Hook and loop strap able to suspend marker parallel to and 15.21 cm (6 in.) below E

FIG. 1 Marker Suspension Sling

3.1.20 *pump mode marker*—a marker that requires the operator to manually cock or engage the sear of the marker before each shot by a means of a pump, bolt, lever, cocking handle or similar device.

3.1.21 *range*—the maximum distance to which an object may be propelled, whether limited by energy or an obstacle.

3.1.22 *response trigger*—a semi-automatic paintball marker in which after firing the trigger is assisted back to the reset position.

3.1.23 *sear*—the catch that holds the mechanism in the ready-to-discharge position until released by the user, usually through trigger movement.

3.1.24 *selector switch*—a switch (either internal or external) regardless of method of activation that is designed to allow the consumer to change the marker’s discharge mode.

3.1.25 *semi-automatic mode marker*—a semi-automatic marker discharges one time with each trigger cycle. Markers that “store” the number of trigger pulls and discharge more than one paintball at some point do not meet this definition. Markers that operate in any other discharge mode(s) do not meet this definition.

3.1.26 *standard ambient temperature and pressure (SATP)*—used to describe a substance at the pressure of 1 bar (1.01325 atmospheres, 750 mm Hg, 14.5 psi, 100 kPa) and a temperature of 25°C (77°F).

3.1.27 *target*—the object at which the paintball is discharged.

3.1.28 *trigger*—a device operated by the user to discharge a marker.

3.1.29 *trigger, adjustable*—a trigger mechanism in which the trigger pull is adjustable.

3.1.30 *trigger cycle*—the movement of the trigger through discharge and returning to a reset or recycle position.

3.1.31 *trigger, double-action*—a trigger mechanism in which a single continuous action of the trigger moves the hammer to the discharging position and then releases it to discharge the paintball.

3.1.32 *trigger guard*—a rigid, firmly attached component. It must totally enclose the trigger area and be wider than the trigger. There can be no more than 38 mm (1.5 in.) of space from any point on the face of the trigger to the trigger guard, and no more than 13 mm (0.5 in.) from the lowest point of the trigger to the trigger guard. All measurements under this rule are to be taken after excluding any removable attachments to the trigger.

3.1.33 *trigger pull*—the force required to move the trigger from its start or recycle/reset position to a position that discharges the marker.

3.1.34 *velocity adjuster*—a device designed to establish the velocity at which a paintball is discharged.

#### **4. Significance and Use**

4.1 This specification establishes performance requirements and test methods for paintball markers.

4.2 This specification identifies the minimum warnings and instructions that are to be provided in literature, on labels, on packaging and on the marker itself.

#### **5. Conformance**

5.1 Paintball markers shall not, either by label or other means, indicate conformance with this specification unless, at the time of manufacture, they conform with all applicable requirements contained herein.

#### **6. General Requirements**

6.1 *Literature*—Literature shall be provided with each paintball marker and shall include, as applicable, the instructions, cautionary statements and safety tips specified in Section 8.

6.2 *Packaging:*

6.2.1 Packaging shall be labeled in a prominent and conspicuous manner in accordance with the provisions of 8.5.

6.2.2 All paintball markers that include a barrel must be packaged with a barrel blocking device.

6.3 *Finish*—The exposed edges of all paintball markers shall be smooth and free of sharp edges and burrs. The exposed surface of all wood parts shall be smooth and free of splinters.

6.4 *Shipping:*

6.4.1 Each paintball marker shall be shipped in an unloaded and degassed condition.

6.4.2 All paintball markers must shoot at a velocity under 91.44 m/s (300 ft/s) at the time of shipment at SATP.

6.5 *Design:*

6.5.1 All paintball markers with an exposed trigger shall have a trigger guard.

6.5.2 All paintball markers intended to be used with refillable cylinders shall be able to withstand input pressure of three thousand pounds per square inch 207 bar (3000 psi) without catastrophic failure. Leaking in a manner which would not cause injury to the operator shall not constitute failure.

6.5.3 A marker's performance may not be enhanced, including but not limited to increasing the markers' velocity, without the use of tools or the need for disassembly. In the event that a marker requires an internal switch, jumper or other device to be set prior to using outside adjustments, it will be considered to meet this requirement provided that tools or disassembly are required to access the switch, jumper or similar device.

6.5.4 All paintball markers shall only operate in pump, semi-automatic, modified fully automatic mode 1, or modified burst mode 2, response trigger, or a combination thereof, as defined in this standard.

## 7. Performance Requirements

7.1 *Marker Function*—The cocking or pumping mechanism of a paintball marker shall not cause a marker to discharge unintentionally while a marker is being cocked in accordance with the manufacturer's instructions. This does not limit the use of "auto-triggers." Markers shall be pump, semi-automatic, modified fully automatic mode 1, or modified burst mode 2, response trigger, or a combination thereof, as defined in this standard.

7.2 *Gas Propellant Source Retention*—Markers shall be designed so that a gas propellant source does not inadvertently eject from the marker during use or otherwise.

7.3 *Disabling Device*—Disabling devices shall be provided on all paintball markers and all such devices can be ended whether or not the marker is cocked. All such devices shall be clearly marked to indicate the "safe" and "fire" or "on" and "off" positions in accordance with 8.6.4. All such devices shall be capable of preventing the markers from being discharged when a weight of 13.6 kg (30 lb) is applied to the trigger. Tests shall be conducted in accordance with 8.3.

7.4 *Accidental Discharge*—Markers should not accidentally discharge when exposed to a moderate jolt in accordance with 8.3.

## 8. Test Methods

8.1 No precision statement on any of the following test methods is available at this time.

### 8.2 *Disabling Device Test:*

8.2.1 *Significance*—This method determines if the disabling device will withstand a 13.6 kg (30 lb) applied weight without failure, causing the marker to discharge.

8.2.2 *Apparatus*—A trigger weight system having a  $13.6 \pm 0.02$  kg ( $30 \pm 0.05$  lb) weight. Arrange the weight system so that the weights can be picked up by the trigger of the marker with the marker in a vertical position, muzzle up. (A spring gage, capable of measuring the trigger force, can be used instead of weight system.)

8.2.3 *Test Specimen*—The test specimen shall consist of a new paintball marker, selected in accordance with the manufacturer's usual quality assurance practices.

### 8.2.4 *Procedure:*

8.2.4.1 Conduct the test at SATP.

8.2.4.2 Conduct all tests without paintballs in the marker.

8.2.4.3 Place disabling device in "safe" position or the electronic switch in the "off" position.

8.2.4.4 Apply a 13.6 kg (30 lb) load at the center point of the trigger for 30 s with the load applied to the center of the face of the trigger and remove the load.

8.2.4.5 Put disabling device in the "fire" position or the electronic switch in the "on" position. The marker must not discharge as the safety is disengaged.

8.2.4.6 Test the marker for proper trigger and disabling device action.

8.2.4.7 The marker passes the test if it withstands the load applied without causing the marker to discharge during the application of the load and does not discharge upon the disengagement of the disabling device, and the disabling device and trigger function properly after testing.

### 8.3 *Accidental Discharge Test:*

8.3.1 *Significance*—Paintball markers should not discharge when jarred or jolted in a moderate manner while their disabling device is disengaged.

8.3.2 *Test Specimen*—The test specimen shall consist of a new paintball marker, selected in accordance with the manufacturer's usual quality assurance practices.

#### 8.3.3 *Procedure:*

8.3.3.1 Conduct the test at SATP.

8.3.3.2 Attach a properly charged propellant source in accordance with the manufacturer's instructions. Test discharge the marker.

8.3.3.3 Leave the marker in the ready to discharge condition.

8.3.3.4 Suspend marker using a sling (see Fig. 1).

8.3.3.5 Place the cocked impact tester (see Fig. 2) against the side of the marker centered on the grip frame directly behind the center point of the trigger with the impact tester firmly affixed to an immobile surface.

8.3.3.6 Release the impact tester and observe if the marker discharges.

8.3.3.7 Repeat by impacting the marker on the following axis:

- (1) 180 degrees to the first impact.
- (2) The front of the barrel aligned with the barrel's axis.
- (3) The rearmost point of the marker aligned with the barrel's axis.

8.3.3.8 The marker fails if it discharges on any impact.

### 8.4 *Barrel Blocking Device Requirement:*

8.4.1 *Significance*—All paintball markers which include a barrel must be packaged with a barrel blocking device.

8.4.2 *Test Specimen*—The test specimen shall consist of a new paintball marker, packaged in the manufacturer's original packaging.

8.4.3 *Procedure*—Open packaging and inspect for the presence of a barrel blocking device. Any package not containing a barrel blocking device fails this requirement.

8.5 *Product Packaging*—The packaging of all paintball markers shall contain a cautionary statement. The statement shall be placed prominently on the package and set distinctively apart from other wording or designs.

8.5.1 Prominence of the statement shall be achieved by placement within the borders of a rectangle and by use of a suitable contrasting background. The statement may be a combination of upper and lower case letters of a size not less than 8-point type. The letters in the signal word shall be at least 50 % larger than the letters in other words in the cautionary statement. The signal word shall be in sans serif letters in upper case only and preceded by a safety alert symbol. It is composed of an equilateral triangle surrounding an exclamation point. The base of the safety alert symbol shall be on the same horizontal line as the base of the letters of the signal word. The height of the safety alert symbol shall equal or exceed the signal word height. The signal word shall be in black letters on an orange background. The solid triangle of the safety alert symbol shall be black and the exclamation point portion orange. The cautionary statement shall have either black lettering on a white background or white lettering on a black background. When special circumstances limit the use of warning in two colors, the colors assigned to the signal word background

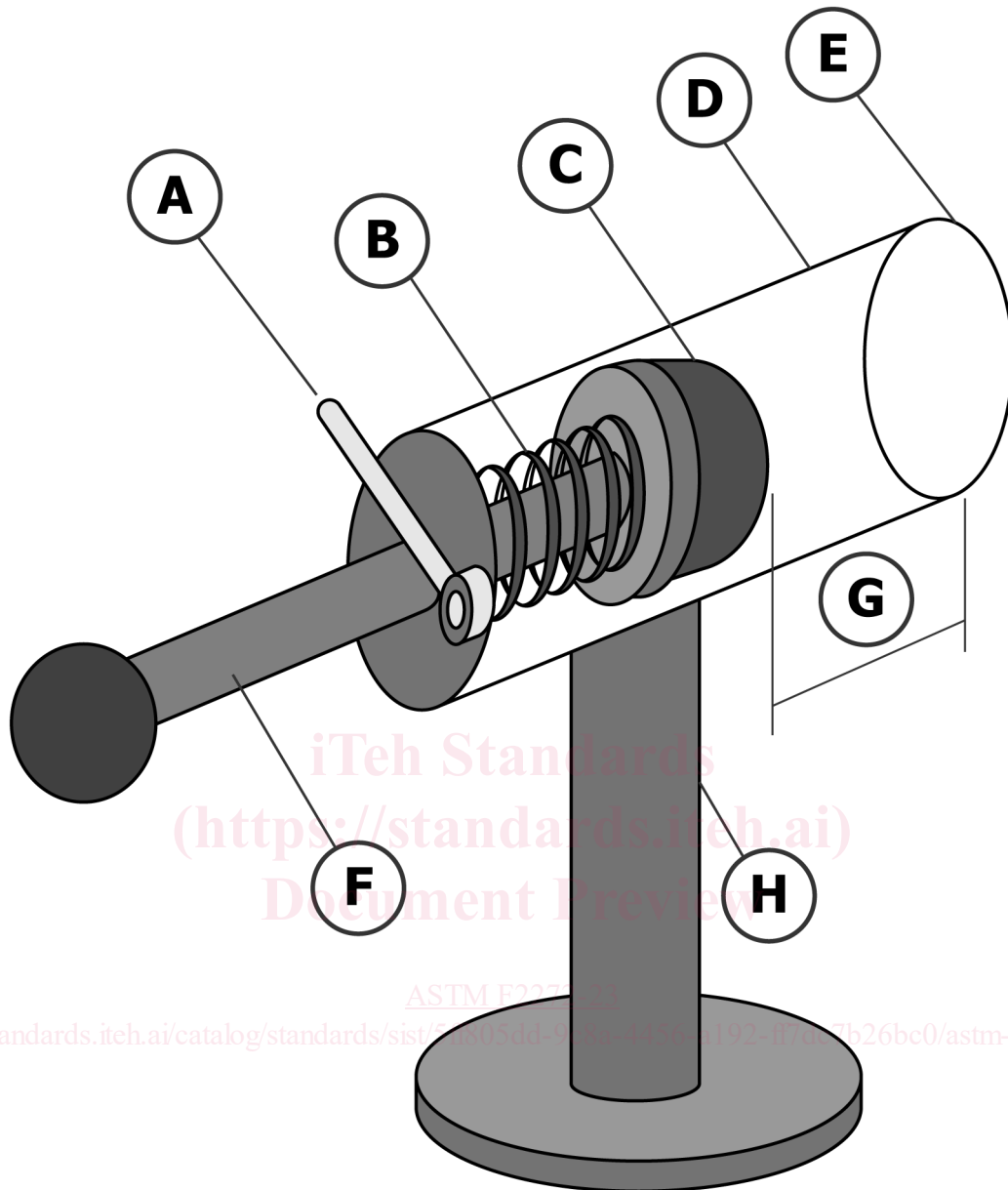

- A. Release Latch
- B. Compression Spring (spring rate 1.145 kg/cm or 16.28 lb/in.) with free length of  $22.86 \pm 0.381$  cm ( $9.0 \pm 0.150$  in.). The compressed length of the spring in the cocked position shall be  $8.89 \pm 0.318$  cm ( $3.5 \pm 0.125$  in.).
- C. Impact Ball (new pressurized tennis ball with regular felt, total mass of moving parts is 1.13 kg or 2½ lb)
- D. Plastic tube with 7.62 cm (3 in.) internal diameter
- E. Face placed against marker
- F. Cocking arm
- G. Stroke of 15.21 cm (6 in.)
- H. Secured support base

**FIG. 2 Marker Impact Simulation Tester**

may also be used for the cautionary statement letters, provided that they contrast with the background color of the product. When special circumstances preclude the use of safety colors on base materials such as wood, cardboard, metal, plastic, etc., the marking used should (when feasible) contrast with the background color of the base material.

8.5.2 The packaging of all paintballs markers shall be prominently and durably marked to convey the following cautionary statement:

8.5.2.1 A signal word such as “WARNING,” “DANGER” or “CAUTION.”