



Designation: D8490 – 23a

# Standard Test Method for Determining the Pore Size Characteristics of Geotextiles Using an Optical Method<sup>1</sup>

This standard is issued under the fixed designation D8490; the number immediately following the designation indicates the year of original adoption or, in the case of revision, the year of last revision. A number in parentheses indicates the year of last reapproval. A superscript epsilon ( $\epsilon$ ) indicates an editorial change since the last revision or reapproval.

## 1. Scope

1.1 This test method covers the determination of the pore size characteristics of geotextiles using an optical method and image analysis.

1.2 This method has been developed for determination of the Image Opening Size (IOS) of knitted geotextiles by image analysis. Other properties may be obtained based on the pore size distribution.

1.3 The applicability of this test method must be assessed on a product-by-product basis, as it requires light to pass through its thickness to provide a useful observation. As a general rule, the tested product must be thin. Example of products which cannot be tested using this test method is thick needle-punched nonwoven and woven with a complex three-dimensional structure.

1.4 This test method shows values in both SI units and inch-pound units. SI units is the technically correct name for the system of metric units known as the International System of Units. Inch-pound units is the technically correct name for the customary units used in the United States. The values in inch-pound units are provided for information only.

1.5 *This standard does not purport to address all of the safety concerns, if any, associated with its use. It is the responsibility of the user of this standard to establish appropriate safety, health, and environmental practices and determine the applicability of regulatory limitations prior to use.*

1.6 *This international standard was developed in accordance with internationally recognized principles on standardization established in the Decision on Principles for the Development of International Standards, Guides and Recommendations issued by the World Trade Organization Technical Barriers to Trade (TBT) Committee.*

<sup>1</sup> This test method is under the jurisdiction of ASTM Committee D35 on Geosynthetics and is the direct responsibility of Subcommittee D35.03 on Permeability and Filtration.

Current edition approved June 15, 2023. Published June 2023. Originally approved in 2023. Last previous edition approved in 2023 as D8490 – 23. DOI: 10.1520/D8490-23A.

## 2. Referenced Documents

### 2.1 ASTM Standards:<sup>2</sup>

- D123 Terminology Relating to Textiles
- D4354 Practice for Sampling of Geosynthetics and Rolled Erosion Control Products (RECPs) for Testing
- D4439 Terminology for Geosynthetics
- D4751 Test Methods for Determining Apparent Opening Size of a Geotextile
- E11 Specification for Woven Wire Test Sieve Cloth and Test Sieves

### 2.2 Other Standards:

- ISO 12956 Geotextiles and Geotextile-Related Products—Determination of the Characteristic Opening Size<sup>3</sup>
- CGSB 148.1 No. 10 Methods of Testing Geosynthetics Geotextiles—Filtration Opening Size<sup>4</sup>

## 3. Terminology

3.1 *Definitions*—For definitions of other textile terms used in this test method, refer to Terminology D123. For definitions of other terms relating to geosynthetics used in this test method, refer to Terminology D4439.

### 3.2 Definitions of Terms Specific to This Standard:

3.2.1 *circular knit, n*—a structure produced by interlooping one or more ends of yarn or comparable material in a continuously circular orientation around the fabric.

3.2.2 *ellipse diameter, n*—measured from the “best-fit” ellipse fitting inside a given opening.

3.2.2.1 *Discussion*—The minimum and maximum ellipse diameter are the smallest and largest diameter of the ellipse fitting the inside of an opening when varying the axis of the ellipse in the plane of observation (Fig. 1).

3.2.3 *Feret diameter, n*—distance between two parallel lines tangent to the silhouette of the opening.

<sup>2</sup> For referenced ASTM standards, visit the ASTM website, www.astm.org, or contact ASTM Customer Service at service@astm.org. For *Annual Book of ASTM Standards* volume information, refer to the standard’s Document Summary page on the ASTM website.

<sup>3</sup> Available from American National Standards Institute (ANSI), 25 W. 43rd St., 4th Floor, New York, NY 10036, http://www.ansi.org.

<sup>4</sup> Available from Canadian General Standards Board (CGSB), 11 Laurier St., Phase III, Place du Portage, Gatineau, Quebec K1A 0S5, Canada, http://www.tpsgc-pwgsc.gc.ca/ongc-cgsb.

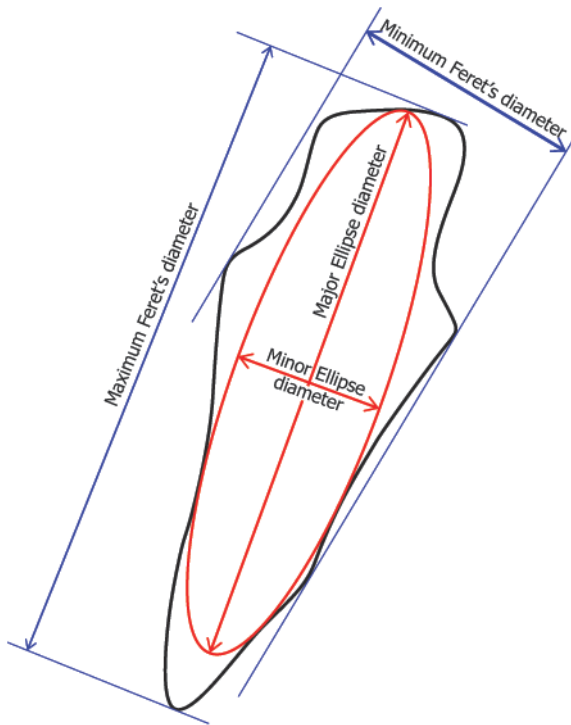

**FIG. 1** Feret's and Ellipse Diameters

calibrated beads through specimens of the geotextile being evaluated. However, Test Method **D4751** includes many risks of errors due to static electricity, precision of the glass beads, among other issues.<sup>5</sup> This risk of error is even higher with knitted geotextiles which exhibit a very low tensile modulus. This test method is proposed as an alternate to Test Method **D4751** using a nondestructive technique, where the stress conditions are controlled without manipulation of the specimen.

5.2 This test method has been found to provide representative results for products exhibiting a planar structure, such as two-dimensional knits.

5.3 In case of a dispute arising from differences in reported test results when using ASTM **D4751** Method A and this method, ASTM **D4751** Method A shall be considered the referee method. However, data obtained using ASTM **D4751** Method A should be reviewed considering the high risk of human error associated with the control of the stress condition of the geotextile.

5.4 Equivalency with the other pore opening size determined using other standards (for example, ISO 12956 and CGSB 148.1 No. 10) can also be considered using adequate correlations with test results obtained with these standards.

## 6. Apparatus

6.1 *Stretching Structure*—When testing circular knit geotextiles, a structure able to control the circumference of the specimen and to uniformly apply a tensile stress in the machine direction must be used. An example of such a structure is presented in Fig. 2. This structure is not necessary when testing planar geotextiles where no stress needs to be applied.

6.1.1 The structure permits clamping of the specimen on the upper end.

6.1.2 A free clamp is used on the bottom to apply a load using a dead weight.

6.1.3 Two vertical columns are installed to control the circumference of the specimen. The distance between these columns must be adjustable and should be approximately equal distance from the centerline of the image viewing area.

6.1.4 It must be possible to stop the geotextile from creeping after some time, using a secondary clamp fixed on the frame itself.

6.1.5 The edges must be rounded to avoid accidental tear of the specimen.

6.2 *Light Source*, attached to the stretching structure, offering a diffused light on a surface larger than the image captured.

NOTE 2—The NERLITE<sup>6</sup> BL 50×200 LED Backlight was found to be satisfactory.

6.3 *Image Acquisition Device*, positioned with its axis perpendicular to the plane of the geotextile. The sensor and

<sup>5</sup> Blond, E., Veermersch, O., Diederich, R., "A Comprehensive Analysis of the Measurement Techniques Used to Determine Geotextile Opening Size: AOS, FOS, O90, and Bubble Point," *Proceedings of Geosynthetics 2015*, Portland, OR, February 15–18, 2015.

<sup>6</sup> NERLITE is a registered trademark of Microscan Systems, Inc., 700 SW 39th St. Renton, WA 98057.

3.2.3.1 *Discussion*—The minimum and maximum Feret diameter are the smallest and largest distance between two parallel lines tangent to the opening's silhouette when varying the angle of these lines in the plane of observation (Fig. 1).

3.2.4 *image opening size (IOS), n*—for a knitted geotextile, a property that indicates the size of a soil particle which can be effectively expected to pass through the geotextile.

3.2.5 *opening, n*—surface with an irregular shape, through which the light can pass.

## 4. Summary of Test Method

4.1 For circular knit geotextiles, a specimen is placed in a frame where its circumference will be controlled to reflect the outside diameter of the pipe on which it will be installed. A stress is applied in the longitudinal direction to normalize the condition under which the product will be observed.

4.2 An image of the surface of the geotextile is captured. The image is processed to determine relevant properties of each opening, such as the minimum Feret diameter and the minimum ellipse diameter. A pore size distribution and a significant pore size defined as the image opening size, IOS, are defined based on these observations.

NOTE 1—The minimum size of the image function should be selected considering the size of the openings of the product to be tested. For knitted geotextile with openings up to 0.5 mm, an image 7.0 mm by 7.0 mm permitting the capture of 50 openings or more has been found satisfactory.

4.3 An equivalent Apparent Opening Size can be estimated based on the IOS.

## 5. Significance and Use

5.1 The significant opening size of geotextiles is usually determined using Test Method **D4751**, which involves sieving

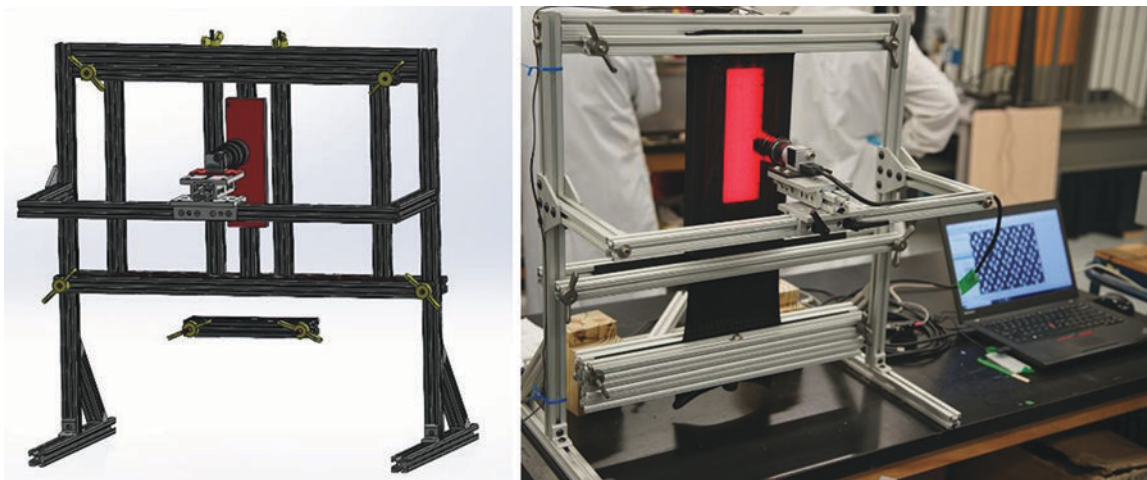

FIG. 2 Stretching Structure

optic used must permit the capture of an image at least 7 mm by 7 mm, with a resolution of at least 250 pixels per millimeter length captured on the test specimen for products with a mean opening size of 150  $\mu\text{m}$  or more. Other image sizes may be considered for smaller or bigger opening sizes.

NOTE 3—The criteria of 250 pixels per millimeter length is equivalent to one pixel for 4  $\mu\text{m}$ . However, this measurement differs from the precision of the opening size measurement considering the use of image analysis technique.

NOTE 4—The sensor Basler ace acA3800-14m 10Mp equipped with a Kowa 2/3" 10Mp LM35mm/F2.0 C-Mount lens was found to be satisfactory.

6.4 *Image Processing Software*, able to:

6.4.1 Process the image to define edges of the openings being measured and exclude stray yarns.

6.4.2 Determine the desirable property of each opening, such as the minimum Feret diameter, minimum ellipse diameter, area, perimeter, and/or another property of interest.

6.4.3 Export the results for further processing.

NOTE 5—Image-J software with the Fiji extension was found to be satisfactory. It is available for free at <https://imagej.net/software/fiji/downloads>.

6.5 *Image Analysis Routine*.

NOTE 6—The routine provided in Annex A1 was found to be satisfactory for the Image-J software with the Fiji extension.

6.6 *Calibrated Micrometric Ruler*, 1.0 mm long or greater, graduated to 0.01 mm or less. The calibrated ruler should be on a glass with a thickness of  $1.0 \pm 0.1$  mm.

## 7. Sampling and Test Specimens

7.1 *Sampling*:

7.1.1 For manufacturer's quality control (MQC) testing, divide rolls of the product into lots and take the lot sample as directed in Practice D4354, Section 7, Procedure B—Sampling for Manufacturer's Quality Assurance Testing.

7.1.2 For specification conformance testing, sample as directed in Practice D4354, Section 8, Procedure C—Sampling for Purchaser's Specification Conformance Testing.

7.2 *Test Specimens, Circular Knit Geotextiles*:

7.2.1 Cut at least three (3) specimens of the circular knit geotextile with a minimum length of 500 mm. This length may have to be longer for products intended to be installed on pipes with a nominal diameter larger than 150 mm (6 in.).

7.2.2 Lay tubular fabric flat on a solid surface and make sure edges of fabric are parallel in the longitudinal direction. Make sure there are no wrinkles or torque in the fabric. Draw a line perpendicular to the longitudinal edges and make sure the line is drawn across the width of fabric touching both parallel edges. Draw a second line at the approximate location of the lower clamp (for example, 300 to 500 mm depending on the height of the structure and how much the fabric will stretch) using the same technique as above.

7.2.3 Make a cut  $50 \pm 10$  mm in the machine direction on both sides of the same end of the test specimen (Fig. 3).

7.3 *Test Specimens, Planar Geotextiles*:

7.3.1 Cut specimens with a size significantly larger than the observation area, to be able to hold it in place and control the distance between the specimen and the image acquisition device. The specimen should entirely cover the light source.

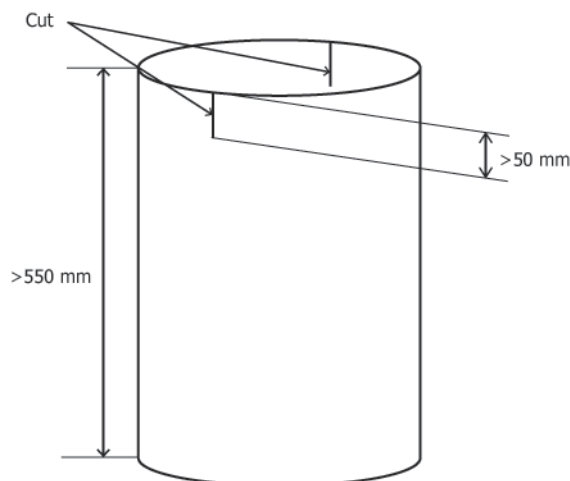

FIG. 3 Position of the Cuts

## 8. Preparation of Apparatus

8.1 When testing circular knit geotextiles, the stretching structure must be used. It must stand on a stable table or counter top, exempt of vibrations, allowing enough space for the lower clamp to hang without touching a surface.

8.2 When testing planar geotextiles where no stress needs to be applied on the specimen, the image acquisition device may be used in any direction as long as perpendicularity with the test specimen and working distance is controlled.

8.3 Optics of the image acquisition device must be clean, without dust or mold.

## 9. Calibration and Standardization

9.1 A calibration must be performed each time there is a change of distance between the plane in focus (that is, the plane of the sample) and the optical acquisition device.

9.2 Install the micrometric ruler with the graduation facing the image acquisition device in place of the test specimen, that is, by taping it on the light source. Adjust the focus and proceed with the measurement of the number of pixels corresponding to a 1 mm length of the ruler, using the image acquisition software calibration feature.

9.3 Turn the ruler around so the graduations face the light source, that is, are ~1.0 mm farther away from the image acquisition device. Adjust the focus and proceed with the measurement of the number of pixels corresponding to a 1 mm length of the ruler, using the image acquisition software calibration feature.

9.4 Average the measurements made in 9.1 and 9.2 to define the number of pixels per millimeter on the acquired image.

## 10. Conditioning

10.1 The samples must be conditioned to  $21 \pm 2^\circ\text{C}$  ( $70 \pm 4^\circ\text{F}$ ) for at least 24 h before proceeding with the optical measurement. For manufacturing quality control, this duration can be reduced. Should differences arise between results obtained on non-conditioned versus conditioned samples, the conditioned samples are to be considered the referee.

## 11. Stretching (for Circular Knit Geotextiles)

11.1 To obtain a laboratory sample for MQC testing of the circular knit geotextile, follow the procedure below:

11.1.1 Adjust the distance between the two vertical columns so the circumference of the stretched specimen will be equal to the circumference of the outside of the pipe on which the geotextile is to be applied.

11.1.1.1 Annex A2 presents typical outside diameters of corrugated HDPE drainage pipes. This information could be used for determination of the distance to be used between the two vertical columns, should the pipe diameter be unknown.

11.1.2 Install the circular knit geotextile sample between the two vertical columns, with the two cuts positioned equidistant to the left and the right sides of the vertical plane where measurements will be made. Pull the specimen through the front and the back clamps as described in Fig. 4. Use of tape on the edges (for example, duct tape or masking tape) may be useful to prevent curling of the edges and facilitate installation.

11.1.3 Tighten the clamp, making sure the lower side of the clamp sits on the first line perpendicular to the direction of the tube as described in 7.2.2, that is, with as little deformations in MD as possible.

11.1.4 Install the clamp on the bottom side of the specimen and make sure the top side of the clamp sits on the second perpendicular line drawn as described in 7.2.2 which is 500 mm from the first line. Use a clamp exhibiting the weight defined in Table 1. Use the same caution for alignment of the clamp as for the upper clamp. When installing the specimen in the clamp, it must rest on a support to avoid tensioning the specimen.

11.1.5 Remove the support of the clamp to apply the stress on the specimen.

11.1.6 After  $2 \text{ min} \pm 5 \text{ s}$ , tighten the secondary clamp to stop any further creep of the specimen.

## 12. Image Acquisition and Processing

12.1 Acquire an image using a light intensity and camera settings to obtain an image with a non-saturated background, in focus on the entire thickness of the test specimen. A non-saturated background can be confirmed with the absence of a

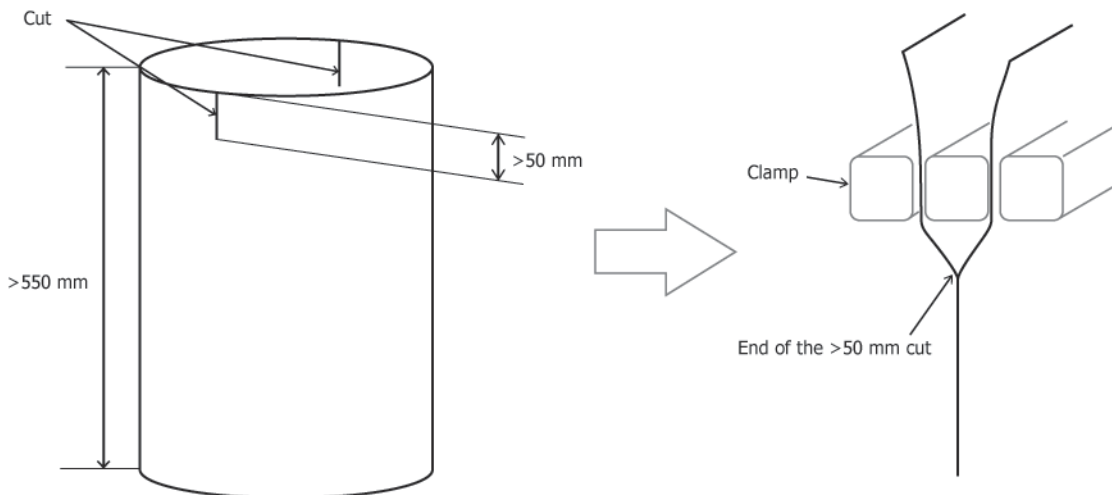

FIG. 4 Positioning of the Specimen in the Clamps



**TABLE 1 Weight to Be Applied on the Test Specimen**

Nominal Diameter	Weight to Hang
~50 mm to ~150 mm (~2 in. to ~6 in.)	1.13 kg (2.5 lb)
~200 mm to 300 mm (8 in. to 12 in.)	2.25 kg (5 lb)
>300 mm (>12 in.)	To be agreed between parties

large quantity of white pixels on the histogram of the acquired image, before processing.

NOTE 7—Examples of images immediately after acquisition are provided in [Appendix X1](#).

12.2 Process the image to differentiate the objects, that is, the fibers of yarns, and background, that is, the openings on the image.

12.2.1 The routine provided in [Annex A1](#) can be used when using the Image-J software with the Fiji plugin.

12.2.2 The method used to differentiate the background, that is, the opening, and the solid objects, that is, the fibers of yarns, must be defined considering the features of the tested product. For knitted geotextiles manufactured with white or black yarns, the auto threshold method ‘IJ\_IsoData’ has been found to deliver results with a good correlation with the opening size measured with glass beads. This procedure divides the image into object and background by taking an initial threshold, then the averages of the pixels at or below the threshold and pixels above are computed. The averages of those two values are computed, the threshold is incremented, and the process is repeated until the threshold is larger than the composite average. That is:

$$\text{threshold} = (\text{average background} + \text{average objects}) / 2 \quad (1)$$

NOTE 8—refer to <https://imagej.net/plugins/auto-threshold> for further information on the threshold calculation method.

12.3 Save the image and the results obtained for further calculation. These results should include at least the minimum Feret diameter and minimum ellipse diameter for each opening.

### 13. Calculation or Interpretation of Results

13.1 Verify the overall consistency between the image after processing, and the original image.

13.2 Determine the image opening size (IOS) as the median value of the minimum Feret diameter for each image, that is, each test specimen.

NOTE 9—The median value is the value for which there is an equal number of measurements greater and smaller than the value.

NOTE 10—Other properties such as the ellipse diameter, area, or perimeter may be determined using the same approach.

13.3 Calculate the average and coefficient of variation of the three measurements of IOS made in [13.2](#).

13.4 When required, report the distribution of openings by counting the number of times a minimum Feret diameter meets the dimensions of a class of openings as defined in Specification [E11](#), for each class.

13.5 When required, define the equivalent apparent opening size using:

$$\text{AOS} = \text{IOS} \times C \quad (2)$$

where:

AOS = opening size, comparable to the property determined using Test Method [D4751](#) Method A, and

C = constant determined experimentally.

NOTE 11—Determination of the value of *C* requires side-by-side testing of candidate products using the optical method, and the original method, for example, AOS per Test Method [D4751](#). Using the median value of the minimum Feret diameter was found to be satisfactory for a range of planar knitted geotextile manufactured with white or black yarns, but another optical property may be found to be more suitable for other products, for example, ellipse minimum diameter, or a value of O50, O90, or O95 instead of the median diameter.

### 14. Report

14.1 Report that the specimens were tested as directed in Test Method [D8490](#).

14.2 Identification of the tested sample including product designation, lot number and manufacturing date, and/or any information available to permit traceability of the sample.

14.3 Report the settings used for the image acquisition:

14.3.1 Sensor sensitivity / amplification setting;

14.3.2 Speed;

14.3.3 Aperture opening; and

14.3.4 Light source and intensity setting.

14.4 Report the image properties:

14.4.1 Number of pixels per millimeter determined in [9.3](#); and

14.4.2 Threshold value.

14.5 Report the following information:

14.5.1 Image opening size as determined in [13.2](#) and [13.3](#): individual measurements, average, and coefficient of variation;

14.5.2 When requested, a table summarizing the distribution of opening sizes as defined in [13.4](#); and

14.5.3 When requested, the value of apparent opening size (AOS) as determined in [13.5](#).

14.6 Any deviation from the described test method.

### 15. Precision and Bias

15.1 The precision and bias for this test method are being evaluated.

### 16. Keywords

16.1 AOS; filter; filtration; geotextile; image analysis; image opening size; IOS; opening size; pore size distribution