



Designation: B648 – 23

Standard Test Method for Indentation Hardness of Aluminum Alloys by Means of a Barcol Impressor¹

This standard is issued under the fixed designation B648; the number immediately following the designation indicates the year of original adoption or, in the case of revision, the year of last revision. A number in parentheses indicates the year of last reapproval. A superscript epsilon (ϵ) indicates an editorial change since the last revision or reapproval.

1. Scope

1.1 This test method covers the determination of indentation hardness of aluminum alloys using a Barcol Impressor.

1.2 The values stated in SI units are to be regarded as standard. The values given in parentheses after SI units are provided for information only and are not considered standard.

1.2.1 Some Barcol Impressors are for use on plastics and are not included in this test method and should not be used for aluminum alloys.

1.3 *This standard does not purport to address all of the safety concerns, if any, associated with its use. It is the responsibility of the user of this standard to establish appropriate safety, health, and environmental practices and determine the applicability of regulatory limitations prior to use.*

1.4 *This international standard was developed in accordance with internationally recognized principles on standardization established in the Decision on Principles for the Development of International Standards, Guides and Recommendations issued by the World Trade Organization Technical Barriers to Trade (TBT) Committee.*

2. Referenced Documents

2.1 *ASTM Standards:*²

E6 Terminology Relating to Methods of Mechanical Testing

E10 Test Method for Brinell Hardness of Metallic Materials

E18 Test Methods for Rockwell Hardness of Metallic Materials

E177 Practice for Use of the Terms Precision and Bias in ASTM Test Methods

E691 Practice for Conducting an Interlaboratory Study to Determine the Precision of a Test Method

¹ This test method is under the jurisdiction of ASTM Committee B07 on Light Metals and Alloys and is the direct responsibility of Subcommittee B07.05 on Testing.

Current edition approved June 1, 2023. Published June 2023. Originally approved in 1978. Last previous edition approved in 2015 as B648 – 10 (2015) ^{ϵ 1}. DOI: 10.1520/B0648-23.

² For referenced ASTM standards, visit the ASTM website, www.astm.org, or contact ASTM Customer Service at service@astm.org. For *Annual Book of ASTM Standards* volume information, refer to the standard's Document Summary page on the ASTM website.

3. Terminology

3.1 *Definitions*—The definitions of terms relating to hardness testing appearing in Terminology E6 shall be considered as applying to the terms used in this test method.

4. Significance and Use

4.1 The Barcol Impressor is portable and therefore useful for in situ determination of the hardness of fabricated parts and individual test specimens for production control purposes.

4.2 This test method should be used only as cited in applicable material specifications.

5. Apparatus

5.1 *Barcol Impressor*—See Fig. 1.

5.2 *Indenter*—The indenter shall consist of a hardened steel truncated cone having an angle of 26° with a flat tip 0.157 mm (0.0062 in.) in diameter. It shall fit into a hollow spindle and be held down by a spring-loaded plunger. See Fig. 1.

5.3 *Indicating Device*—The indicating dial shall have 100 divisions, each representing a depth of 0.0076 mm (0.00030 in.) penetration. The higher the reading, the harder the material.

6. Test Parts or Specimen

6.1 The testing area shall be smooth, clean, and free of mechanical damage. The surface may be lightly polished to eliminate scratches or die lines. It shall be such that it can be essentially perpendicular to the indenter during the test.

NOTE 1—The effect of curvature of the test specimen on the Barcol Impressor readings is presented in Appendix X1, Fig. X1.1.

6.2 *Dimensions*—Test parts or specimens shall be at least 1.5 mm ($1/16$ in.) thick and large enough to ensure a minimum distance of 3 mm ($1/8$ in.) in any direction from the indenter point to the edge.

7. Calibration

7.1 With the plunger upper guide backed out until it just engages the spring, place the impressor on a glass surface and press down until the penetrator point is forced all the way back into the lower plunger guide. The indicator should then read

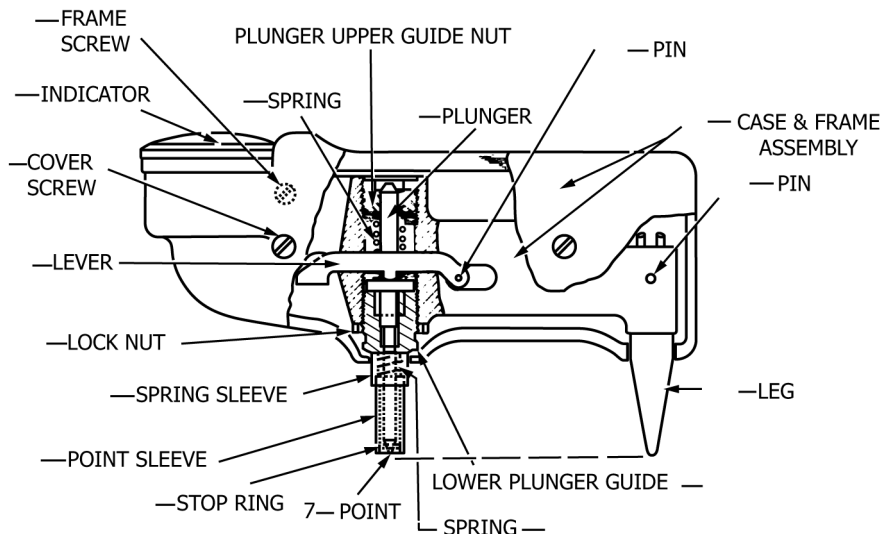

FIG. 1 Diagram of Typical Barcol Impressor Arrangement

100 ± 1. If it does not, loosen the locknut and turn the lower plunger guide in or out to obtain a reading of 100.

7.2 Read the hardness of a “hard” aluminum alloy reference disk supplied by the manufacturer of the impressor and, if necessary, adjust so that the reading is within the range marked on the disk.

TABLE 1 Recommended Sample Sizes to Equalize the Variance of the Average

Hardness, M-934-1 Scale	Reading Variance	Coefficient of Variation, %	Variance of Average	Minimum No. of Readings
50	1.66	1.1	0.28	6
60	1.39	0.9	0.28	5
70	1.12	0.8	0.28	4
80	0.85	0.7	0.28	3

7.3 Repeat the process with a “soft” reference disk.

7.4 If the reference readings cannot be obtained, subsequent measurements are not valid.

8. Procedure

8.1 Support the test parts or specimens on a hard, firm surface if they are likely to bend or deform under the pressure of the indenter. The indenter must be perpendicular to the surface being tested.

8.1.1 Curved surfaces may be more difficult to support. When the load is applied, bending and spring action in the part or specimen should be avoided.

8.2 Grasp the impressor firmly between leg and point sleeve and set both on the surface to be tested. For irregular parts or small specimens this may require the impressor leg to be shimmed so that the indenter will be perpendicular to the test surface.

8.3 Quickly apply by hand sufficient pressure (4 kg to 7 kg, or 10 lb to 15 lb) on the housing to ensure firm contact with the test specimen and record the highest dial reading to the nearest

0.5 division. Take care to avoid sliding or scraping while the indenter is in contact with the surface being tested.

8.3.1 Readings should be made quickly, and the highest observed value should be used.

NOTE 2—For relatively soft materials, the dial may indicate some drift toward lower numbers with time after the initial pressure.

8.4 Impressions shall not be made within 3 mm (1/8 in.) of the edge of the part or specimen or of other impressions.

9. Report

9.1 The report shall include the following:

- 9.1.1 Identification of material tested,
- 9.1.2 Model and serial number of impressor,
- 9.1.3 Number of readings taken,
- 9.1.4 Average of hardness values rounded to the nearest whole scale reading, and
- 9.1.5 Date of test.

10. Precision and Bias

10.1 The precision of this test method is based on an interlaboratory study of B648, conducted in 2008. Each of five laboratories tested a total of four alloys. Every test result represents the average of three individual determinations. Three test results (nine total test readings) from every laboratory were analyzed in order to determine the precision statistics listed below. Except for the limited number of replicates available from some laboratories, Practice E691 was followed for the design and analysis of the data; the details are given in ASTM Research Report No. B07-1002.³

10.1.1 *Repeatability limit (r)*—Two test results obtained within one laboratory shall be judged not equivalent if they differ by more than the “r” value for that material; “r” is the interval representing the critical difference between two test

³ Supporting data have been filed at ASTM International Headquarters and may be obtained by requesting Research Report RR:B07-1002.

TABLE 2 Hardness (Instrument Scale Units)

Material	Average ^A	Repeatability Standard Deviation	Reproducibility Standard Deviation	Repeatability Limit	Reproducibility Limit
	\bar{X}	S_r	S_R	r	R
3003-02	60.282	0.597	1.314	1.671	3.678
5052-H32	73.784	0.427	0.562	1.197	1.574
6061-T6	83.347	0.671	1.379	1.879	3.862
7075-T6	92.211	0.522	0.741	1.461	2.075

^A The average of the laboratories' calculated averages.

results for the same material, obtained by the same operator using the same equipment on the same day in the same laboratory.

10.1.1.1 Repeatability limits are listed in **Table 2**.

10.1.2 *Reproducibility limit (R)*—Two test results shall be judged not equivalent if they differ by more than the “R” value for that material; “R” is the interval representing the critical difference between two test results for the same material, obtained by different operators using different equipment in different laboratories.

10.1.2.1 Reproducibility limits are listed in **Table 2**.

10.1.3 The above terms (repeatability limit and reproducibility limit) are used as specified in Practice **E177**.

10.1.4 Any judgment in accordance with **10.1.1** and **10.1.2** would normally have an approximate 95 % probability of being correct, however the precision statistics obtained in this ILS must not be treated as exact mathematical quantities which are applicable to all circumstances and uses. The limited number of materials tested, and laboratories reporting replicate results, guarantees that there will be times when differences greater than predicted by the ILS results will arise, sometimes with considerably greater or smaller frequency than the 95 %

probability limit would imply. The repeatability limit and the reproducibility limit should be considered as general guides, and the associated probability of 95 % as only a rough indicator of what can be expected.

10.2 *Bias*—At the time of the study, there was no accepted reference material suitable for determining the bias for this test method, therefore no statement on bias is being made.

10.3 The precision statement was determined through statistical examination of 60 results, from five laboratories, on the four alloys described below.

3003-02 - Alcoa Rolled Plate 0.250 in. x 12 in. x 12 in. from 48 in. wide production
 5052-H32- Alcoa Rolled Plate 0.250 in. x 12 in. x 12 in. from 48 in. wide production
 6061-T6 - Kaiser Rolled Plate 0.250 in. x 12 in. x 12 in. from 48 in. wide production
 7075-T6 - Kaiser Rolled Plate 0.250 in. x 12 in. x 12 in. from 48 in. wide production

11. Keywords

11.1 aluminum alloys; Barcol hardness; hardness test device; portable hardness testing

[ASTM B648-23](#)

<https://standards.iteh.ai/catalog/standards/sist/9ac05ba6-37b7-44bc-b6ae-195756d15a8b/astm-b648-23>