



Designation: D2354 – 10 (Reapproved 2023)

Standard Test Method for Minimum Film Formation Temperature (MFFT) of Emulsion Vehicles¹

This standard is issued under the fixed designation D2354; the number immediately following the designation indicates the year of original adoption or, in the case of revision, the year of last revision. A number in parentheses indicates the year of last reapproval. A superscript epsilon (ϵ) indicates an editorial change since the last revision or reapproval.

1. Scope

1.1 This test method covers the determination of the minimum temperature at which emulsion vehicles coalesce to form continuous films. The term “emulsion” in this test method includes latex vehicles.

1.2 This test method is limited to emulsions having minimum film formation temperatures below 90 °C.

1.3 The values stated in inch-pound units are to be regarded as standard. The values given in parentheses are mathematical conversions to SI units that are provided for information only and are not considered standard.

1.4 *This standard does not purport to address all of the safety concerns, if any, associated with its use. It is the responsibility of the user of this standard to establish appropriate safety, health, and environmental practices and determine the applicability of regulatory limitations prior to use.*

1.5 *This international standard was developed in accordance with internationally recognized principles on standardization established in the Decision on Principles for the Development of International Standards, Guides and Recommendations issued by the World Trade Organization Technical Barriers to Trade (TBT) Committee.*

2. Summary of Test Method

2.1 In this test method the minimum film formation temperature (MFFT) is determined by visual observation of cracking or whitening in films that have dried over a substrate having a controlled temperature gradient.

3. Significance and Use

3.1 The satisfactory film integrity of emulsion coatings requires that as the aqueous phase evaporates the resinous portion of the vehicle coalesces into a continuous film. Low temperature impairs the fluidity of the resin particle and thereby their ability to coalesce. Vehicles that can withstand

¹ This test method is under the jurisdiction of ASTM Committee D01 on Paint and Related Coatings, Materials, and Applications and is the direct responsibility of Subcommittee D01.33 on Polymers and Resins.

Current edition approved June 1, 2023. Published June 2023. Originally approved in 1965. Last previous edition approved in 2018 as D2354 – 10 (2018). DOI: 10.1520/D2354-10R23.

low temperatures are therefore required, and MFFT is an important quality feature of emulsion vehicles.

4. Apparatus

4.1 *Minimum Film Formation Temperature Bar*—An MFFT unit² such as is illustrated in Fig. 1. The bar represented in Fig. 1 is designed to be used with thermocouples. The thermocouple leads used with the assembly are iron-constantan with an external resistance of 10 Ω . Also included is a pyrometer (not shown in Fig. 1).

NOTE 1—Thermometers can be used as an alternative way of measuring temperature.³ It is noted that larger holes ($\frac{5}{32}$ in.) (4 mm) will have to be drilled in the bar to accommodate the thermometers. If thermometers are selected, all holes are drilled on the same side of the bar, as opposed to the system of alternate placement of holes when using thermocouples.

NOTE 2—A self-contained unit eliminating the need for any accessories, such as for sub-ambient cooling or temperature measurement, and requiring only an electrical outlet, piped water, and an air or nitrogen supply has been developed by ICI Paints Division.⁴

4.2 *Dry Air or Dry Nitrogen Supply*, with a regulating valve and flow meter.

4.3 *Film Caster*, having a 6 mil (150 μm) clearance.

5. Reagents and Materials

5.1 *Dry Ice*.

5.2 *Isopropanol*, anhydrous.

² The sole source of supply of the MFFT bar, Model CS 188, known to the committee at this time is Dek-Tron Scientific Instrument Corp., 244 East 3rd Street, Plainfield, NJ 07060. If you are aware of alternative suppliers, please provide this information to ASTM International. Your comments will receive careful consideration at a meeting of the responsible technical committee,¹ which you may attend.

³ The sole source of supply of the thermometer, Prince No. A-011044 known to the committee at this time is Princo Instruments Inc., 1020 Industrial Hwy., Southampton, PA 18966. If you are aware of alternative suppliers, please provide this information to ASTM International. Your comments will receive careful consideration at a meeting of the responsible technical committee,¹ which you may attend.

⁴ The sole source of supply of the MFFTBAR units, Models MFFT-60, and MFFT-90, known to the committee at this time is Rhopoint House, Enviro 21 Park, Queensway Avenue South, Queensway, St. Leonards-on-Sea, East Sussex, TN38 9AG, UK. For the name of a local distributor search their website at www.rhopointinstruments.com. Interested parties are invited to submit information regarding the identification of acceptable alternatives to the Committee on Standards, ASTM International. Your comments will receive careful consideration at a meeting of the responsible technical committee,¹ which you may attend.

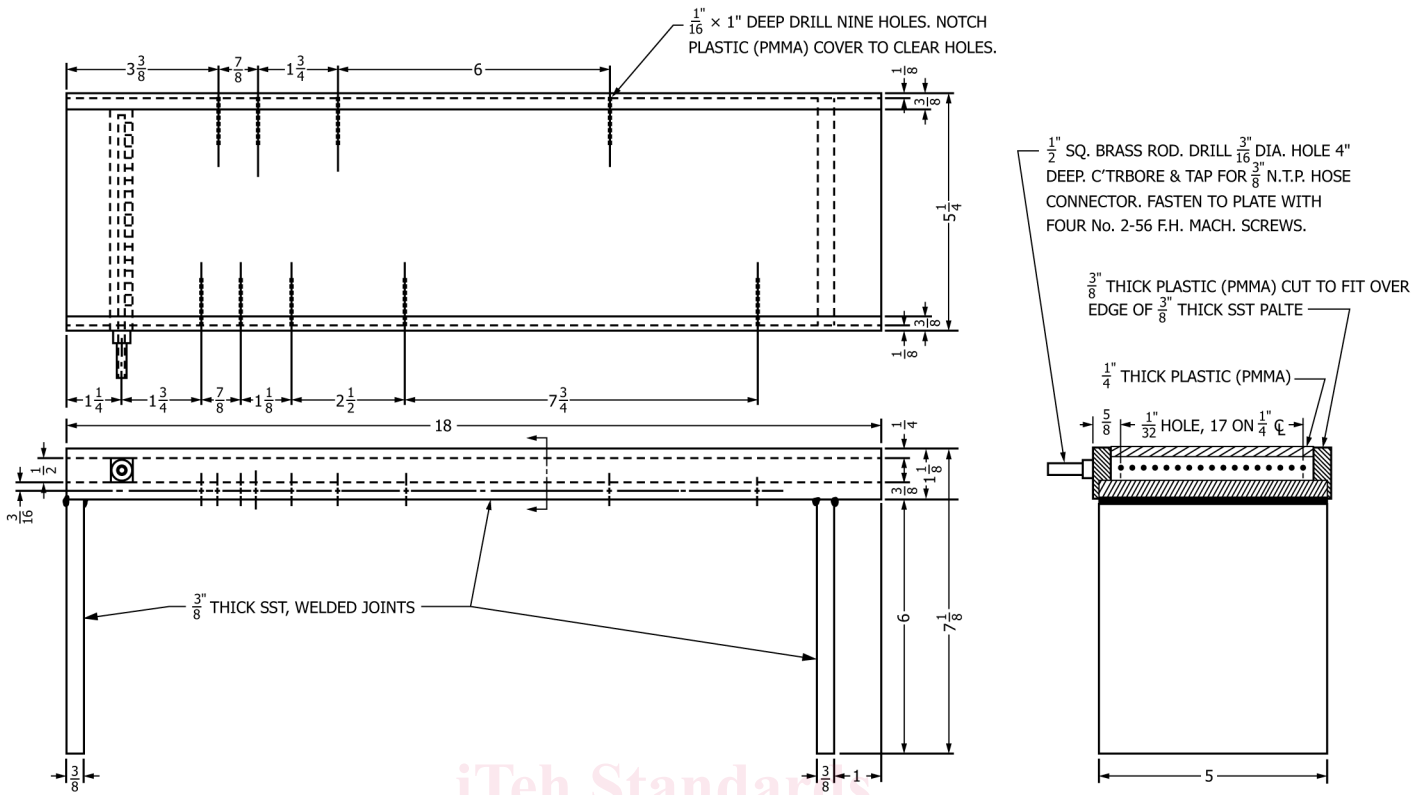

NOTE 1—1 in. = 25.4 mm.

FIG. 1 Minimum Film Formation Temperature Bar

6. Procedure

6.1 Set up the MFFT bar in a level position with the lower temperature leg of the bar immersed in a dry ice-isopropanol bath. It is important that the surface of the bar be smooth and plane to ensure uniform film thicknesses. Use a 1/2 gal (2 L) container for this purpose. (The container can be insulated with any suitable material to reduce heat loss.) Adjust the height of the dry ice-isopropanol bath as needed to bring the temperature of the bar to approximately 0 °C at the lowest temperature-measuring stage of the unit. Lower or higher temperatures can be obtained, if needed, by adjusting the bath height. The bath height needed to obtain 0 °C will vary depending on the heat conductivity of the metal used in the construction of the bar. Expose the higher temperature end of the bar at approximately 25 °C by either conducting the test in a constant-temperature room at this temperature or by thermostating the leg.

6.2 Immediately after imposing the temperature gradient on the bar, place the cover over it and adjust the flow of dry air (or nitrogen) at a rate of 4 L/min from the low-temperature end to the high-temperature end of the bar. Allowing the air to retain moisture by warming up prevents water condensation at the cold temperature end that would interfere with film drying. Approximately 45 min is needed for the temperature gradient to reach equilibrium once the bar is placed in operation. The air manifold holes must be clean and free of frost before starting a test.

NOTE 3—A mixture of ethylene glycol and surfactant applied to the air outlet alleviates the frosting condition temporarily.

6.3 Once a constant-temperature gradient is established, remove the cover and cast the films using the 3 mil (75 μm) applicator (Note 3). Cast films from the low to the high-temperature end of the bar because the extension at the high-temperature end is designed to permit overflow to fall into a container below the bar. After the film is cast and the cover put in place, approximately 1 h to 2 h are required for the film to dry. Check the air flow and isopropanol bath height before any tests are started and then maintain them at their respective levels until the test is completed.

NOTE 4—If desired, a 1/2 mil (13 μm) polyethylene terephthalate sheet of 5 in. (125 mm) width can be placed on the bar surface before casting the film. Tests show that there are no differences between minimum filming temperatures determined with and without the sheet. The polyethylene terephthalate film permits not only easier clean-up of the apparatus, but also a semi-permanent record of the test. Special care must be exercised to ensure good contact of the sheet with the bar. Accomplish this by either of the following techniques:

- (1) Wipe the sheet with a dry cloth to develop a static charge before placement on the bar.
- (2) Coat the sheet with silicone oil before placement on the bar.

6.4 After the film has dried, observe for discontinuity as evidenced by whitening or cracking or both. Record the lowest temperature on the bar at which the film is still continuous as the minimum film formation temperature.

7. Report

7.1 Report the following information:

7.1.1 MFFT in degrees Celsius, and