



Designation: **F3561--22 F3561 - 23**

Standard Test Method for Forced-Entry-Resistance of Fenestration Systems After Simulated Active Shooter Attack¹

This standard is issued under the fixed designation F3561; the number immediately following the designation indicates the year of original adoption or, in the case of revision, the year of last revision. A number in parentheses indicates the year of last reapproval. A superscript epsilon (ϵ) indicates an editorial change since the last revision or reapproval.

1. Scope

1.1 This test method sets forth the requirements and testing procedures to test forced-entry-resistant building components, construction components, and specialty security equipment. This test method is intended primarily for manufacturers to test and rate their windows, doors, modular panels, glazings, and similar products to ensure that all manufactured products meet the necessary requirements for forced-entry protection after sustaining an active shooter assault.

1.2 This test method is currently designed to simulate an active shooter weakening the system with repetitive shots followed by mechanically driven impact to simulate forced entry.

1.3 This test method is not to be used for ballistic resistant glazing rating. Test projectiles are permitted to perforate the entire specimen. The test projectile firings are intended to simulate actions taken by an assailant to aid in the ability to gain entry to a facility.

1.4 This is a laboratory test to be performed on full systems and therefore not applicable for field testing.

1.5 All tests are executed on the exterior surface of the fenestration.

1.6 Systems are required to be tested as complete units in a test frame or fielded conditions. Mullled systems must be tested in the mullled condition. Test results only apply to the component or system as tested. Once a system is tested and deemed to satisfy the requirements of this test method, no design change can be made without a retest except those that qualify under **Annex A1** Substitution Criteria.

1.7 Components (such as glazing, door leaves, etc.) may be tested in accordance with **Appendix X1**, receiving a capability statement for the component, but not a system rating per this standard.

1.8 Window and door systems shall be rated to at least a minimum level of Test Methods **F476**, **F588**, or **F842**, or combinations thereof, as appropriate prior to commencing this test evaluation. This test does not dual certify to the above mentioned standards.

1.9 The values stated in this standard are SI units with the exception of the nominal descriptors for tools.

¹ This test method is under the jurisdiction of ASTM Committee **F12** on Security Systems and Equipment and is the direct responsibility of Subcommittee **F12.10** on Systems Products and Services.

Current edition approved Aug. 1, 2022; June 15, 2023. Published August 2022; June 2023. Originally approved in 2022. Last previous edition approved in 2022 as **F3561 - 22**. DOI: [10.1520/F3561-22](https://doi.org/10.1520/F3561-22); [10.1520/F3561-23](https://doi.org/10.1520/F3561-23).

1.10 *This standard does not purport to address all of the safety concerns, if any, associated with its use. It is the responsibility of the user of this standard to establish appropriate safety, health, and environmental practices and determine the applicability of regulatory limitations prior to use.*

1.11 *This international standard was developed in accordance with internationally recognized principles on standardization established in the Decision on Principles for the Development of International Standards, Guides and Recommendations issued by the World Trade Organization Technical Barriers to Trade (TBT) Committee.*

2. Referenced Documents

2.1 ASTM Standards:²

A36/A36M Specification for Carbon Structural Steel

A574 Specification for Alloy Steel Socket-Head Cap Screws

C719 Test Method for Adhesion and Cohesion of Elastomeric Joint Sealants Under Cyclic Movement (Hockman Cycle)

C1036 Specification for Flat Glass

C1048 Specification for Heat-Strengthened and Fully Tempered Flat Glass

C1135 Test Method for Determining Tensile Adhesion Properties of Structural Sealants

C1172 Specification for Laminated Architectural Flat Glass

D1415 Test Method for Rubber Property—International Hardness

D3575 Test Methods for Flexible Cellular Materials Made from Olefin Polymers

E631 Terminology of Building Constructions

E3062/E3062M Specification for Indoor Ballistic Test Ranges for Small Arms and Fragmentation Testing of Ballistic-resistant Items

F476 Test Methods for Security of Swinging Door Assemblies

F588 Test Methods for Measuring the Forced Entry Resistance of Window Assemblies, Excluding Glazing Impact

F842 Test Methods for Measuring the Forced Entry Resistance of Sliding Door Assemblies, Excluding Glazing Impact

F1915 Test Methods for Glazing for Detention Facilities

2.2 Other Standards:

ISO/IEC 17025:2005 General Requirements for the Competence of Testing and Calibration Laboratories³

3. Terminology

3.1 Definitions of Terms Specific to This Standard:

3.1.1 *component, n*—integral part of a forced entry test specimen such as: panels, frame, glazing, glazing bite, flanges, hinges, locks, jamb/wall, jamb/strike mullions, and mounting devices of different shape, size, and material.

<https://standards.iteh.ai/catalog/standards/sist/20f12a17-6dec-4f88-ab62-04d83c168ad1/astm-f3561-23>

3.1.2 *door, double, n*—two-door assembly with an opening wider than as a single door with a common latch and lock edge; may or may not include a removable mullion; openings may be asymmetrical with regard to the size of openings.

3.1.3 *door panel, n*—the swinging or sliding barrier by which an entry is closed and opened, not including framing, operating, or latching mechanisms.

3.1.4 *failure criteria, n*—any failure of the manufacturer’s recommended mounting hardware or penetration of any portion of the system sufficient to permit passage of the test shape.

3.1.5 *fenestration, n*—any glazed panel, window, door, curtain wall, or skylight unit on the exterior of a building.

3.1.6 *glazing weakening, v*—intentional structural deterioration of a glazing or glazing infill.

3.1.7 *impact assault, n*—test of forced entry attack using an impactor on one dissimilar component in an attempt to create an opening and permit passage of the test shape.

3.1.8 *impactor, n*—45 kg striking mechanism capable of being deployed in a pendulum motion.

² For referenced ASTM standards, visit the ASTM website, www.astm.org, or contact ASTM Customer Service at service@astm.org. For *Annual Book of ASTM Standards* volume information, refer to the standard’s Document Summary page on the ASTM website.

³ Available from International Organization for Standardization (ISO), ISO Central Secretariat, Chemin de Blandonnet 8, CP 401, 1214 Vernier, Geneva, Switzerland, <https://www.iso.org>.

3.1.9 *independent test facility*, *n*—testing laboratory accredited to perform the referenced testing procedures by a nationally recognized accrediting agency in accordance with ISO/IEC 17025.

3.1.10 *mulled*, *n*—the physical connection together of two parts of the same system; the two systems may be anchored directly to each other or have a mullion between them.

3.1.11 *mullion*, *n*—a component used to divide two parts of the same system and it can be vertical or horizontal, movable or fixed; for purposes of this test method, a mullion does not include steel or concrete structural members (including seismic joints) which are present in the building.

3.1.12 *ready-to-install*, *n*—fabricated, with an appropriate final finish such as galvanizing, paint, or anodizing; the test specimen shall consist of the entire fenestration assembly and contain all devices used to resist forced entry; all parts of the test specimen shall be full size, as specified for actual use, using the identical materials, details, and methods of construction.

3.1.13 *shop assembly drawing*, *n*—a drawing which shows how a system is assembled including the locations, dimensions, and arrangements of all assembly elements such as bolts, glazing stops, and glazing spacers.

3.1.14 *system*, *n*—the assembly of structural elements and devices which comprise the forced-entry-resistant barrier.

3.1.15 *test director*, *n*—the individual identified by the independent testing laboratory as being responsible to complete the specified tests as required and to document the results, in accordance with this test method.

3.1.16 *test facility*, *n*—laboratory or other area where forced-entry testing is conducted.

3.1.17 *test fixture*, *n*—the structural assembly which holds the test specimen.

3.1.18 *test levels*, *n*—the increments to which systems are tested.

3.1.19 *test plane*, *n*—a plane parallel and contiguous to the face of the attack side of the test sample.

3.1.20 *test projectiles*, *n*—projectiles or ammunition that is used to weaken the test specimen.

3.1.21 *test shape*, *n*—a non-compressible sphere measuring 152 mm (6 in.) in diameter.

3.1.22 *test tools*, *n*—the devices used by the test team during the assault tests.

3.1.23 *testing report*, *n*—a report provided by the test facility that includes configuration documentation, any applicable abnormality, forced-entry testing data and photographs, a certification of testing, a narrative summary of testing, time-stamped drawings that have been validated to match the test specimen, and all video recording(s) of testing.

3.1.24 *view window*, *n*—a window system which permits visual contact through an otherwise opaque host assembly.

3.1.25 *window frame*, *n*—the opaque portion of a transparent assembly into which the transparent element is mounted.

3.1.26 *yaw*, *n*—the angular deviation between the test projectile's axis of symmetry and its line of travel.

3.2 Abbreviations:

3.2.1 AN—annealed

3.2.2 C1—center 1

3.2.3 C2—center 2

3.2.4 CS—chemically strengthened

3.2.5 *E*—East

3.2.6 FMJ—Full Metal Jacket bullet

3.2.6 FT—fully tempered

3.2.7 ft/s—feet per second

3.2.8 ft·lbf—foot pound-force

3.2.9 H—drop height

3.2.10 HS—heat-strengthened

3.2.11 in.—inch(es)

3.2.12 IRHD—international rubber hardness degree

3.2.13 J—joules

3.2.14 kg—kilogram

3.2.15 L—horizontal swing distance

3.2.16 lb—pound

3.2.17 m/s—meters per second

<https://standards.iteh.ai/catalog/standards/sist/20f12a17-6dec-4f88-ab62-04d83c168ad1/astm-f3561-23>

3.2.18 mm—millimeter

3.2.19 MSG—manufacturers standard grade

3.2.20 n—noun

3.2.21 *N*—North

3.2.22 N—Newtons

3.2.23 *NE*—North East

3.2.24 *NW*—North West

3.2.25 oz—ounce

3.2.26 R—radius of swing

3.2.27 *S*—South

3.2.28 *SE*—South East

iTeh Standards
(<https://standards.iteh.ai>)
Document Preview

[ASTM F3561-23](https://standards.iteh.ai/catalog/standards/sist/20f12a17-6dec-4f88-ab62-04d83c168ad1/astm-f3561-23)

3.2.29 *SW*—South West

3.2.30 *v*—verb

3.2.31 *W*—West

4. Summary of Test Method

4.1 This test method establishes incremented levels of forced-entry protection via evaluation of a two-stage attack of a single or mullied system by using a device for weakening of components prior to forced entry impact of the fenestration system.

5. Significance and Use

5.1 The test requirements specified herein have been established for use in evaluating the forced-entry resistance characteristics of assemblies to be used in commercial, residential, schools, government, and other institutional installations where the risk of a single person active shooter attack is present.

5.2 The procedures of this test method are intended to evaluate the ability to create an opening of sufficient size to permit passage of a test shape through it.

5.3 The procedure presented herein is based on post-event examination and are not intended to be used to establish or confirm the absolute prevention of forced entries.

6. Apparatus

6.1 Apparatus to conduct these tests include ballistic firing mechanism or means to simulate ballistic type weakening, test fixture, impactor, measurement device, test shape, and force meter.

6.2 *Test Fixture*—The test fixture shall be sized to accommodate the test specimen and in accordance with design of Figure 1 in Test Methods **F1915**, or as specified by the authority having jurisdiction provided it does not enhance or degrade the specimen.

6.3 *Velocity Measurement System*—The velocity measurement system shall be capable of providing projectile velocities with at least a 1×10^{-6} sec sampling resolution and an accuracy of at least ± 1.5 m/s (± 5 ft/s).

6.4 *Support Fixture and Frame*—The test specimen shall be mounted in the frame along the full length of all edges or as specified by the manufacturer's installation instructions.

6.4.1 The frame shall have a clamping plate to hold the test specimen in position and means for producing uniform clamping of the specimen.

6.4.2 All edges of the test specimen shall be uniformly clamped with a clamping pressure sufficiently large that the edges remain in position during the test. The test specimen in the frame shall be placed normal to the direction of attack with an accuracy of ± 0.02 rad (1° (degree)) in any orientation. Test specimen shall be oriented to strike face in accordance with manufacturer's documentation. Manufacturer shall clearly mark the strike face on each specimen. The support and retention system shall be reported.

6.4.3 The test fixture shall simulate installation in a permanent steel or concrete structure which neither enhances nor degrades the forced-entry protection of the system.

6.5 *Glass System Weakening Device*—The glass system weakening device shall be capable of firing 10 test projectiles meeting the requirements of **Table 1**.

6.5.1 Test projectiles shall be fired using:

6.5.1.1 *AR-15 5.56 Rifle*, capable of discharging projectiles in accordance with **6.5**.

TABLE 1 Test Projectiles

Ammunition Description	Ammunition Identity Classification (AIC)	Bullet Weight (grain)	Velocity (Meters (ft/s))
5.56 NATO, Copper Jacket Lead Core, FMJ	M193	55	1027 m/s (3370 ft/s)

TABLE 1 Test Projectiles

Ammunition Description	Ammunition Identity Classification (AIC)	Bullet Weight grams (grain)	Velocity (m/s (ft/s))
5.56	M193	3.6 +0/-0.1 g (56 +0/-2 grains)	1033 m/s (3390 ft/s)

6.5.1.2 *Ballistic Firing Mechanism*, capable of discharging projectiles in accordance with 6.5.

6.6 *Forced Entry Impactor System:*

6.6.1 *Impactor:*

6.6.1.1 The forced entry impactor shall be a pendulum system with a cylindrical weight capable of delivering horizontal impacts of 542 J (400 ft-lbf).

6.6.1.2 The diagram of the impactor is shown in Fig. 1. It is a steel cylinder 152 mm ± 6 mm (6 in. ± 0.25 in.) in diameter, 360 mm ± 45 mm (14 in. ± 1.75 in.) long, with a hemispherical impact nose 76 mm ± 6 mm (3 in. ± 0.25 in.) in diameter and maximum 76 mm (3 in.) deep. The impactor including eye bolts weighs 45 kg ± 1 kg (100 lb ± 2 lb).

6.6.1.3 The shot is used to obtain the proper weight of the impactor as needed. The shot should be constrained in holders attached to the impactor to avoid excessive movement during testing. The shot is to be positioned evenly to balance the weight of the impactor front to back in the suspension system.

6.6.1.4 The impact nose used in this equipment is made from a durable impact-resistant material (for example, cast epoxy polyamide resin; however, any durable impact-resistant material is satisfactory resin, polyoxymethylene, polyurethane).

6.6.1.5 The durometer of the impact nose shall be Shore D hardness 80 ± 10.

6.7 *Suspension System:*

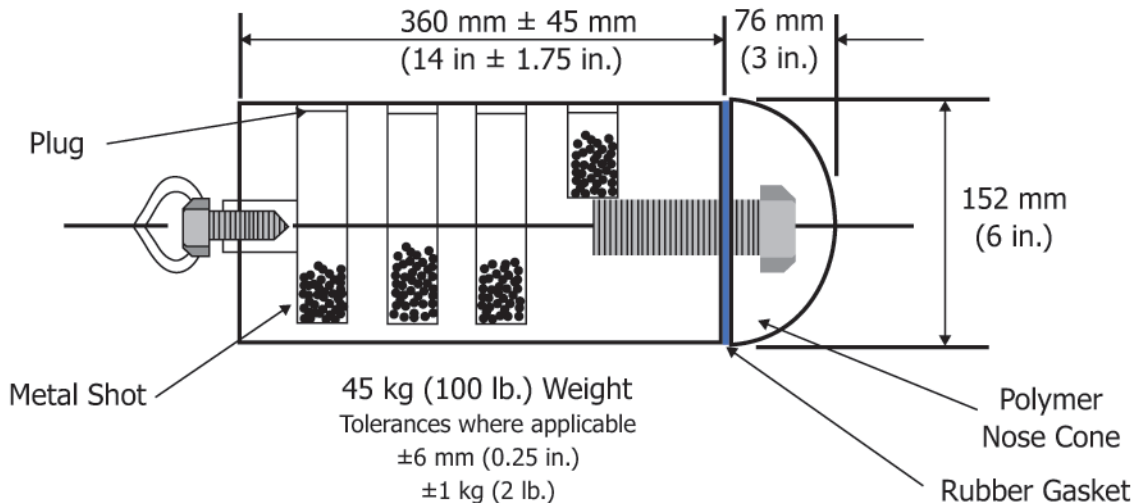

FIG. 1 Impactor Details

6.7.1 The suspension system for the impactor consists of four flexible steel cables providing a swing radius of $1710 \text{ mm} \pm 52 \text{ mm}$ ($67 \text{ in.} \pm 2 \text{ in.}$), as shown in Fig. 2.

NOTE 1—Fig. 2 is for example only. Suspension system should be capable of allowing adequate, smooth, and consistent delivery of designated force.

6.7.2 Fig. 3 includes a diagram of the pendulum system when elevated and at rest, and the measurements required to calculate the impact energy of the system.

6.7.3 These cables are adjusted to equal length with turnbuckles such that the impactor swings in a straight, true arc and are attached to a steel frame that can be adjusted to be level (Fig. 2).

6.7.4 Table 2 presents the potential energy of a pendulum system with a $45 \text{ kg} \pm 1 \text{ kg}$ ($100 \text{ lb} \pm 2 \text{ lb}$) weight as a function of various elevations of the weight. The suspension cables are not included in the weight and energy calculations of the impactor.

6.8 Test Shape—The test shape used to determine if passage has been achieved is defined in 3.1.21.

7. Hazards

7.1 This test method involves potentially hazardous situations. Proper precautions shall be taken by the test facility to protect workers, observers, and the community. The test location shall be secured to prevent unauthorized access during testing. All testing personnel and observers shall be kept out of the path of the projectile and behind a hardened barrier to minimize ricochet or fragmentation hazards during testing. The main backstop shall be designed to safely contain the projectile and prevent damage to life or property down range in the projectile's line of flight.

7.2 The testing lab shall be properly designed to minimize health effects to workers resulting from lead dust exposure. Proper

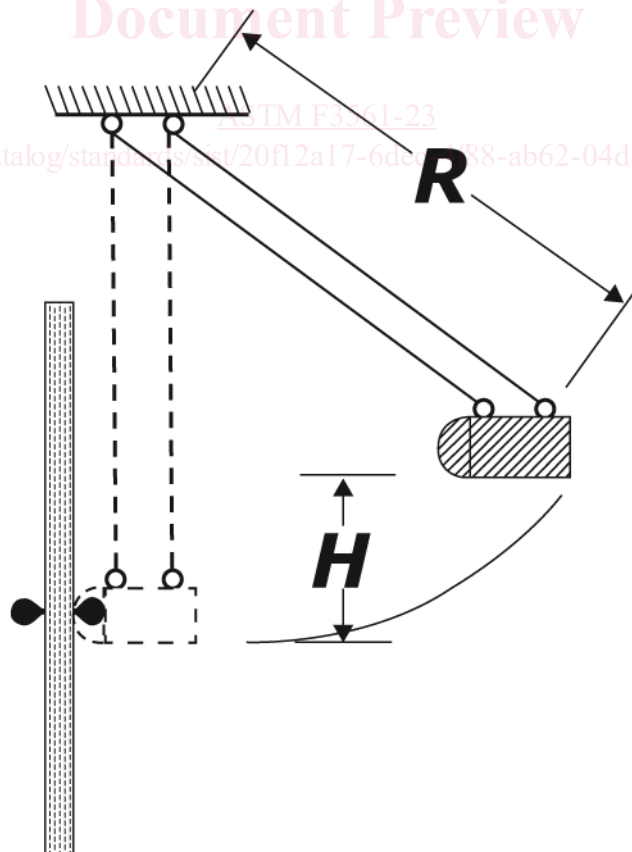

FIG. 2 Impactor Swing and Measurement Schematic

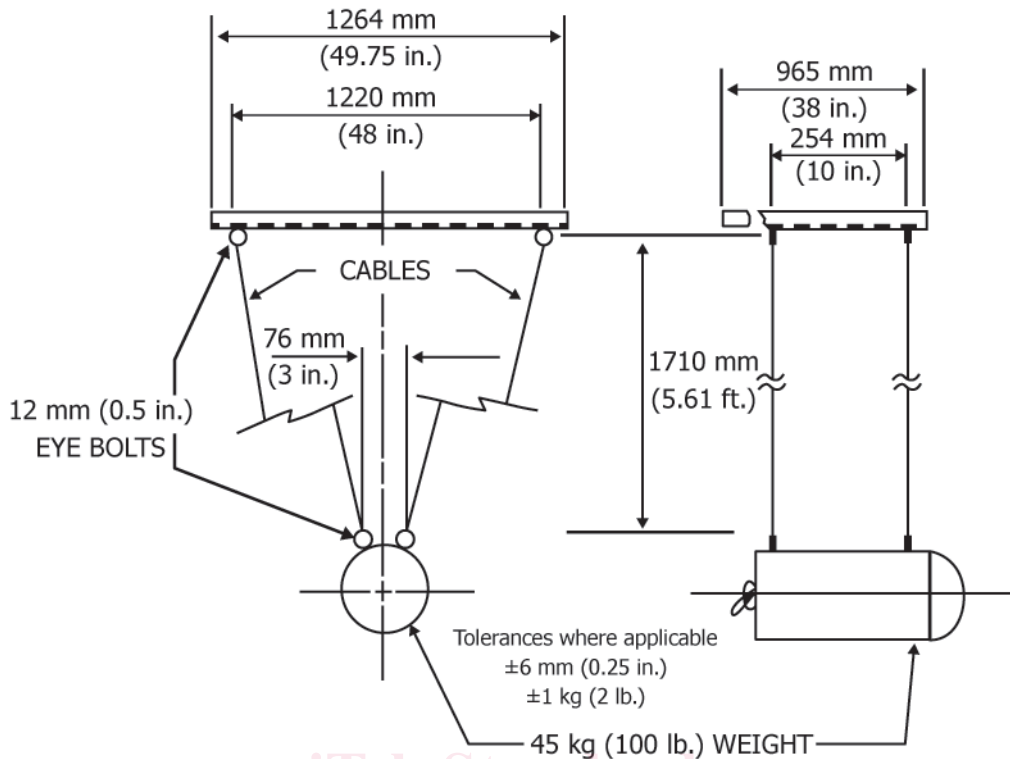

FIG. 3 Detail of Impactor Cable System

TABLE 2 Potential Energy of Impactor and Drop Height

Level	Potential Energy, J		Height of Drop (H)	
	J	(ft*lbf)	mm	(ft)
1	68	50	152	0.50
2	136	100	305	1.00
3	203	150	457	1.50
4	271	200	610	2.00
5	339	250	762	2.50
6	407	300	914	3.00
7	475	350	1067	3.50
8	542	400	1219	4.00

handling, storage, and disposal of lead contaminated materials shall be consistent with all local and federal laws and requirements found in the Resource Conservation & Recovery Act of 1976.

8. Test Specimens

8.1 Systems submitted for testing shall be full-size systems complete with all required anchor bolt system hardware and representative of production systems.

8.2 Systems that move or operate (for example, doors, hatches, operable windows) shall, at minimum, include all devices required for operation.

8.3 The test specimen shall be ready-to-install.

8.4 Three (3) test specimens of identical construction shall constitute a sample set for testing.

8.4.1 Testing identical samples except for size in order to qualify a product line is acceptable. Three samples of each the largest and smallest units shall be submitted for testing. All unit increments inclusive of and between these sizes shall be qualified when both sets successfully meet the criteria of this document.

9. Preparation of Apparatus

9.1 Preparation:

9.1.1 Review the test specimen configuration and test sample documents supplied in accordance with 9.1.2 to ensure the proper sample is being tested.

9.1.2 Ensure testing apparatus is in good condition and configured per 6.2.

9.1.3 Install test specimen in support fixture per 6.4.

9.1.4 *Support Fixture and Frame*—The test specimen shall be mounted in the frame along the full length of all edges.

9.1.4.1 The frame shall have a clamping plate to hold the test specimen in position and means for producing uniform clamping of the test specimen.

9.1.4.2 All edges of the test specimen shall be uniformly clamped with a clamping pressure sufficiently large that the edges remain in position during the test.

9.1.5 Forced-entry test specimens shall be mounted in accordance with all the requirements of this section.

9.1.5.1 The mounting of the test specimen must give no leverage advantages and shall not influence the performance of the test specimen over the expected mounting conditions in the field.

9.1.5.2 The test specimen shall be mounted in accordance with the manufacturer's instructions with particular attention paid to the threat and protected side orientation during mounting.

(1) If the test specimen cannot be mounted according to the installation instructions submitted by manufacturer, the test shall not be conducted.

9.1.5.3 If the tested product type is typically installed in an opening larger than the tested product size (for example, in a “rough opening”), the test specimen shall be mounted in a rough opening of $8\text{ mm} \pm 2\text{ mm}$ ($0.315\text{ in.} \pm 0.08\text{ in.}$) larger on all sides than the test specimen.

9.1.5.4 For specimens that require footers, the test specimens shall be erected (including those cast in place) on footings, and either back-braced or capped with a simulated roof or ceiling panel to ensure that the bracing or capping reflect standard fielded conditions.

10. Specimen Preparation and Mounting

10.1 *Glazing System Tests*—The test specimen will be mounted in accordance with the manufacturer's recommendations and shall be securely anchored. Consideration should be given to, but is not limited to:

10.1.1 Overall size of glazing system;

10.1.2 Amount of “bite” within the frame;

10.1.3 Integrity of the frame;

10.1.4 Strength of base material;

10.1.5 Size of removable stop;

10.1.6 Removable stop fastener;

10.1.7 Interface between glazing and frame; and

10.1.8 Integrity of anchorage of glazing system to adjoining architectural features.

NOTE 2—The clamping pressure has relatively little effect on the test results for glass but can have considerable influence on the test results for plastic glazing sheet materials. For these materials, the manner of support and retention shall be reported.

10.2 The specimen shall have an edge support/coverage on all edges of 38 mm \pm 6 mm (1.5 in. \pm 0.25 in.). The specimen shall be separated from the frame and the clamping plate by continuous rubber strips, 5 mm \pm 0.5 mm (0.197 in. \pm 0.02 in.) thick, 30 mm \pm 5 mm (1.18 in. \pm 0.197 in.) wide and of hardness (50 \pm 10) IRHD, in accordance with Test Method **D1415**.

NOTE 3—The rigidly supported fixture prevents specimen translation along the line of flight but permits its position and attitude to be readily adjusted so that it is perpendicular to the line of flight at the projectile point of impact.

10.2.1 The test specimen in the frame shall be placed normal to the direction of attack with an accuracy of ± 0.02 radians ($\pm 1^\circ$ (degree)) in any orientation. Test specimen shall be oriented to strike face in accordance with manufacturer's documentation. Manufacturer shall clearly mark the strike face on each specimen. The support and retention system shall be reported.

11. Calibration and Standardization

11.1 Apparatus shall be inspected for defects prior to testing, be in good working condition and not defective.

11.2 Velocity of the ballistic firing mechanism shall be verified.

11.2.1 *Velocity Measurement System*—The velocity measurement system shall be capable of providing projectile velocities with at least a 1×10^{-6} sec sampling resolution and an accuracy of at least ± 1.5 m/s (± 5 ft/s). The system shall maintain position and alignment throughout the testing sequence and shall minimize the effects of shock waves, sound waves, ultraviolet and infrared light, ejected propellant, sabots, and other debris that can decrease measurement accuracy. Redundant velocity measurement system is required.

11.2.2 If radar, high-speed video, or X-ray is used for velocity measurement, the velocity reported shall be the velocity measured at 2.3 m \pm 2.5 cm (90 in. \pm 1.0 in.) from the plane of the test item.

11.2.3 If light screens are used for velocity measurement, the requirements below shall be met.

11.2.3.1 The light screens shall be positioned as shown in Specification **E3062/E3062M**.

11.2.3.2 The inner screens shall be paired together, and the outer screens shall be paired together.

11.2.3.3 The light screen pairs shall be parallel to each other and perpendicular to the projectile firing system barrel.

11.2.3.4 The distance from the last light screen to the test item reference plane shall be no greater than 1.5 m (5 ft).

11.2.3.5 The light screens shall be fastened together to prevent inadvertent changes in spacing.

NOTE 4—The spacing between the light screens may be adjusted to meet velocity measurement requirements.

11.3 Impactor weight shall be verified to be 45 kg \pm 1 kg (100 lb \pm 2 lb).

11.4 Impactor nose cone shape and dimensions shall be verified through measurement, free of gouges or cuts deeper than 12 mm (0.5 in.), and durometer shall be an average of 80 \pm 10 Shore D when measured in three distinct locations on the nose cone, with a minimum of one location being at the center of the impacting face of the nose cone.

12. Conditioning

12.1 Specimens shall be conditioned prior to testing to ensure all components have reached temperature equilibrium.

12.2 Testing shall be performed at an ambient temperature of 22 $^\circ\text{C}$ \pm 4 $^\circ\text{C}$ (72 $^\circ\text{F}$ \pm 7 $^\circ\text{F}$).

13. Test Director Role

13.1 The Test Director is responsible for safety and will ensure that all reasonable safety precautions are employed.

13.2 *Safety*—The test may be interrupted for reasons of safety (imminent danger to or injury of test personnel). This interruption in the test will not be used for clearing away debris, such as glass fragments produced during testing, from the test specimen. *Any modifications to the test specimen made for safety reasons must be agreed to by all parties and must not in any way enhance or detract from the sample's forced-entry resistance.*

13.3 The Test Director's goal is to ensure consistency in the application and performance of this test. The Test Director shall direct impacts and verify the system to the pass/fail criteria presented in this document. The Test Director shall be provided a full set of plans prior to the test.

13.4 The Test Director shall, at a minimum, ensure the following:

13.4.1 Only those resources (impactor) specified may be applied to the test specimen once forced-entry testing has commenced;

13.4.2 Impactor and firing device are used safely and appropriately; and

13.4.3 The elapsed time between the weakening of the glazing and impact commencing shall be minimized and shall in no case exceed 2 h in order to simulate actual durations of attack as closely as possible in a controlled environment.

14. Procedure for Panel Operability

14.1 Prior to any testing of the system, the system shall have its operability measured and recorded. No assembly shall be modified or enhanced once operability has been recorded.

14.2 Additional attachments that increase the strength of the connection between the operable locking devices and the system are not permitted. Operation of the locking devices shall be done in a manner that will not cause collateral damage to the specimen.

14.3 *Panel Operability Test:*

14.3.1 This test applies only to systems that may be opened.

14.3.2 Close and lock all portions of the test specimen. Submit each operable unit to five cycles of opening, closing, and locking prior to testing.

14.3.3 After panel operation test sequence, the test specimen shall be considered operable per the manufacturer's written installation instructions.

14.3.4 Fenestration shall be locked prior to initiating any test projectile firings and the locks not operated again until the completion of the forced entry impactor tests.

14.3.5 At the completion of the final forced entry impact test sequence, the operability of the system shall be verified in accordance with Section 14; however failure to operate is not a condition of passing this test. The ability to operate the locks and open the system shall be noted in the report.

15. Procedure for Fenestration Weakening

15.1 *Glazing or Panel Weakening:*

15.1.1 Glazing or panel shall be pre-weakened by test projectiles prior to impact testing.

15.1.2 Test pattern shall be centered on the target component (normally geometric center of the glazing or panel) with a minimum distance from the inner edge of the frame being 52 mm (2 in.).

15.1.3 Test pattern diameter shall be 457 mm \pm 6 mm (18 in. \pm 0.25 in.) with all the impacts being positioned within the tolerance

of the diameter with $0.785 \text{ radian} \pm 0.05 \text{ radian}$ ($45^\circ \pm 3^\circ$) separation between shots. The center shots (C1 and C2) shall be located $52 \text{ mm} \pm 6 \text{ mm}$ (2 in. ± 0.25 in.) from the geometrical center and along the *W* to *E* axis with $104 \text{ mm} \pm 6 \text{ mm}$ (4 in. ± 0.25 in.) distance between the center of each shot.

15.1.4 *Test Projectile Firing*—Ammunition of the appropriate type and caliber (see 6.5) shall be single-fired to obtain the required number of fair hits on each test specimen. Shots shall utilize the shot pattern shown in Fig. 4.

15.1.5 The sequence of projectiveprojectile firing shall be *N, S, W, E*, followed by *NW, SW, NE, SE*, C1 and C2 as indicated in Fig. 4.

15.1.6 The orientation and sequence of the shots shall not be changed.

15.2 *Procedure for Lock Weakening:*

15.2.1 Lock mechanisms in doors shall be pre-weakened by test projectiles prior to impact testing.

15.2.2 Test pattern shall be offset (to the right or left) of the locking mechanism so that the applicable *West or East* most firing impacts the center of the lock with the remaining shots on the door panel (Fig. 7).

15.2.3 Test pattern diameter shall be $229 \text{ mm} \pm 6 \text{ mm}$ (9 in. ± 0.25 in.) with all the impacts being positioned within the tolerance of the diameter with $1.571 \text{ radian} \pm 0.05 \text{ radian}$ ($90^\circ \pm 3^\circ$) separation between shots. The center shot (C3) shall be located to the side (right or left) and perpendicular to the vertical center of the locking mechanism (typically a panel impact location).

15.2.4 *Test Projectile Firing*—Ammunition of the appropriate type and caliber shall be single-fired to obtain the required number of fair hits on each test specimen. Shots shall utilize the shot pattern shown in Fig. 5.

15.2.5 The sequence of projective firing shall be C3, followed by *N, S, E, W* as indicated in Fig. 5. The final shot shall be on the lock mechanism.

15.2.6 The orientation and sequence of the shots shall not be changed.

15.3 *Fair and Unfair Hits*—For purposes of this test method, a fair hit shall be a zero-degree obliquity ballistic impact ($\pm 3^\circ$) using the specified weight and type of un-yawed bullet (0.05 radian (3°) maximum)) within the specified velocity range on the specified

<https://standards.iteh.ai/catalog/standards/sist/20f12a17-6dec-4f88-ab62-04d83c168ad1/astm-f3561-23>

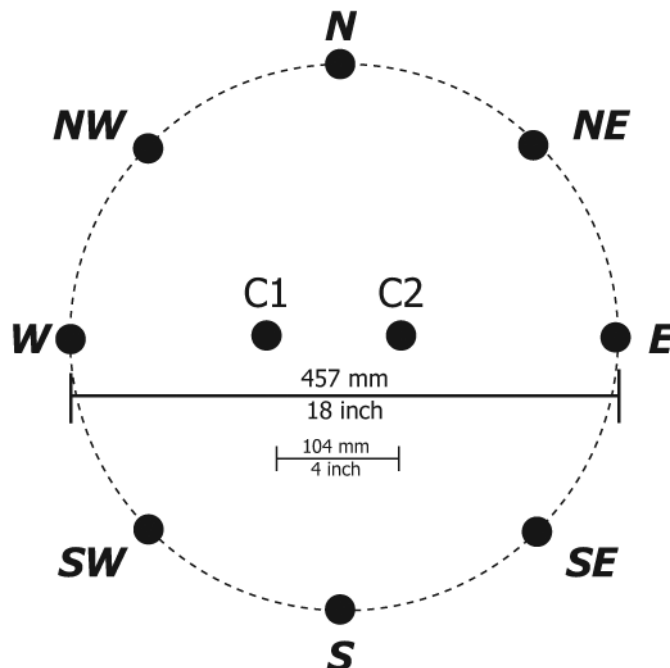

FIG. 4 Test Projectile Firing Pattern for Glazing and Panels