



Designation: D2202 – 00 (Reapproved 2023)

Standard Test Method for Slump of Sealants¹

This standard is issued under the fixed designation D2202; the number immediately following the designation indicates the year of original adoption or, in the case of revision, the year of last revision. A number in parentheses indicates the year of last reapproval. A superscript epsilon (ϵ) indicates an editorial change since the last revision or reapproval.

1. Scope

1.1 This test method covers a laboratory procedure for the determination of the degree of slump of a sealant when used in a vertical joint in a structure.

1.2 The values stated in either inch-pound or SI (metric) units are to be separately regarded as the standard. Within the text, the inch-pound units are shown in parentheses.

1.3 *This standard does not purport to address all of the safety concerns, if any, associated with its use. It is the responsibility of the user of this standard to establish appropriate safety, health, and environmental practices and determine the applicability of regulatory limitations prior to use.*

NOTE 1—A related ISO standard is ISO 7390. The user should compare to determine how it differs from this test method.

1.4 *This international standard was developed in accordance with internationally recognized principles on standardization established in the Decision on Principles for the Development of International Standards, Guides and Recommendations issued by the World Trade Organization Technical Barriers to Trade (TBT) Committee.*

2. Referenced Documents

- 2.1 *ASTM Standards*:²
 - C717 Terminology of Building Seals and Sealants
- 2.2 *ISO Standards*:³
 - ISO 7390 Building Construction—Sealants—Determination of Resistance to Flow

3. Terminology

3.1 *Definitions*—Refer to Terminology C717 for definitions of the following terms found in this test method: bead, joint, sealant.

¹ This test method is under the jurisdiction of ASTM Committee C24 on Building Seals and Sealants and is the direct responsibility of Subcommittee C24.20 on General Test Methods.

Current edition approved June 1, 2023. Published July 2023. Originally approved in 1963 as D2202 – 63 T. Last previous edition approved in 2019 as D2202 – 00 (2019). DOI: 10.1520/D2202-00R23.

² For referenced ASTM standards, visit the ASTM website, www.astm.org, or contact ASTM Customer Service at service@astm.org. For *Annual Book of ASTM Standards* volume information, refer to the standard's Document Summary page on the ASTM website.

³ Available from American National Standards Institute, 11 W. 42nd St., 13th Floor, New York, NY 10036.

4. Significance and Use

4.1 Excessive sealant slump or sag in a vertical joint may cause improper bead shape or inadequate sealant thickness in the completed joint. Slump measurements, as described in this test method, serve to evaluate only this application characteristic; they do not predict the performance capability of the sealant after installation.

5. Apparatus

5.1 *Flow Test Jig*, constructed in accordance with Fig. 1 (SI units) or Fig. 2 (inch-pound units).

NOTE 2—Most existing flow test jigs have been constructed in inch-pound units. Preferred construction of new jigs is as described in Fig. 1 in SI units.

5.2 *Gravity Convection Oven*, having a temperature controlled at $50\text{ }^{\circ}\text{C} \pm 2\text{ }^{\circ}\text{C}$ ($122\text{ }^{\circ}\text{F} \pm 3.6\text{ }^{\circ}\text{F}$).

5.3 *Steel Spatula*:

5.4 *Plastic Scraper*, such as an ordinary 114 by 114-mm ($4\frac{1}{2}$ by $4\frac{1}{2}$ -in.) plastic tile.

6. Reagent

6.1 *Solvent*, such as methyl ethyl ketone.

7. Sampling

7.1 Take test specimens from a previously unopened container and mix thoroughly before using, if required for homogeneity.

8. Conditioning

8.1 Condition both the test jig and the sealant to be tested for at least 5 h at $23 \pm 2\text{ }^{\circ}\text{C}$ ($73.4 \pm 3.6\text{ }^{\circ}\text{F}$).

9. Procedure

9.1 Thoroughly clean the test jig with the solvent; then place it on a level table with the front face upward and the plunger depressed to the limit of its travel.

9.2 Place the mixed, conditioned sealant in the jig cavity. Level the sealant flush with the surface of the block, using one gentle upward stroke of the plastic scraper held at a 45° angle. Avoid forming air pockets in the sealant, especially near the surface of the plunger.

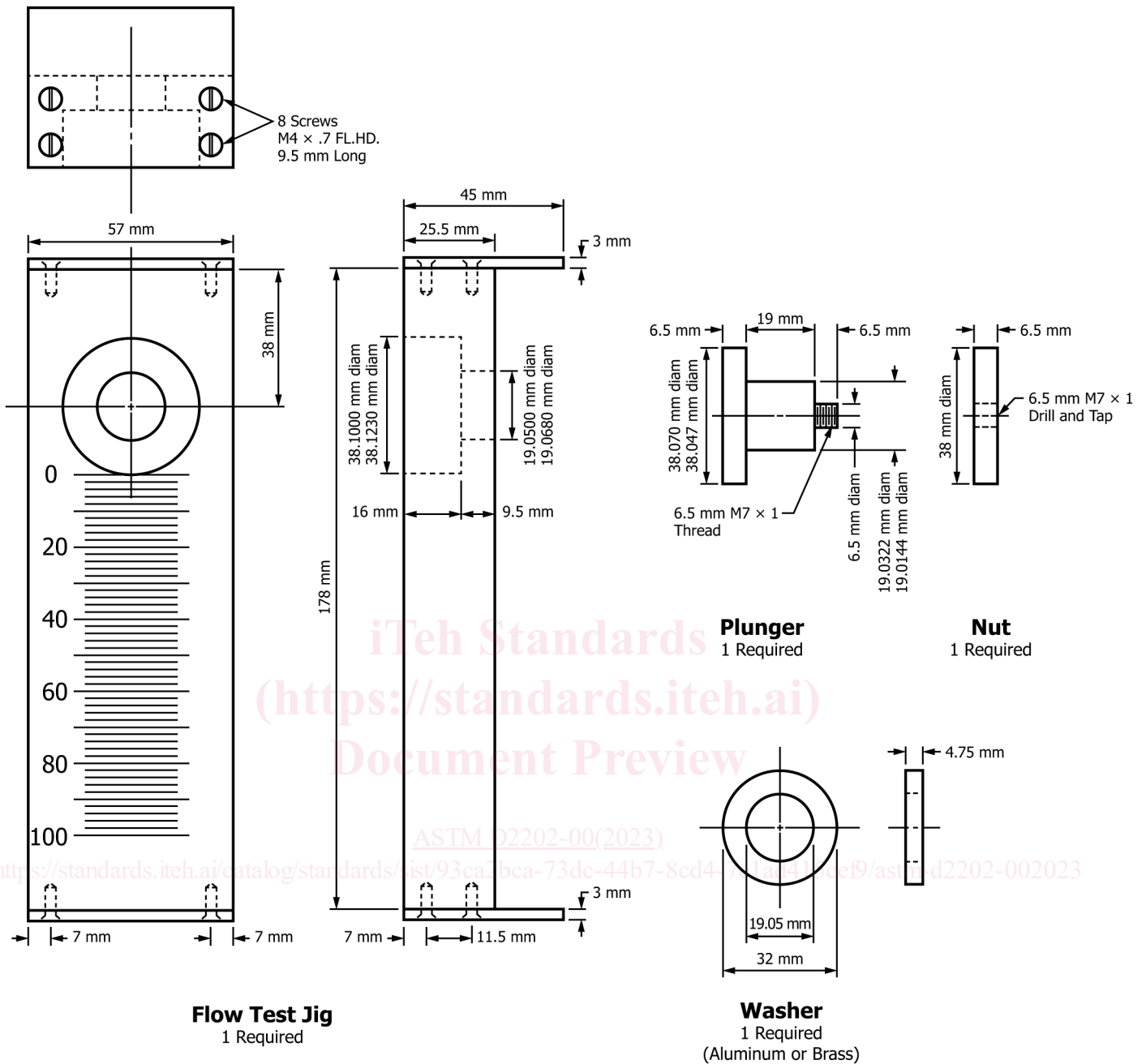

NOTE 1—For the Flow Test Jig, each scale division equals 2 mm.

NOTE 2—Material, aluminum alloy; finish, liquid hone; tolerances, (0.08 mm) unless otherwise indicated.

FIG. 1 Flow Test Jig (SI Units)

9.3 Carefully clean the area around the cavity with the plastic scraper and a cloth; then place the jig immediately on its end and advance the plunger gently to one half its maximum travel, or 4.75 mm (3/16 in.). This leaves a solid cylinder of caulking or sealant 38.1 mm (1 1/2 in.) in diameter and 4.75 mm (3/16 in.) thick, ready to flow down the face of the instrument.

9.4 Place the jig immediately in a vertical position on a level shelf in the oven and condition it for 30 min at 50 °C ± 2 °C (122 °F ± 3.6 °F), taking care to avoid any movement or vibration of the oven during this period.

9.5 At the conclusion of the 30-min period, take a reading, to the nearest 0.2 mm (0.01 in.) of the maximum point of flow of the compound.

9.6 Clean the jig and recondition it as specified in 8.1.

9.7 Repeat 9.1 – 9.5 with another specimen of sealant.

10. Report

10.1 Report the slump readings obtained in each of two tests for each specimen as well as the average value.

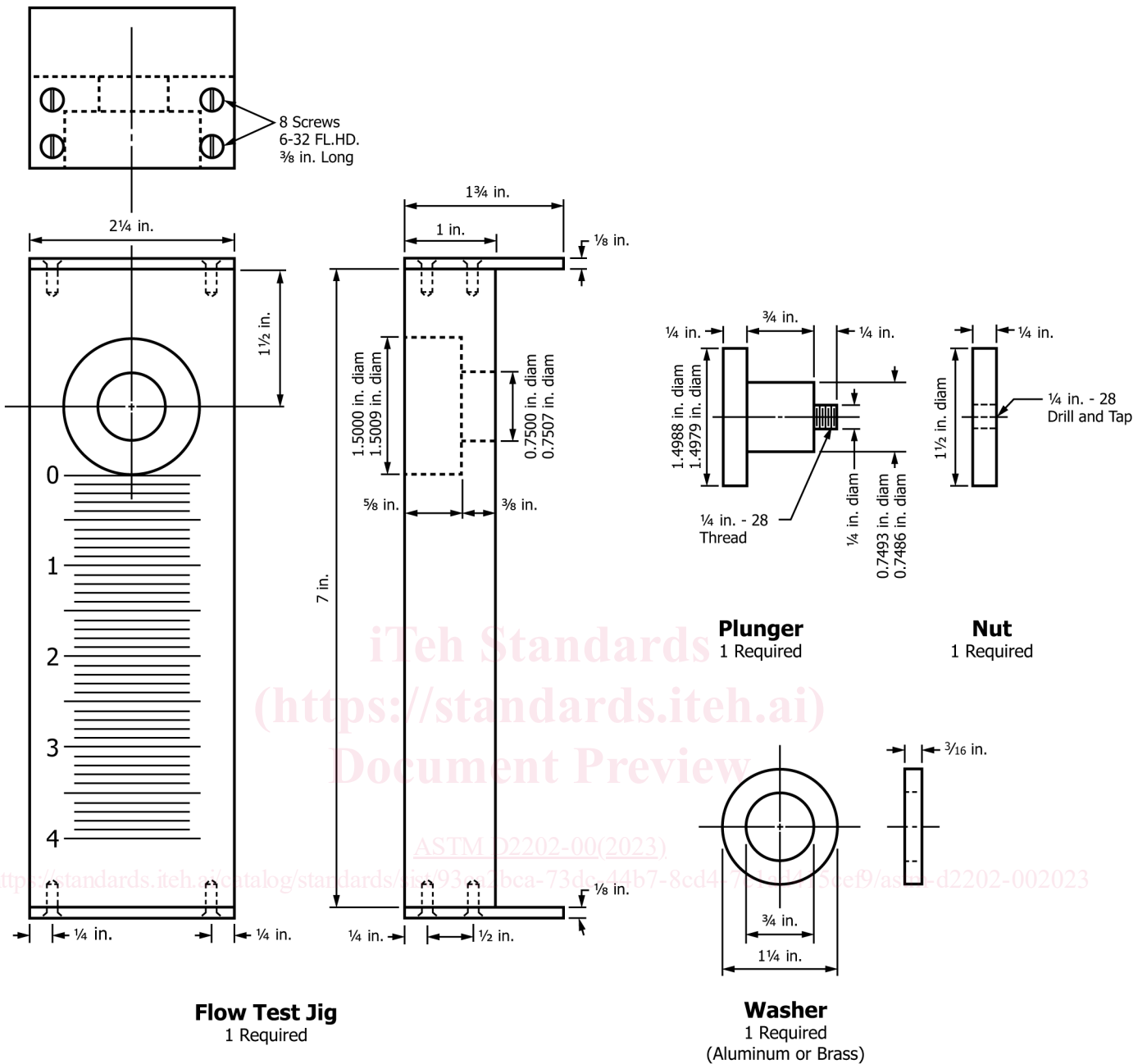

NOTE 1—For the Flow Test Jig, each scale division equals 1/10 in.

NOTE 2— Material, aluminum alloy; finish, liquid hone; tolerances, ±0.003 in. unless otherwise indicated.

FIG. 2 Flow Test Jig (Inch-Pound Units)

11. Precision and Bias⁴

11.1 *Precision*—The precision statements for this test method were obtained from two separate inter-laboratory tests. In one, five laboratories tested two (2) oil-based sealants, each in triplicate. The results are given in Table 1. In the other, four laboratories tested four (4) solvent release sealants, each in duplicate.

⁴ Supporting data are available from ASTM Headquarters. Request RR:C24-1026 and RR:C24-1039.

TABLE 1 Precision and Bias Data

Material	Average, mm	Estimated Standard Deviation (Within Laboratory)	Estimated Standard Deviation (Between Laboratory)	Repeatability (Internal)	Reproducibility
G 1	0.037	0.006	0.027	0.017	0.076
G 2	0.172	0.015	0.027	0.042	0.076

11.1.1 *Repeatability for Oil-Based Sealants*—At 95 % confidence, a variation of as much as 1.07 mm (0.042 in.) can