



Designation: D6619 – 00 (Reapproved 2023)

Standard Practice for Incorporating Pigments by High Speed Dispersion¹

This standard is issued under the fixed designation D6619; the number immediately following the designation indicates the year of original adoption or, in the case of revision, the year of last revision. A number in parentheses indicates the year of last reapproval. A superscript epsilon (ϵ) indicates an editorial change since the last revision or reapproval.

1. Scope

1.1 This practice covers the dispersion of pigments using a laboratory size high-speed impeller mill. It is similar in technical content to ISO 8780-3.

NOTE 1—This practice is restricted to mill bases of moderately high viscosity due to either high vehicle concentration or high pigment concentration, or both, which can produce high shear force. It is not intended to provide a means of formulating either pilot plant or full-scale mill base compositions (scaling up the process from laboratory equipment to factory mills is not simple).

1.2 *This standard does not purport to address all of the safety concerns, if any, associated with its use. It is the responsibility of the user of this standard to establish appropriate safety, health, and environmental practices and determine the applicability of regulatory limitations prior to use.*

1.3 *This international standard was developed in accordance with internationally recognized principles on standardization established in the Decision on Principles for the Development of International Standards, Guides and Recommendations issued by the World Trade Organization Technical Barriers to Trade (TBT) Committee.*

2. Referenced Documents

2.1 ISO Standards:

ISO 8780-3 Pigments and Extenders—Methods of Dispersion for Assessment of Dispersion Characteristics—Dispersion Using a High Speed Impeller Mill²

3. Significance and Use

3.1 High speed dispersion is a commonly used dispersion method in the coatings industry. For the purpose of this practice, “high speed” would normally be understood to be a range of RPM between 3 000 and 10 000. This practice provides a reference for its use, so that a producer and user can standardize on an incorporation technique. This will minimize

¹ This practice is under the jurisdiction of ASTM Committee D01 on Paint and Related Coatings, Materials, and Applications and is the direct responsibility of Subcommittee D01.24 on Physical Properties of Liquid Paints & Paint Materials.

Current edition approved June 1, 2023. Published July 2023. Originally approved in 2000. Last previous edition approved in 2016 as D6619 – 00 (2016). DOI: 10.1520/D6619-00R23.

² Available from American National Standards Institute (ANSI), 25 W. 43rd St., 4th Floor, New York, NY 10036, <http://www.ansi.org>.

differences in the millbase, and allow the interested parties to concentrate on the physical, chemical, or optical methods to be run.

4. Apparatus

4.1 *High-speed Impeller Mill*, consisting of a cylindrical vessel and a horizontal disk stirrer blade driven by a motor. A disk with a serrated edge is commonly used.

4.1.1 *Drive Unit*—The power rating of the drive unit shall be sufficient to maintain the peripheral speed of the disk at an agreed value. A reduced rotational speed shall be available for pre-mixing in accordance with 6.2. The motor of the drive unit shall be mounted on a stand together with the impeller shaft so that its height can be adjusted. There shall be a clamping device for the vessel at the foot of the stand, such that the impeller shaft is concentric with the vessel.

4.1.2 Disk and Vessel:

4.1.2.1 The diameters of the vessel and the disk shall be such that there is adequate clearance between the disk periphery and the walls of the vessel (see Fig. 1). If the disk is serrated, it shall be mounted so that the direction of movement of the serrations is such that the mill base flows in the directions shown in Fig. 1.

4.1.2.2 The degree of dispersion achieved will depend on the type of disk used. Fig. 1 shows only one type.

4.1.2.3 The type and diameter of the disk, the geometry of the vessel, and the speed of the disk shall be agreed upon and recorded in the test report.

NOTE 2—A vessel with a double wall to allow circulation of a liquid to control the temperature should be employed, if necessary. A lid with a central aperture may also be provided.

NOTE 3—The diameter of a vessel used in an industrial scale mill is normally two to three times the diameter of the impeller, or sometimes even greater. The vessel/disk geometry and the disk speed specified make allowance for the small diameter of a laboratory disk.

5. Vehicle System

5.1 The vehicle system shall be agreed upon between the interested parties. Agreement will be necessary on the vehicle, the solvent, the concentration of the vehicle in the solvent, as well as any critical temperature sensitivity or rheological properties (for example viscosity) of the vehicle system. The same batch of vehicle system shall be used for all tests in the same series.

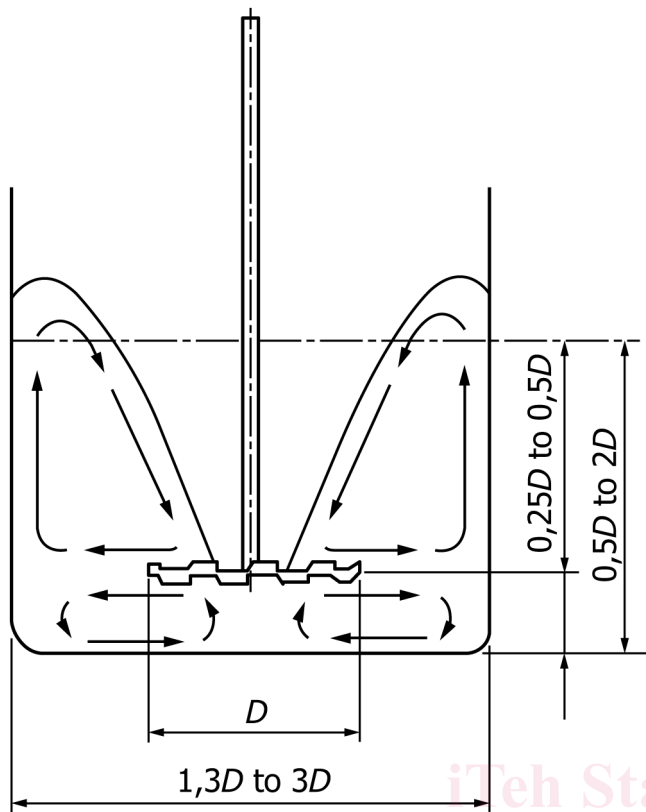

FIG. 1 Schematic Section of a Serrated-disk Impeller Mill

6. Mill Base Composition

6.1 General Requirements:

6.1.1 It is essential that the mill base assume a pattern in the form of a toroid (or doughnut). The concentrations of pigment and vehicle system required to give this pattern shall be determined by prior experiment.

6.1.2 In order to develop high shear in the mill, a high viscosity mill base is desirable. Thus, high pigment loadings or high vehicle solids, or both are usually recommended. The best combination of conditions depends upon the wetting properties of the vehicle system for the pigment being tested.

NOTE 4—It may be preferable to operate the laboratory mill under nonideal conditions so that differences between pigments are exaggerated. It has been found in practice that, with well-formulated mill bases, differences between easily dispersible pigments are minimized so that this practice is insensitive.

6.2 Determination of Mill Base Composition:

6.2.1 Add sufficient vehicle system to cover the impeller. Start the motor at the lowest speed. Make small additions of pigment (standard or test sample) and gradually increase the speed to that agreed. Observe the flow pattern throughout the whole operation and note how much pigment has been added when a toroid is first formed. Continue to add pigment until the

toroid starts to collapse, and again note the pigment mass added. Select a pigment concentration between these two points.

7. Procedure

7.1 Preliminaries:

7.1.1 Weigh the predetermined amount (see 6.2) of the vehicle system into the vessel. Weigh the predetermined amount (see 6.2) of the pigment (standard or test sample) into a separate container.

7.2 Pre-mixing:

7.2.1 If appropriate, bring the vessel and the vehicle system to the agreed temperature (see Section 5). Immerse the impeller to the agreed depth (see 4.1.2).

7.2.2 With the impeller running at a low speed, gradually incorporate the pigment within a period of 5 min. Add the pigment at such a rate that a small amount of unwetted pigment always remains visible on the surface of the millbase. Stop the motor, raise the impeller and, using a spatula, scrape off any pigment adhering to the impeller shaft and walls of the vessel into the mill base.

7.3 Dispersion:

7.3.1 Lower the impeller into the vessel to the agreed depth. Adjust the speed of rotation to that agreed. Confirm from the flow pattern that the mill base composition is satisfactory (see 6.1). If the flow pattern is unsatisfactory, adjust the amount of pigment or vehicle system in the vessel until the flow pattern is correct, and then, using the revised proportions, repeat the procedure from 7.1.

7.3.2 If desired, take test portions of the mill base after each of several (agreed) milling times as follows:

7.3.2.1 Stop the impeller after each of a number of agreed milling times (for example 4 min, 8 min, 16 min, 32 min) and take a small test portion. Measure the temperature of the mill base, if specified, and adjust to an agreed temperature before restarting the impeller.

7.4 Stabilization:

7.4.1 If necessary, for example if the mill base is not stable enough, stabilize each test portion after its removal from the mill base by adding, for example, more vehicle or special additives, or both. The procedure shall be agreed upon between the interested parties.

7.5 Deaeration:

7.5.1 If necessary, allow any air bubbles within the test portions to escape before proceeding to assess the dispersion. The means by which this is achieved, for example by allowing to stand for a few minutes, shall be agreed upon between the interested parties.

8. Keywords

8.1 high speed dispersion