



Designation: F543 – 23

# Standard Specification and Test Methods for Metallic Medical Bone Screws<sup>1</sup>

This standard is issued under the fixed designation F543; the number immediately following the designation indicates the year of original adoption or, in the case of revision, the year of last revision. A number in parentheses indicates the year of last reappraisal. A superscript epsilon ( $\epsilon$ ) indicates an editorial change since the last revision or reappraisal.

## 1. Scope

1.1 This specification provides requirements for materials, finish and marking, care and handling, and the acceptable dimensions and tolerances for metallic bone screws that are implanted into bone. The dimensions and tolerances in this specification are applicable only to metallic bone screws described in this specification.

1.2 This specification provides performance considerations and standard test methods for measuring mechanical properties in torsion of metallic bone screws that are implanted into bone. These test methods may also be applicable to other screws besides those whose dimensions and tolerances are specified here. The following annexes are included:

1.2.1 **Annex A1**—Test Method for Determining the Torsional Properties of Metallic Bone Screws.

1.2.2 **Annex A2**—Test Method for Driving Torque of Medical Bone Screws.

1.2.3 **Annex A3**—Test Method for Determining the Axial Pullout Load of Medical Bone Screws.

1.2.4 **Annex A4**—Test Method for Determining the Self-Tapping Performance of Self-Tapping Medical Bone Screws.

1.2.5 **Annex A5**—Specifications for Type HA and Type HB Metallic Bone Screws.

1.2.6 **Annex A6**—Specifications for Type HC and Type HD Metallic Bone Screws.

1.2.7 **Annex A7**—Specifications for Metallic Bone Screw Drive Connections.

1.3 This specification is based, in part, upon ISO 5835, ISO 6475, and ISO 9268.

1.4 The values stated in SI units are to be regarded as standard. No other units of measurement are included in this standard.

1.5 Multiple test methods are included in this standard. However, the user is not necessarily obligated to test using all of the described methods. Instead, the user should only select, with justification, test methods that are appropriate for a

particular device design. This may only be a subset of the herein described test methods.

1.6 This standard may involve the use of hazardous materials, operations, and equipment. *This standard does not purport to address all of the safety concerns, if any, associated with its use. It is the responsibility of the user of this standard to establish appropriate safety, health, and environmental practices and determine the applicability of regulatory limitations prior to use.*

1.7 *This international standard was developed in accordance with internationally recognized principles on standardization established in the Decision on Principles for the Development of International Standards, Guides and Recommendations issued by the World Trade Organization Technical Barriers to Trade (TBT) Committee.*

## 2. Referenced Documents

2.1 *ASTM Standards:*<sup>2</sup>

**E4** Practices for Force Calibration and Verification of Testing Machines

**E6** Terminology Relating to Methods of Mechanical Testing

**E8/E8M** Test Methods for Tension Testing of Metallic Materials

**E122** Practice for Calculating Sample Size to Estimate, With Specified Precision, the Average for a Characteristic of a Lot or Process

**F67** Specification for Unalloyed Titanium, for Surgical Implant Applications (UNS R50250, UNS R50400, UNS R50550, UNS R50700)

**F86** Practice for Surface Preparation and Marking of Metallic Surgical Implants

**F116** Specification for Medical Screwdriver Bits

**F136** Specification for Wrought Titanium-6Aluminum-4Vanadium ELI (Extra Low Interstitial) Alloy for Surgical Implant Applications (UNS R56401)

**F138** Specification for Wrought 18Chromium-14Nickel-2.5Molybdenum Stainless Steel Bar and Wire for Surgical Implants (UNS S31673)

<sup>1</sup> This specification is under the jurisdiction of ASTM Committee F04 on Medical and Surgical Materials and Devices and is the direct responsibility of Subcommittee F04.21 on Osteosynthesis.

Current edition approved June 1, 2023. Published July 2023. Originally approved in 1977. Last previous edition approved in 2017 as F543 – 17. DOI: 10.1520/F0543-23.

<sup>2</sup> For referenced ASTM standards, visit the ASTM website, [www.astm.org](http://www.astm.org), or contact ASTM Customer Service at [service@astm.org](mailto:service@astm.org). For *Annual Book of ASTM Standards* volume information, refer to the standard's Document Summary page on the ASTM website.

- F565 Practice for Care and Handling of Orthopedic Implants and Instruments
- F620 Specification for Titanium Alloy Forgings for Surgical Implants in the Alpha Plus Beta Condition
- F799 Specification for Cobalt-28 Chromium-6 Molybdenum Alloy Forgings for Surgical Implants (UNS R31537, R31538, R31539)
- F983 Practice for Permanent Marking of Orthopaedic Implant Components
- F1295 Specification for Wrought Titanium-6Aluminum-7Niobium Alloy for Surgical Implant Applications (UNS R56700)
- F1314 Specification for Wrought Nitrogen Strengthened 22 Chromium-13 Nickel-5 Manganese-2.5 Molybdenum Stainless Steel Alloy Bar and Wire for Surgical Implants (UNS S20910)
- F1472 Specification for Wrought Titanium-6Aluminum-4Vanadium Alloy for Surgical Implant Applications (UNS R56400)
- F1537 Specification for Wrought Cobalt-28Chromium-6Molybdenum Alloys for Surgical Implants (UNS R31537, UNS R31538, and UNS R31539)
- F1586 Specification for Wrought Nitrogen Strengthened 21Chromium-10Nickel-3Manganese-2.5Molybdenum Stainless Steel Alloy Bar for Surgical Implants (UNS S31675)
- F1713 Specification for Wrought Titanium-13Niobium-13Zirconium Alloy for Surgical Implant Applications (UNS R58130) (Withdrawn 0)<sup>3</sup>
- F1813 Specification for Wrought Titanium-12Molybdenum-6Zirconium-2Iron Alloy for Surgical Implant (UNS R58120)
- F1839 Specification for Rigid Polyurethane Foam for Use as a Standard Material for Testing Orthopaedic Devices and Instruments
- F2066 Specification for Wrought Titanium-15 Molybdenum Alloy for Surgical Implant Applications (UNS R58150)
- F2503 Practice for Marking Medical Devices and Other Items for Safety in the Magnetic Resonance Environment

2.2 ISO Standards:<sup>4</sup>

- 5835 Implants for Surgery—Metal Bone Screws with Hexagonal Driver Connection, Spherical Under Surface of Head, Asymmetrical Thread—Dimensions
- 6475 Implants for Surgery—Metal Bone Screws with Asymmetrical Thread and Spherical Under-Surface—Mechanical Requirements and Test Methods
- 8319-1 Orthopaedic Instruments—Drive connections—Part 1: Keys for use with hexagon socket heads
- 8319-2 Orthopaedic Instruments—Drive connections—Part 2: Screwdrivers for single slot head screws, screws with cruciate and cross-cessed head screws
- 9268 Implants for Surgery—Metal Bone Screws with Conical Under-Surface of Head—Dimensions

10664 Hexalobular Internal Driving Feature for Bolts and Screws

3. Terminology

3.1 Definitions—Some of the terms defined in this section are shown in Fig. 1.

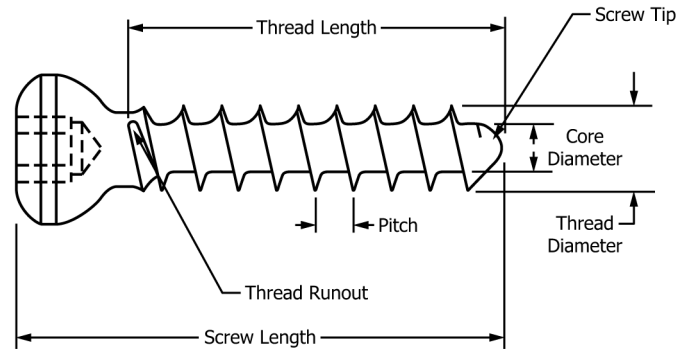

FIG. 1 Schematic of Screw Terms

3.1.1 *axial pullout load*—the tensile force required to fail or remove a bone screw from a material into which the screw has been inserted.

3.1.2 *breaking angle*—angle of rotation when the screw fails in torsion as demonstrated by a rapid decrease in the indicated torque.

3.1.3 *buttress thread*—an asymmetrical thread profile characterized by a pressure flank which is nearly perpendicular to the screw axis.

3.1.4 *cancellous screw*—a screw designed primarily to gain purchase into cancellous bone. Cancellous screws typically have an HB (see 4.1.2) thread and may or may not be fully threaded.

3.1.5 *cortical screw*—a screw designed primarily to gain biocortical purchase into cortical bone. Cortical screws typically have a HA (see 4.1.1) thread and are fully threaded.

3.1.6 *core diameter*—the smallest diameter of the threaded portion of the screw measured at the thread root. This is also known as the minor diameter or root diameter.

3.1.7 *gage length*—the distance between the holding device (for example, a split collet) and the underside of the screw head.

3.1.8 *grip length*—the length of threads held fast in the split collet or other holding mechanism.

3.1.9 *insertion depth*—the threaded length as inserted into the test block.

3.1.10 *insertion torque*—the amount of torque required to overcome the frictional force between the screw and the material used for testing while driving the screw into the material.

3.1.11 *maximum torque* (N-m)—the largest value of torque recorded during the period of rotation before screw failure in torsional shear when tested in accordance with Annex A1.

<sup>3</sup> The last approved version of this historical standard is referenced on www.astm.org.

<sup>4</sup> Available from American National Standards Institute, 25 W. 43rd St., 4th Floor, New York, NY 10036.

3.1.12 *nontapping screw*—a screw that has a tip that does not contain a flute. Nontapping screws usually require a tap to be inserted into the pilot hole before the insertion of the screw, when used in moderate or hard bone.

3.1.13 *partially threaded screw*—a screw whose threaded portion does not extend fully from the screw point to the screw head but instead has a smooth shaft running between the head and threads.

3.1.14 *pilot hole*—the hole drilled into the bone into which the screw tip is inserted. The pilot hole is normally slightly larger than the screw's core diameter. However, if the screw is to be used to provide compression across a fracture, a portion of the pilot hole may be larger to allow for a clearance fit.

3.1.15 *pitch*—the length between the thread crests.

3.1.16 *removal torque*—the amount of torque required to overcome the frictional force between the screw and the material used for testing while removing the screw from the material (for example, counterclockwise rotation for right-hand thread).

3.1.17 *screw head*—the end of the screw which is opposite of the tip and to which the means of inserting the screw is coupled.

3.1.18 *screw length*—the overall length of the screw measured from the screw head to the screw tip.

3.1.19 *screw thread*—a helical groove on a cylindrical or conical surface. The projecting helical ridge thus formed is called a screw thread, consisting of peaks (crests) and valleys (roots).

3.1.20 *self-tapping force (N)*—the amount of axial force required to engage the self-tapping features of self-tapping style screws when tested in accordance with [Annex A4](#).

3.1.21 *self-tapping screw*—a screw that has any number of flutes at its tip which are intended to cut the screw's thread form into the bone upon insertion.

3.1.22 *size*—an identification of a screw based on its nominal thread diameter, as defined in [Section 6](#).

3.1.23 *solid core*—a screw that does not contain a cannulation along its longitudinal axis.

3.1.24 *thread diameter*—the largest diameter of the threaded portion of the screw measured over the thread crests. This is also known as the major diameter.

3.1.25 *thread length*—the length of the threaded portion of the screw, measured from the thread runout to the screw tip.

3.1.26 *thread runout*—the intersection of the screw thread with either the screw shaft or screw head.

3.1.27 *torsional yield strength (N-m)*—the point at which the screw reaches its proportional limit when tested in accordance with [Annex A1](#). This will be determined by the offset method. A 2° offset value shall be used.

#### 4. Classification

4.1 There are a large variety of medical bone screws currently in use. They may be classified by the definitions provided in [Section 3](#). This specification currently includes information that defines the following types of screws:

4.1.1 *Type HA*—Spherical undersurface of head, shallow, asymmetrical buttress thread, and deep screw head.

4.1.2 *Type HB*—Spherical undersurface of head, deep, asymmetrical buttress thread, and shallow screw head.

4.1.3 *Type HC*—Conical undersurface of head, symmetrical thread.

4.1.4 *Type HD*—Conical undersurface of head, asymmetrical thread.

#### 5. Material

5.1 Screws shall be fabricated from a metallic material intended for surgical implant applications, and meeting the requirements for an ASTM medical material. In addition, the materials shall be biocompatible for the intended application.

#### 6. Dimensions and Tolerances

6.1 There are many types of metallic bone screw designs available, so a complete list of dimensions and tolerances for all screws covered by this specification is unfeasible. However, this specification does provide required dimensions and tolerances for four types of screws as classified in [4.1](#). Screws conforming to this specification, and designated HA, HB, HC, or HD screws, shall be fabricated in accordance with the dimensions and tolerances described in [Annex A5](#) and [Annex A6](#).

#### 7. Finish and Marking

7.1 The screw shall be free from nicks, dents, burrs, and scratches when examined in accordance with [Practice F86](#).

7.2 When size permits, the following information should be legibly marked on the head of the screw (in order of preference):

7.2.1 Manufacturer's name or logo,

7.2.2 *Screw Size*—If a screw is manufactured in accordance with ASTM or ISO specifications, the ASTM or ISO designation should be provided,

7.2.3 Material,

7.2.4 Catalog number, and

7.2.5 Manufacturing lot number.

7.3 Screws shall be marked in accordance with [Practice F983](#), unless otherwise specified in [7.2](#), in a manner such that the mechanical integrity of the screw is not compromised.

#### 8. Care and Handling

8.1 Screws should be cared for and handled in accordance with [Practice F565](#), as appropriate.

8.2 Consider [Practice F2503](#) to identify potential hazards produced by interactions between the device and the MR environment and for terms that may be used to label the device for safety in the MR environment.

#### 9. Driving Instruments

9.1 A variety of screwdrivers for the insertion and removal of bone screws exist. The classification and dimensions for various screw-drive recesses currently used in the medical industry are documented in [Annex A7](#). Specification [F116](#)

provides related dimensional information for several types of medical screwdrivers.

9.2 Screws conforming to this specification, and designated HA, HB, HC, or HD screws, shall be manufactured with drive recesses that conform to the requirements specified in [Annex A5](#) and [Annex A6](#).

## 10. Performance Considerations and Test Methods

10.1 The following properties may be important when determining the suitability of a screw for a particular application. However, the test methods referenced as follows may not be appropriate for all types of implant applications. The user is cautioned to consider the appropriateness of the test methods in view of the devices being tested and their potential application.

10.1.1 *Torsional Strength*—This test method is an important parameter to prevent screw breakage during insertion or removal. The torsional strength shall be determined using the test methods described in [Annex A1](#).

10.1.2 *Breaking Angle*—This test method provides a measure of the ductility of the screw when undergoing a torsional moment. A screw with a greater breaking angle may provide an earlier tactile warning to the surgeon that the screw is reaching its maximum torsional strength. The breaking angle shall be determined using the test methods described in [Annex A1](#).

10.1.3 *Axial Pullout Load*—This test method may be an important parameter if the screw is subjected to axial tensile forces, or if the screw is fixed into poor quality or osteoporotic

bone. The pullout load may be determined using the test methods described in [Annex A3](#).

10.1.4 *Insertion Torque*—This test method may be an important parameter to avoid failure of the screw during insertion and to ensure that the screw may be easily inserted by the surgeon. The insertion torque should be much less than torsional yield strength of the screw and of the appropriate screwdriver bit. The insertion torque may be determined using the test methods described in [Annex A2](#).

10.1.5 *Removal Torque*—This test method may be an important parameter to avoid failure of the screw during removal and to ensure that the screw may be easily removed by the surgeon. The removal torque should be much less than torsional yield strength of the screw and of the appropriate screwdriver bit. The removal torque may be determined using the test methods described in [Annex A2](#).

10.1.6 *Self-Tapping Force*—This test method may be an important parameter to ensure that the screw may be easily inserted by the surgeon, particularly if the screw is fixed in poor quality or osteoporotic bone. The self-tapping force may be determined using the test method described in [Annex A4](#).

## 11. Performance Requirements

11.1 Screws shall meet the mechanical performance requirements specified in its associated specification annex.

## 12. Keywords

12.1 bone screw; dimensions; insertion; performance requirements; pullout; static; test methods; torsion

# Document Preview

## ANNEXES

### (Mandatory Information)

<https://standards.iteh.ai/catalog/standards/sist/bd5870db-b90-4bdb-93e4-29d831b0ec38/astm-f543-23>

## A1. TEST METHOD FOR DETERMINING THE TORSIONAL PROPERTIES OF METALLIC BONE SCREWS

### A1.1 Significance and Use

A1.1.1 This test method is used to measure the torsional yield strength, maximum torque, and breaking angle of the bone screw under standard conditions. The results obtained in this test method are not intended to predict the torque encountered while inserting or removing a bone screw in human or animal bone. This test method is intended only to measure the uniformity of the product tested or to compare the mechanical properties of different, yet similarly sized, products.

### A1.2 Apparatus

A1.2.1 *Testing Fixture*—The torsion testing apparatus that is to be used for applying the required torque to the specimen shall be calibrated for the range of torques and rotational displacements used in the determination.<sup>5</sup> A suitable testing

fixture for the torsional yield strength maximum torque-breaking angle test is illustrated in [Fig. A1.1](#).

A1.2.1.1 *Test Speed*—The torsional force shall be applied at a constant rate of 1 to 5 r/min.

A1.2.1.2 *Torque Transducer*—A transducer to translate the applied torque into an electrical signal amenable to continuous recording, calibrated over the range of torques, both in the clockwise and counterclockwise rotation, to be encountered in the test method, shall be provided.

A1.2.1.3 *Torsional Displacement Transducer*—A transducer to translate the angle of twist into an electrical signal amenable to continuous recording, calibrated over the range of angles to be encountered in the test and an accuracy of  $\pm 0.3^\circ$ , both in the clockwise and counterclockwise rotation, shall be provided.

A1.2.1.4 *Specimen Holder*—A mechanical device to clamp onto the bone screw to prevent its rotation while being stressed without significantly damaging its mechanical integrity shall be provided. One such method is to insert a threaded stopper into the opposite side of a test block. The test block for this holding

<sup>5</sup> At the time that this specification was approved, no standard test method for the verification of torsion machines or transducers has been accepted. The user is urged to review Terminology [E6](#) and Test Methods [E8/E8M](#) for general guidance.

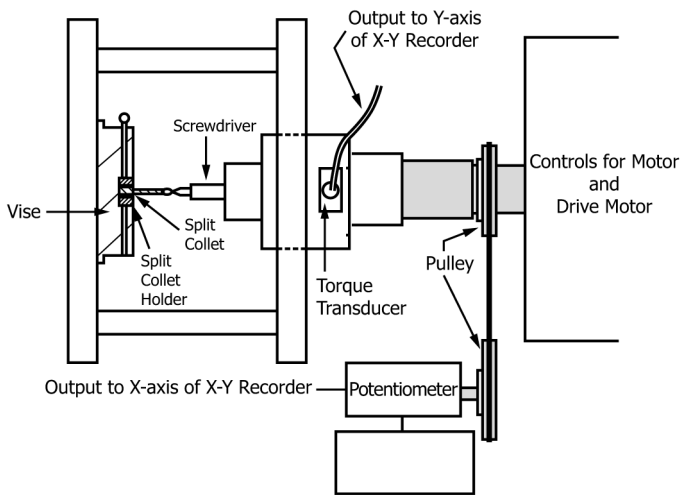

FIG. A1.1 Test Apparatus for Determination of Torsional Breaking Force and Breaking Angle

appropriate. Place the split collet in the collet holder. Clamp the split collet and holder in the vise. The clamping force of the vise should be sufficient to prevent rotation of the screw or the split collet. Drive the specimen in the direction of insertion, using an appropriate size and configured screwdriver bit, by applying a torsional force. If an axial load is required to maintain the screwdriver bit in the screw head, its value should be noted. The torque wrench shall be driven at a rate of 1 to 5 revolutions/min (r/min).

NOTE A1.1—The simultaneous use of two chart recorders may simplify the ability to measure torsional yield strength accurately by the offset method. One chart recorder with an angular displacement scale or sensitivity of 50°/cm is convenient for measuring maximum torque and breaking angle. A second chart recorder with an angular displacement scale or sensitivity of 10°/cm or less is suggested to provide accurate offset measurement capability for measuring a 2° angular displacement. Alternatively, one chart recorder and a digital storage oscilloscope may be used.

A1.3.3 The torsional yield strength will be determined by the offset method (Fig. A1.2), using the torque versus angle of rotation curve produced in A1.3.1 and A1.3.2.

A1.3.3.1 On the torque versus angle of rotation curve, locate Point *m* equal to a rotation of 2°. Draw *mn* parallel to *OA*, and locate *b*, the intersection of *mn* with the torque versus angle of rotation curve. Torque *B* is defined as the torsional yield strength.

A1.3.3.2 The maximum torque is determined by the largest value of torque on the torque versus angle of rotation curve.

A1.3.3.3 The breaking angle is determined from the torque versus angle plot shown in Fig. A1.3. The breaking angle is defined as the point at which the torque portion of the curve demonstrates its most rapid descent (negative slope) to total failure. The breaking angle (B.A.) is determined as the intersection of the two tangents (*D* and *E*) shown in Fig. A1.3. Line *E* is a tangent to the horizontal portion of the curve which represents maximum torque. Line *D* is drawn at the curve's most rapid descent. The intersection of these two lines is the breaking angle (B.A.) and is recorded to the nearest 10°.

mechanism will accommodate the insertion of a threaded stopper on the other side of the test block. The threaded stopper will prevent the screw from being completely inserted into the test block and will allow the torsional strength of the screw to be measured. This holder will be modified according to the size of the testing specimen so that the gage length of the specimen will be as outlined in A1.3.1.

A1.2.1.5 Recorder—The data recorder shall be suitable to continuously record torque versus angle of rotation, calibrated in units of newton-meters for torque and degrees for angle of rotation. The value of torque shall have a resolution of 5 % of torsional yield strength. The angular displacement scale shall have a minimum sensitivity so as to enable an accurate offset measurement capability for a 2° angular displacement (see A1.3.3).

A1.2.2 Test Specimen—The test specimen shall be a completely fabricated and finished bone screw.

### A1.3 Procedure

A1.3.1 Torsional Yield Strength, Maximum Torque, and Breaking Angle—Place the specimen in the holding device so that five threads below the head of the screw are exposed outside the holding device (for example, split collet, and so forth). If the test specimen cannot accommodate this setup because the screw is too small or is partially threaded, alternate procedures may be used. For fully threaded screws that are too small, the gage length of the specimen should represent 20 % of the threaded portion of the test specimen. For partially threaded screws, a large enough portion of the screw thread should be gripped to firmly secure the screw so that it does not rotate when under torsional load. There are no specific requirements on the gage length or the grip length in this case; however, at least one full thread shall be exposed, if possible. Since the gage length and grip length can vary for these screws, the only requirement is that both be reported.

A1.3.2 The gage length or grip length should be kept the same length for test screws of similar design. If a split collet and collet holder are used, the following test method is

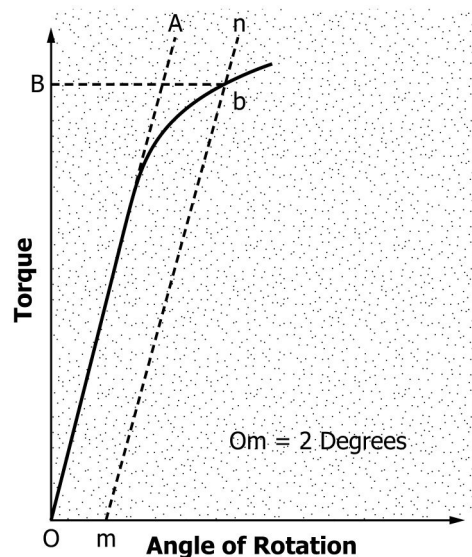

FIG. A1.2 Typical Torque versus Angle of Rotation Curve

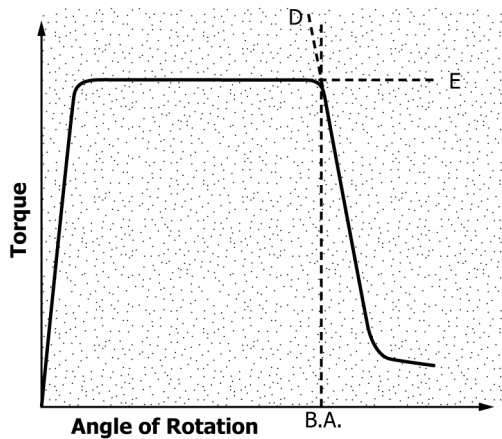

FIG. A1.3 Typical Plot of Torque versus Torsion Angle

head and shank (unthreaded portion of the screw excluding the head) length, and type of screw point.

A1.4.1.2 Screw chemical composition.

A1.4.1.3 Surface finish.

A1.4.1.4 Gage length.

A1.4.1.5 Torsional yield strength.

A1.4.1.6 Maximum torque.

A1.4.1.7 Breaking angle.

A1.4.1.8 Torque versus angle of rotation plot.

A1.4.1.9 The size of the exposed portion of the screwdriver (that is, the length and diameter relative to the tested screw) or the angular deformation of the screwdriver assembly at maximum torque.

A1.4.1.10 *Grip Length*—Does not have to be reported for a fully threaded screw of ASTM or ISO specification whose overall length is given.

A1.4.1.11 *Fracture Location*—The location can be specified by listing the number of threads below the head at which the screw fails or by measuring the distance below the head to the approximate fracture point.

### A1.5 Precision and Bias

A1.5.1 Data establishing the precision and bias to be expected from this test method have not yet been obtained.

## A1.4 Report

A1.4.1 Report the following information for each specimen tested:

A1.4.1.1 *Screw Identification*—Reference any applicable ASTM or ISO specification that may apply to the specimen. If specifications do not exist, provide head form, thread form, major and minor diameter, thread pitch, overall screw length,

## A2. TEST METHOD FOR DRIVING TORQUE OF MEDICAL BONE SCREWS

### A2.1 Significance and Use

A2.1.1 This test method is used to measure the torque required to drive a bone screw into a standard material. The results obtained in this test method bear no direct correlation to the insertion torque required to insert the subject bone screw in human or animal bone. This test method should be used only for the purpose of maintaining the uniformity of the product tested.

### A2.2 Apparatus

A2.2.1 *Testing Fixture*—A suitable test fixture as shown in Fig. A2.1 may be used for the insertion-removal torque tests.<sup>5</sup> This fixture shall incorporate the test block material that conforms to Specification F1839, test block clamp, drill bushing (if necessary to maintain alignment), and bushing support (if drill bushing is used).

A2.2.1.1 *Torque Transducer*—A transducer to convert the applied torque into an electrical signal amenable to continuous recording, calibrated over the range of torques, in both the clockwise and counterclockwise rotation, to be encountered in the test shall be provided.

A2.2.1.2 *Torsional Displacement Transducer*—A transducer to translate the angle of twist into an electrical signal amenable to continuous recording, calibrated in a manner similar to

Practices E4 over the range of angles to be encountered in the test to an accuracy of  $\pm 0.3^\circ$ , in both the clockwise and counterclockwise rotation, shall be provided.

A2.2.1.3 *Data Recorder*—The data recorder shall be suitable to record torque versus angle of rotation continuously, calibrated in units of newton-meters for torque and degrees for angle of rotation. The value of torque shall have a resolution of 10 % of the maximum measured torque. The angular displacement scale shall have sensitivity such that at least four revolutions can be recorded and displayed.

A2.2.1.4 *Test Block Clamp*—A clamp or holding device shall be incorporated into the testing fixture. This clamp shall maintain the drilled pilot hole in the test block in line with the test specimen.

A2.2.1.5 *Test Specimen*—The test specimen shall be a completely fabricated, finished bone screw of sufficient length to traverse the test block.

A2.2.1.6 *Test Block*—The test block shall be fabricated from a uniform material that conforms to Specification F1839. The choice of appropriate foam density for this test is at the discretion of the user. See Section 8.6.2 of Specification F1839 for additional information. To accommodate the requirements of the pilot hole as described in A2.2.1.7, the smallest

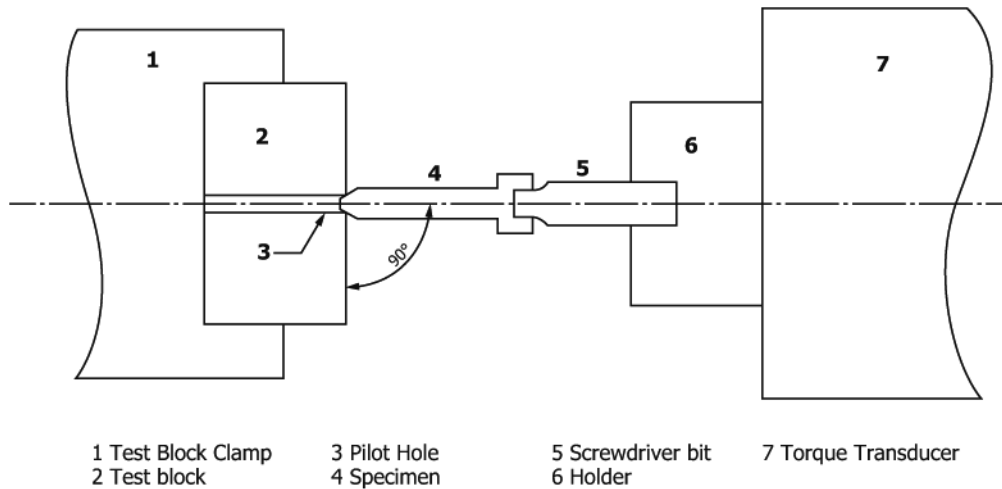

**FIG. A2.1 Schematic of Test Apparatus for Driving Force**

dimension of the test block's surface shall be greater than 5× the diameter of the screw under test. The top and bottom surfaces shall be flat, smooth, and parallel as required to ensure that the test block will be supported in the fixture with the top surface at an angle of 90° to the centerline of the test specimen. The test block thickness shall be not less than 1.25× the intended insertion depth.

**A2.2.1.7 Pilot Holes in Test Block**—Pilot holes shall be drilled in the test block for insertion of the test specimen for test specimens that require pilot holes. The drill size used shall be that specified by the screw manufacturer for the size screw being tested. If specified by the screw manufacturer, the specified sized tap could be used to tap the pilot hole before testing. The holes shall be drilled perpendicular to the top surface of the test block. The holes shall be drilled straight and true, free of taper, bell mouth, or barrel shape. If there are multiple holes in one test block, the pilot holes shall be spaced sufficiently far away from test block edges so that testing does not deform the test block edges. Spacing should have a minimum distance of 5× the diameter of the screw. When the test block is inserted into the test fixture (Fig. A2.1), the pilot hole, screw, and screwdriver shall be on the same axis.

**A2.2.1.8 Screwdriver Bit**—A screwdriver bit shall be used to insert or remove bone screws on test blocks. An off-the-shelf screwdriver bit may be used in lieu of a screwdriver bit that is representative of the instruments indicated to be used with the screw, only if the screwdriver bit is not a source or cause of failure during insertion or removal of the bone screw.

### A2.3 Sampling

**A2.3.1** Representative random samples may be taken from each lot or processing quantity in accordance with Practice E122. Minimum sample size is  $n = 5$ .

### A2.4 Procedure

**A2.4.1 Insertion Torque**—Place the specimen in the test fixture as illustrated in Fig. A2.1. Zero the load where the tip of the screw is not in contact with the test block. Zero the displacement where the tip of the screw is flush with the test surface of the block. Drive the specimen into the test block,

using the appropriate screwdriver bit, by applying a torsional force at a rate of 1 to 5 r/min (3 rpm is recommended) to the head of the specimen with the machine actuator. Values should be reported in newton-meters. The exposed length of the screwdriver bit shall be equal to 20 mm, or less if justified (see X1.10). For fully threaded screws, 20 mm of the thread length shall be inserted into the test block. For fully threaded screws with threaded lengths equal or less than 20 mm, 100 % of the threaded length of the screw shall be inserted, except by one thread below the screw's head, which may be left exposed. For partially threaded screws, 20 mm or 100 % of the threaded length of the screw shall be inserted into the test block. For comparison between partially threaded screws with different thread lengths, they should all be inserted to the same depth. The insertion torque shall be the maximum reading recorded during the insertion of the specimen.

**A2.4.2 Removal Torque**—The removal torque measurement is optional. If it is conducted, it shall be measured by reversing the direction of rotation and recording the torque during the removal of the screw from the test block. The removal torque shall be the maximum reading recorded during the removal of the specimen.

**A2.4.3 Axial Load for Insertion and Removal Torque Measurements**—An axial load of 11.5 N or less should be used to maintain the screwdriver bit in the screw head during both the insertion and removal procedures. If a larger axial load is applied, this load shall be recorded on the report form. This load may be measured by any appropriate method. Torque values should be reported in newton-meters.

### A2.5 Report

**A2.5.1** The report shall include the following for each specimen tested. (All standards units for reporting shall be in SI units.)

**A2.5.1.1 Screw Identification**—Reference any applicable ASTM or ISO standard specification that may apply to the specimen. If specifications do not exist, provide head form, thread form, major and minor diameter, thread pitch, overall

screw length, head and shank (unthreaded portion of the screw excluding the head) length, and type of screw point.

A2.5.1.2 Screw material.

A2.5.1.3 Screw surface finish.

A2.5.1.4 Insertion torque.

A2.5.1.4.1 Axial load applied during insertion.

A2.5.1.4.2 Insertion depth (may be calculated or measured).

A2.5.1.4.3 Specification of whether the pilot holes were or were not pretapped, if pretapped, specifications of the tap size, tap diameter, and tap depth shall be reported.

A2.5.1.4.4 Insertion test speed if different from specified in A2.4.1.

A2.5.1.5 Removal torque, if applicable.

A2.5.1.5.1 Axial load applied during removal.

A2.5.1.5.2 Removal test speed if different from specified for insertion torque in A2.4.1.

A2.5.1.6 *Test Block Material Description*—Specification F1839 grade. For test block material that does not conform to Specification F1839, provide the following information:

A2.5.1.6.1 Trade name.

A2.5.1.6.2 Composition.

A2.5.1.6.3 Density.

A2.5.1.6.4 Tensile strength.

A2.5.1.6.5 Compression strength.

A2.5.1.6.6 Shear strength.

A2.5.1.7 *Test Machine*—List relevant information about the test machine and provide the calibrated range of the load cell and torque wrench used.

A2.5.1.8 *Test Environment*—For example, air, room temperature, and other relevant environment information.

A2.5.1.9 Deviations from this test method, including description and rationale/justification.

## A2.6 Precision and Bias

A2.6.1 Data establishing the precision and accuracy to be expected from this test method have not yet been obtained.

## A3. TEST METHOD FOR DETERMINING THE AXIAL PULLOUT LOAD OF MEDICAL BONE SCREWS

### A3.1 Significance and Use

A3.1.1 This test method is used to measure the axial tensile force required to fail or remove a bone screw from a defined material. The results obtained in this test method are not intended to predict the force required to remove the subject bone screw from human or animal bone. This test method is intended only to measure the uniformity of the products tested or to compare the pullout load of different products.

A3.1.2 This test method may not be appropriate for all types of implant applications. The user is cautioned to consider the appropriateness of the method in view of the materials being tested and their potential application.

### A3.2 Apparatus

A3.2.1 *Test Fixture*—Machines used for testing the axial pullout load of screws shall conform to the requirements of Practices E4. A suitable test fixture as shown in Fig. A3.1 may be used. This fixture shall incorporate the test block material which conforms to Specification F1839. Drill bushing and bushing support are optional. The test block clamp should have a minimum grip span of 20 mm or five times the major diameter of the bone screw with the screw centered between the grips, whichever length is higher.

A3.2.2 *Test Block*—The test block shall be fabricated from a uniform material that conforms to Specification F1839. The choice of appropriate foam density for this test is at the discretion of the user. See Section 8.6.2 of Specification F1839 for additional information. The top and bottom surfaces shall be flat, smooth, and parallel as required to ensure that the test block will be supported in the fixture with the top surface perpendicular to the centerline of the test specimen. Screws inserted during testing shall be at minimum distance of 5× the

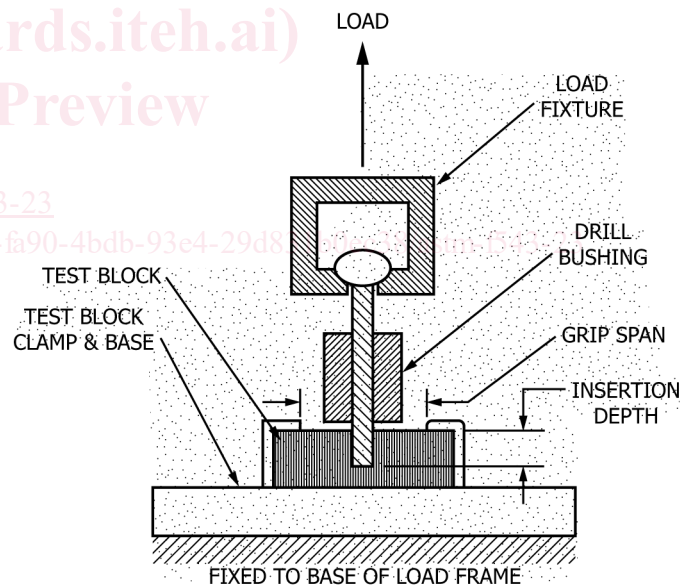

FIG. A3.1 Schematic of Test Apparatus for Pullout Load (when drill bushing is used)

diameter of the screw from adjacent screws or the edges of the foam. The depth of the test block shall not be less than 1.25× the intended insertion depth.

A3.2.3 *Data Recorder*—The data recorder shall be suitable to continuously record load versus displacement.

A3.2.4 *Load Frame*—Machines used for testing shall conform to the requirements of Practices E4. The loads used for



the test method shall be within the loading range of the test machine as defined in Practices **E4**.

**A3.2.5 Load Fixture**—A suitable fixture shall be used to place a tensile load on the bone screw. The load shall maintain hold of the screw head and pull the screw perpendicular to the block surface throughout the test, allowing the screw to “self-align” during testing. An example of how this can be achieved is to design a slot either by mimicking the plate hole design or with a spherical recess into which the screw head can be seated directly under the applied load.

### **A3.3 Sampling, Test Specimens, and Test Units**

**A3.3.1** All test components shall be representative of implant quality products. Minimum sample size is  $n = 5$ .

### **A3.4 Procedure**

**A3.4.1 Insertion of the Test Specimen**—Drive the specimen into the test block, using the appropriate screwdriver bit, by applying a torsional force at a rate of 3 r/min to the head of the specimen with the machine actuator. For fully threaded screws, 20 mm of the thread length shall be inserted into the test block. For fully threaded screws with threaded lengths equal to or less than 20 mm, insert full thread length, but one thread below the screw’s head may be exposed in order to allow clearance for the test fixture. Partially threaded bone screws shall have all threads inserted into the standard material. The test specimen used for insertion torque measurement (**Annex A2**) can also be used for pullout load measurement (**Annex A3**).

**A3.4.2 Axial Pullout Load of the Test Specimen**—The test block and test block clamp depicted in **Annex A2** shall be fixed to the base of the load frame so that the longitudinal axis of the screw is aligned with the direction of the applied load. The screw’s head shall be placed in the slot of the load fixture and seated in the spherical recess. The load fixture shall then be attached to the load frame. A tensile load shall be applied to the test specimen at a rate of 5 mm/min until the screw fails or releases from the test block. Load (newtons) versus load fixture displacement (millimeters) shall be recorded on a data recorder, noting the maximum load applied and the mode of failure (screw shaft, screw threads, or test block material failure).

### **A3.5 Calculation or Interpretation of Results**

**A3.5.1 Axial Pullout Load**—Determine the axial pullout load (in newtons) of the test specimen from the load-displacement curve. The axial pullout load shall be the maximum load reading recorded during the pullout of the specimen.

### **A3.6 Report**

**A3.6.1** Report the following information:

**A3.6.1.1 Screw Identification**—Reference any applicable ASTM or ISO standard specification that may apply to the specimen. If a specification does not exist, provide head form, thread form, helix angle, major and minor diameter, thread pitch, overall screw length, head and shank length, length of the threaded portion of the shank for partially threaded screws, and type of screw point.

**A3.6.1.2** Screw material.

**A3.6.1.3** Screw surface finish.

**A3.6.1.4** Axial pullout load (as defined in **3.1.1**).

**A3.6.1.5** Minimum grip span applied in the test.

**A3.6.1.6** Insertion depth.

**A3.6.1.7** Minimum test block thickness applied in the test.

**A3.6.1.8** Mode of failure.

**A3.6.1.9 Test Block Material Description**—Specification **F1839** grade or density. For materials that do not conform to Specification **F1839**, provide the following information and the appropriate test methods used to determine the properties of the test block material:

**A3.6.1.9.1** Trade name,

**A3.6.1.9.2** Composition,

**A3.6.1.9.3** Density,

**A3.6.1.9.4** Tensile strength,

**A3.6.1.9.5** Compression strength, and

**A3.6.1.9.6** Shear strength.

**A3.6.1.10 Test Machine**—List relevant information about the test machine and provide the calibrated range of the load cell used.

**A3.6.1.11 Test Environment**—For example, air, room temperature, and other relevant environment information.

**A3.6.1.12** Deviations from this test method, including description and rationale/justification.

### **A3.7 Precision and Bias**

**A3.7.1** Data establishing the precision and accuracy to be expected from this test method have not yet been obtained.

**A4. TEST METHOD FOR DETERMINING THE SELF-TAPPING PERFORMANCE OF SELF-TAPPING MEDICAL BONE SCREWS**

**A4.1 Significance and Use**

A4.1.1 This test method is used to determine the axial compression load (force) required to engage the self-tapping feature of self-tapping medical bone screws into a standard material. The results obtained in this test method bear no direct correlation to the axial force required to insert the subject bone screw into human or animal bone. This test method is used only to measure the uniformity of the product tested or to compare the performance of different, yet similarly sized, products. This test method is not applicable to “self-drilling” or “self-drilling/self-tapping” styles of medical bone screws.

**A4.2 Apparatus**

A4.2.1 *Testing Apparatus*—A schematic for the axial self-tapping force test apparatus is illustrated in Fig. A4.1. The apparatus shall provide a variable speed motor capable of continuously driving a spindle. The spindle shall be capable of a continuous rotation as well as axial translation to allow variable force on the test specimen. The apparatus and spindle shall be sufficiently rigid to neither deflect nor deform under the conditions of loading encountered during the test. The apparatus shall incorporate a test block clamp for the purpose of rigidly fixing a test block. The apparatus shall be capable of continuously monitoring and recording the force, torque, and axial displacement of the specimen. The apparatus shall be calibrated for the range of forces, torques, and linear displacements used in the determination.

A4.2.2 *Compression Load Cell*—A transducer to translate the applied axial force into an electrical signal suitable for continuous recording and calibrated over the range of forces to be encountered in the test method, shall be provided. The load

cell should have an accuracy of 0.5 % of full-scale output and allow measurement resolution of  $\pm 1.0$  N.

A4.2.3 *Torque Transducer*—A transducer to translate the applied torque into an electrical signal suitable for continuous recording and calibrated over the range of torques, both in clockwise and counterclockwise rotation, to be encountered in the test method, shall be provided. The torque transducer should have an accuracy of 0.5 % of full-scale output and allow measurement resolution of  $\pm 0.10$  N-m.

NOTE A4.1—A combination compressive load and torque transducer is suitable for this application provided the transducer meets the specifications detailed in A4.2.2 and A4.2.3.

A4.2.4 *Linear Displacement Transducer*—A transducer to translate the axial displacement of the test apparatus’s spindle into an electrical signal suitable for continuous recording and calibrated over the range of displacements to be encountered in the test method, shall be provided. The displacement transducer should have an accuracy of 1 % of full scale and allow a measurement resolution of  $\pm 0.5$  mm.

A4.2.5 *Test Block Clamp*—A clamp or holding device shall be incorporated into the testing fixture. This holding device shall maintain the drilled pilot hole in the test block in line with the test specimen. The holding device shall be sufficiently rigid to neither deflect nor deform under the conditions of loading encountered during the test and yet not deform the test block during clamping of the test block or performance of the test.

A4.2.6 *Test Block*—The test block shall be fabricated from a uniform material that conforms to Specification F1839. The top and bottom surfaces shall be flat, smooth, and parallel (within 0.4 mm) as required to ensure that the test block will be supported in the fixture with the top surface at an angle of 90° to the centerline of the test specimen. The edges of the test block shall be of such contour or squareness as required to ensure that the test block clamp shall hold the test block free of relative motion without deformation of the test block during clamping or testing. The test block thickness shall be not less than 25 mm.

A4.2.7 *Pilot Holes in Test Block*—Pilot holes shall be drilled in the test block for insertion and removal of the test specimen. The drill size used shall be that specified by the screw manufacturer for the size screw being tested. The holes shall be drilled at 90° to the top surface of the test block. The holes shall be drilled straight and true, free of taper, bell mouth, or barrel shape. The holes should be drilled completely through the test block and all particulate debris removed prior to inserting the test specimen. If there are multiple holes in one test block, the pilot holes shall be spaced sufficiently far away from test block edges so that testing does not deform test block edges. Spacing should have a minimum distance as recommended in A2.2.1.7. When the test block is inserted into the

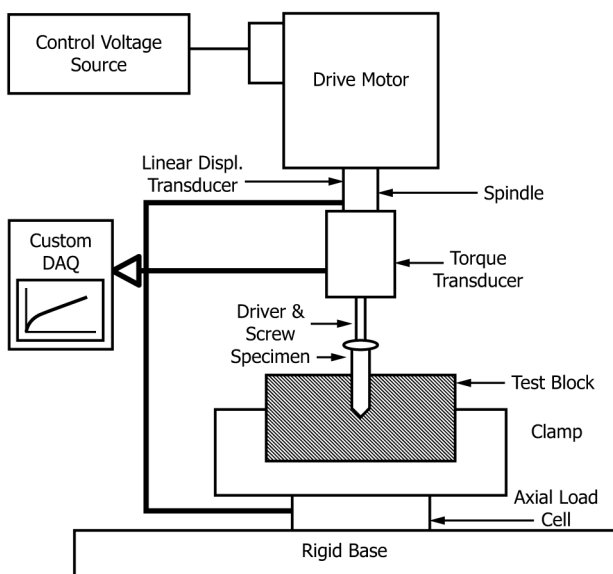

**FIG. A4.1 Schematic of Test Apparatus for Determination of Self-Tapping Force**

test fixture (Fig. A4.1), the pilot hole, screw, and screwdriver shall be on the same axis.

**A4.2.8 Test Specimen**—The test specimen shall be a completely fabricated and finished bone screw of sufficient length to allow completion of the test.

**A4.2.9 Recorder**—The data recorder shall be suitable to record continuously, at a minimum rate of 10 Hz, axial compression force, torque, and axial spindle displacement. The recorder shall be capable of recording two Y axes simultaneously (force and torque to Y Axis 1 and displacement to Y Axis 2) versus time (X axis), calibrated in units of newtons for force, newton-meters for torque, and millimeters for displacement. The value of force and torque should have a resolution of 0.5 % of full-scale output and sensitivity so as to enable an accurate recording capability of a minimum of 1.0 N and 0.10 N-m, respectively. The value of torque shall have a resolution of 0.5 % of full-scale output. The linear displacement scale should have a minimum sensitivity so as to enable an accurate recording capability for 0.5 mm.

**A4.2.10 Test Speed**—The torsional force shall be applied at a constant rate of 30 r/min. The axial compression force shall be applied at a constant rate of approximately 2 N/s. The torsional test speed has been selected to represent the clinical situation of hand-driven screws. The axial load rate has been selected to allow easy identification and reaction to the unique self-tap events on the data output recorder. Other test speeds and load rates can be used provided they are justified and reported. All comparative tests shall be performed at the same test speeds.

**A4.3 Sampling**

**A4.3.1** Representative random samples may be taken from each lot or processing quantity in accordance with Practice E122.

**A4.4 Procedure**

**A4.4.1 Self-Tapping Force**—The pre-drilled test block is rigidly fixed in the test block clamp device shown in Fig. A1.1. The appropriate sized screwdriver (“driver”) is inserted into the spindle and the alignment of the pilot hole with the driver is verified. The self-tapping bone screw specimen is then pre-assembled (“loaded”) onto the driver. The specimen/driver assembly is then lowered via the spindle into the pilot hole and the axial displacement of the spindle adjusted to achieve a maximum preload of 1.0 N to maintain screw-to-screwdriver engagement.

**A4.4.2** The specimen is then driven by the test apparatus at a constant rotational rate of 30 revolutions/minute (r/min). The axial force, torque, and displacement channels on the data recorder are monitored simultaneously while the axial force is increased at a rate of approximately 2.0 N/s (± 1.0 N/s). The axial compression force shall continue to be increased until the self-tapping features of the screw engage the test block as indicated by a marked increase in torque and axial displacement as shown in Fig. A4.2.

**A4.4.3** This unique combination signifies the engagement of the self-tapping features of the bone screw into the test

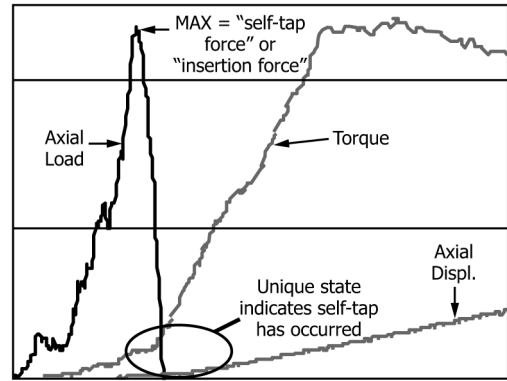

FIG. A4.2 Typical Test Method Output

material and the onset of “self-tap.” At this moment, the increase in axial force should be discontinued and the load level at which self-tap was first noted maintained (that is, “load and hold”) while simultaneously monitoring the specimen to ensure the continued self-advance into the test block as noted by the continually increasing torque and axial displacement. (Note that in some instances the axial force may decrease at the onset of self-tap, as shown in Fig. A4.2, indicating self-advancement of the specimen into the test block without the need for continuous, applied force. Thus, during this phase of the test, the axial force serves only to maintain driver-to-screw engagement.)

**A4.4.4** A total of five complete revolutions should be achieved after the onset of self-tap to be considered a valid specimen. The maximum axial force achieved at the onset of self-tap shall be reported as the “self-tap force.” Values should be reported in newtons. On occasion, the specimen will self-tap and then cease advancement into the test block (“stall” or “strip”) within the first five revolutions, as indicated by a rapid loss of torsional resistance and an unchanging (“flatlined”) axial displacement. When a specimen stalls, the resumption of the increase in axial force at a rate of 2.0 N/s (±1.0 N/s) is acceptable to once again achieve self-tap provided: (1) the secondary, maximum axial force is reported as the “self-tap force”; (2) the specimen completes five revolutions after the secondary self-tap; and (3) the specimen is indicated as “stalled” or “stripped” in the Comments section of the test report. Any specimen that stalls more than once shall be considered invalid.

**A4.5 Report**

**A4.5.1** Report the following information for each specimen tested (all standard units for reporting shall be in SI units):

**A4.5.1.1 Screw Identification**—Reference any applicable ASTM or ISO specification that may apply to the specimen. If specifications do not exist, provide head form, thread form, major and minor diameter, thread pitch, overall screw length, head and shank (unthreaded portion of the screw excluding the head) length, and type of screw point.

**A4.5.1.2** Screw chemical composition.

**A4.5.1.3** Ultimate tensile strength.

**A4.5.1.4** Surface finish.

**A4.5.1.5** Self-tap force.