



Designation: C1782/C1782M – 23

# Standard Specification for Segmental Concrete Paving Slabs<sup>1</sup>

This standard is issued under the fixed designation C1782/C1782M; the number immediately following the designation indicates the year of original adoption or, in the case of revision, the year of last revision. A number in parentheses indicates the year of last reapproval. A superscript epsilon ( $\epsilon$ ) indicates an editorial change since the last revision or reapproval.

## 1. Scope\*

1.1 This specification covers the requirements for segmental concrete paving slabs manufactured for construction of pedestrian and roof applications for commercial and municipal projects. These slabs can be manufactured with a dry-cast, wet-cast, or hydraulically pressed process.

NOTE 1—Pedestal-set applications and those applications subject to vehicular traffic may require alternate materials properties or structural support or both.

1.2 Concrete units covered by this specification shall be made with lightweight or normal weight aggregates or both.

NOTE 2—If particular features are desired, such as weight classification, higher modulus of rupture, surface textures, finish, color, or other special features, such properties should be specified by the purchaser. Local sellers, however, should be consulted as to availability of units having the desired features.

1.3 The values stated in either inch-pound units or SI units are to be regarded separately as standard. The values stated in each system may not be exact equivalents; therefore, each system shall be used independently of the other. Combining values from the two systems may result in non-conformance with the standard.

1.4 *This international standard was developed in accordance with internationally recognized principles on standardization established in the Decision on Principles for the Development of International Standards, Guides and Recommendations issued by the World Trade Organization Technical Barriers to Trade (TBT) Committee.*

## 2. Referenced Documents

### 2.1 ASTM Standards:

- C33/C33M Specification for Concrete Aggregates
- C140/C140M Test Methods for Sampling and Testing Concrete Masonry Units and Related Units
- C150/C150M Specification for Portland Cement
- C207 Specification for Hydrated Lime for Masonry Purposes

<sup>1</sup> This test method is under the jurisdiction of ASTM Committee C15 on Manufactured Masonry Units and is the direct responsibility of Subcommittee C15.03 on Concrete Masonry Units and Related Units.

Current edition approved June 15, 2023. Published June 2023. Originally approved in 2016. Last previous edition approved in 2021 as C1782/C1782M – 21. DOI: 10.1520/C1782\_C1782M-23.

- C331/C331M Specification for Lightweight Aggregates for Concrete Masonry Units
- C595/C595M Specification for Blended Hydraulic Cements
- C618 Specification for Coal Ash and Raw or Calcined Natural Pozzolan for Use in Concrete
- C979/C979M Specification for Pigments for Integrally Colored Concrete
- C989/C989M Specification for Slag Cement for Use in Concrete and Mortars
- C1157/C1157M Performance Specification for Hydraulic Cement
- C1232 Terminology for Masonry
- C1240 Specification for Silica Fume Used in Cementitious Mixtures
- C1645 Test Method for Freeze-thaw and De-icing Salt Durability of Solid Concrete Interlocking Paving Units
- D1056 Specification for Flexible Cellular Materials—Sponge or Expanded Rubber

## 3. Terminology

3.1 Terminology defined in C1232 shall apply for this specification.

### 3.2 Definitions of Terms Specific to This Standard:

3.2.1 *warpage, n*—the maximum vertical deviation from a straightedge placed across the full length, width or diagonal dimension of the paving slab surface.

## 4. Materials

4.1 *Cementitious Materials*—Materials shall conform to the following applicable specifications:

- 4.1.1 *Portland Cements*—Specification C150/C150M.
- 4.1.2 *Modified Portland Cement*—Portland cement conforming to Specification C150/C150M, modified as follows:
  - (1) *Limestone*—If calcium carbonate is added to the cement, the CaCO<sub>3</sub> content shall not be less than 85 %.
  - (2) *Limitation on Insoluble Residue*—1.5 %.
  - (3) *Limitation on Air Content of Mortar*—Volume percent, 22 % max.
  - (4) *Limitation on Loss on Ignition*—7 %.
- 4.1.3 *Hydraulic Cements*—Specification C1157/C1157M.
- 4.1.4 *Blended Hydraulic Cements*—Specification C595/C595M.
- 4.1.5 *Pozzolans*—Specification C618.
- 4.1.6 *Slag Cement*—Specification C989/C989M.

\*A Summary of Changes section appears at the end of this standard

4.1.7 *Silica Fume*—Specification C1240.

4.2 *Aggregates*—Aggregates shall conform to the following specifications, except for the grading requirements:

4.2.1 *Normal Weight Aggregates*—Specification C33/C33M.

4.2.2 *Lightweight Aggregates*—Specification C331/C331M.

NOTE 3—The grading requirements of Specifications C33/C33M and C331/C331M may not be suitable for segmental concrete paving slab production. Because of this, producers are allowed to modify grading to meet their needs and the requirements of this specification.

4.3 *Pigments for Integrally Colored Concrete*—Specification C979/C979M.

4.4 *Other Constituents*—Air-entraining agents, integral water repellents, and other constituents shall be previously established as suitable for use in segmental concrete paving slabs and shall conform to applicable ASTM standards or shall be shown by test or experience not to be detrimental to the durability of the segmental concrete paving slabs or any material customarily used in segmental pavement construction.

5. Physical Requirements

5.1 Units shall have a finished face area greater than 101 in.<sup>2</sup> [0.065 m<sup>2</sup>] and their length (L) divided by thickness (T) shall be greater than 4. The minimum thickness shall be 1.2 in. [30 mm]. The maximum length and width dimensions shall be 48 in. [1220 mm]. See Fig. 1.

5.2 *Modulus of Rupture*—At the time of delivery to the job site, the average modulus of rupture of the test specimens shall be 725 psi [5.0 MPa] with no individual unit less than 650 psi [4.5 MPa] as determined in accordance with 7.4.

5.3 *Resistance to Freezing and Thawing*—If the units are exposed to freezing and thawing during service, the manufacturer shall satisfy the purchaser either by proven field performance or a laboratory freezing-and-thawing test that the units have adequate resistance to freezing and thawing. If a labora-

tory test is used, test in accordance with 7.4. Specimens sampled from units that will not be exposed to deicing salts in service shall be tested in tap water. Specimens sampled from units that will be exposed to deicing materials in service shall be tested in 3 % saline solution. The average mass loss of all the specimens tested shall not be greater than: (a) 225 g/m<sup>2</sup> when subject to 28 freeze-thaw cycles, or (b) 500 g/m<sup>2</sup> when subject to 49 freeze-thaw cycles.

5.4 *Dimensional Tolerances*—At the time of delivery to the job site, the length, width and thickness dimensions, and concave or convex warpage measured across the full length, width and diagonal dimensions, as determined in accordance with 7.3, shall not differ from the amounts for the specified dimensions by more than the tolerances in Table 1. Length, width and thickness dimensions are based on specified dimensions for the particular shape identified.

NOTE 4—Some applications including units placed on a sand-bitumen setting bed or on pedestals for roof applications may require tighter dimensional tolerances for thickness and warpage than those shown in Table 1. These tolerances should be specified separately.

6. Visual Inspection

6.1 All units shall be sound and free of defects that would interfere with the proper placing of the units or impair the strength or performance of the construction. Cracks or surface chipping resulting from customary methods of manufacturing or handling in shipment and delivery shall not be deemed grounds for rejection.

7. Sampling and Testing

7.1 The purchaser or the purchaser’s authorized representative shall be accorded proper facilities to inspect and sample the units at the place of manufacture from the lots ready for delivery. Prior to delivery of units, the supplier and purchaser shall decide on the lot size from which to sample test

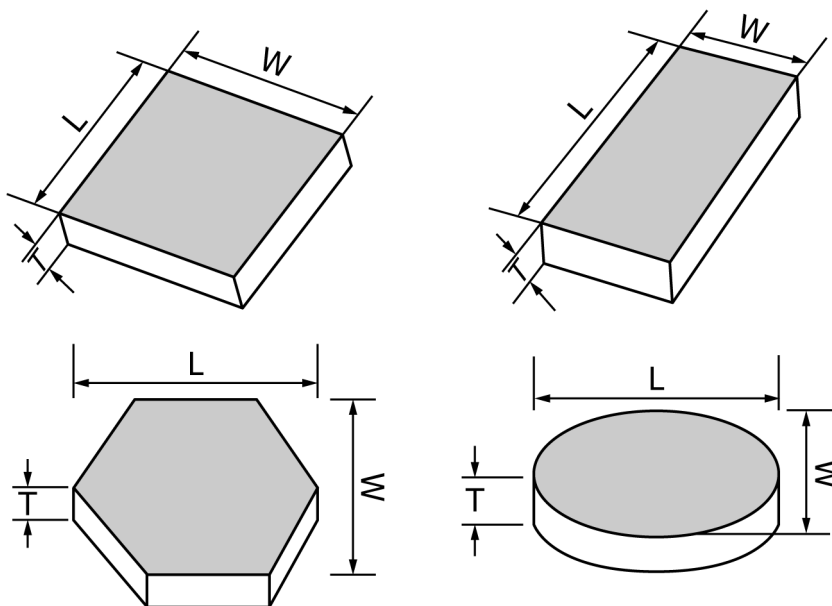

FIG. 1 L = Length, W = Width, T = Thickness

**TABLE 1 Dimensional Tolerances**

Length and Width, in. [mm]	Thickness, in. [mm]	Concave or Convex Warpage in One Dimension, in. [mm]
Units up to and including 24 in. [610 mm]		Up to and including 17.75 in. [450 mm]:
-0.04 [1.0] and +0.08 [2.0]	±0.12 [3.0]	±0.08 [2.0]
Units over 24 in. [610 mm]		Over 17.75 in. [450 mm]
-0.06 [1.5] and +0.12 [3.0]	±0.12 [3.0]	±0.12 [3.0]

specimens for resistance to freezing and thawing, modulus of rupture, and dimensional tolerances.

7.2 Sample paving slabs that are representative of the lot and label with the date of manufacture.

7.3 Three units of any configuration or dimensions manufactured with the same materials, concrete mix design, manufacturing process, and curing method shall be checked for dimensional variations in accordance with Test Method **C140/C140M**, Annex A8, not more than 12 months prior to delivery. Measure the length, width, and thickness for conformance to manufacturer's specified dimensions and for warpage across the full length, width and diagonal dimensions to the nearest 0.02 in. [0.5 mm]. These units shall be used for modulus of rupture testing and, if applicable, three additional units shall be tested for resistance to freezing and thawing as described **7.4** and **7.4.1**.

7.4 Three units of any configuration or dimensions manufactured with the same materials, concrete mix design, manufacturing process, and curing method shall be tested for modulus of rupture in accordance with Test Method **C140/C140M**, Annex A8, not more than 12 months prior to delivery. When required, three units of any configuration or dimensions manufactured with the same materials, concrete mix design, manufacturing process, and curing method shall be tested for resistance to freezing and thawing in accordance with Test Method **C1645** not more than 24 months prior to delivery.

7.4.1 If applicable, each of the three test specimens for resistance to freezing and thawing shall be cut from three separate units. The freeze-thaw test specimens shall have a surface area of at least 29.5 in.<sup>2</sup> [0.019 m<sup>2</sup>] and not exceeding 101 in.<sup>2</sup> [0.065 m<sup>2</sup>], and have at least two edges that are uncut.

## 8. Compliance

8.1 If a sample fails to conform to the specified requirements, the manufacturer shall be permitted to remove paving slabs from the shipment. A new sample shall be selected by the purchaser from remaining slabs from the shipment with a similar configuration and dimension and tested. If the second sample meets the specified requirements, the remaining portion of the shipment represented by the sample meets the specified requirements. If the second sample fails to meet the specified requirements, the remaining portion of the shipment represented by the sample fails to meet the specified requirements.

NOTE 5—Unless otherwise specified in the purchase order, the cost of tests is typically borne as follows: (1) if the results of the tests show that the slabs do not conform to the requirements of this specification, the cost is typically borne by the seller; (2) if the results of the tests show that the units conform to the specification requirements, the cost is typically borne by the purchaser.

## 9. Keywords

9.1 concrete; concrete paving unit; segmental concrete paving slab

## SUMMARY OF CHANGES

Committee C15 has identified the location of selected changes to this standard since the last issue (C1782/C1782M – 21) that may impact the use of this standard. (June 15, 2023)

(1) Modified Section 4 to clarify that grading requirements do not apply for aggregates, include requirements for modified portland cement, and clean up language on other constituents.

(2) Added reference in 7.3 and 7.4 to Annex A8 relative to C140 testing for segmental concrete paving slabs.