



Designation: D6923 – 23

Standard Test Method for Evaluation of Engine Oils in a High Speed, Single-Cylinder Diesel Engine—Caterpillar 1R Test Procedure¹

This standard is issued under the fixed designation D6923; the number immediately following the designation indicates the year of original adoption or, in the case of revision, the year of last revision. A number in parentheses indicates the year of last reapproval. A superscript epsilon (ϵ) indicates an editorial change since the last revision or reapproval.

INTRODUCTION

Any properly equipped laboratory, without outside assistance, can use the test procedure described in this test method. The ASTM Test Monitoring Center (TMC)² provides calibration oils and an assessment of the test results obtained on those oils by the laboratory. By this means, the laboratory will know whether their use of the test method gives results statistically similar to those obtained by other laboratories. Furthermore, various agencies require that a laboratory utilize the TMC services in seeking qualification of oils against specifications. For example, the U.S. Army has such a requirement in some of its engine oil specifications. Accordingly, this test method is written for those laboratories that use the TMC services. Laboratories that choose not to use these services should ignore those portions of the test method that refer to the TMC. Information Letters issued periodically by the TMC may modify this test method. In addition, the TMC may issue supplementary memoranda related to the test method.

ASTM International policy is to encourage the development of test procedures based on generic equipment. It is recognized that there are occasions where critical/sole-source equipment has been approved by the technical committee (surveillance panel/task force) and is required by the test procedure. The technical committee that oversees the test procedure is encouraged to clearly identify if the part is considered critical in the test procedure. If a part is deemed to be critical, ASTM encourages alternative suppliers to be given the opportunity for consideration of supplying the critical part/component providing they meet the approval process set forth by the technical committee.

An alternative supplier can start the process by initiating contact with the technical committee (current chairs shown on ASTM TMC website). The supplier should advise on the details of the part that is intended to be supplied. The technical committee will review the request and determine feasibility of an alternative supplier for the requested replacement critical part. In the event that a replacement critical part has been identified and proven equivalent the sole-source supplier footnote shall be removed from the test procedure.

1. Scope*

1.1 This test method covers stressing an engine oil under modern high-speed diesel operating conditions and measures the oil's deposit control, lubrication ability, and resistance to

¹ This test method is under the jurisdiction of ASTM Committee D02 on Petroleum Products, Liquid Fuels, and Lubricants and is the direct responsibility of Subcommittee D02.B0 on Automotive Lubricants.

Current edition approved July 1, 2023. Published July 2023. Originally approved in 2003. Last previous edition approved in 2018 as D6923 – 18. DOI: 10.1520/D6923-23.

² Until the next revision of this test method, the ASTM Test Monitoring Center (TMC) will update changes in the test method by means of information letters. Information letters may be obtained from the ASTM Test Monitoring Center, 203 Armstrong Drive, Freeport, PA 16229. Attention: Director. This edition incorporates revisions in all information Letters through No. 23-1.

oil consumption. It is performed in a laboratory using a standardized high-speed, single-cylinder diesel engine.³

1.2 The values stated in SI units are to be regarded as standard. No other units of measurement are included in this standard.

1.2.1 *Exceptions*—Where there is no direct SI equivalent such as screw threads, national pipe threads/diameters, and tubing size, or where a sole source supplier is specified.

1.3 *This standard does not purport to address all of the safety concerns, if any, associated with its use. It is the*

³ Available from Caterpillar Inc., Engine System Technology Development, P.O. Box 610, Mossville, IL 61552-0610.

*A Summary of Changes section appears at the end of this standard

responsibility of the user of this standard to establish appropriate safety, health, and environmental practices and determine the applicability of regulatory limitations prior to use. Being an engine test method, this test method does have definite hazards that require safe practices (see [Appendix X2](#) on Safety).

1.4 The following is the Table of Contents:

Scope	1
Referenced Documents	2
Terminology	3
Summary of Test Method	4
Significance and Use	5
Apparatus and Installation	6
Intake Air System	6.2.1
Exhaust System	6.2.2
Fuel System	6.2.3
Oil Consumption System	6.2.4
Engine Oil System	6.2.5
Engine Coolant System	6.2.6
Engine Instrumentation	6.2.7
Reagents and Materials	7
Oil Samples	8
Preparation of Apparatus	9
General Engine Assembly Practices	9.1
Complete Engine Inspection	9.2
Copper Component	9.3
Engine Lubricant System Flush	9.4
Engine Piston Cooling Jet	9.5
Engine Measurements and Inspections	9.6
Cylinder Head	9.7
Valve Guide Bushings	9.8
Fuel Injector	9.9
Piston and Rings	9.10
Cylinder Liner	9.11
Compression Ratio	9.12
Engine Timing	9.13
Engine Coolant System Cleaning Procedure	9.14
Calibration and Standardization	10
Test Cell Instrumentation	10.1
Instrumentation Standards	10.2
Coolant Flow	10.3
Fuel Injectors	10.4
Air Flow	10.5
Intake Air Barrel	10.6
Fuel Filter	10.7
Oil Scale Flow Rates	10.8
Test Stand Calibration	10.9
Re-calibration Requirements	10.9.1
Extending Test Stand Calibration Period	10.9.2
Test Run Numbering	10.10
Humidity Calibration Requirements	10.11
Calibration of Piston Deposit Raters	10.12
Procedure	11
Engine Break-in Procedure	11.1
Cool-down Procedure	11.2
Warm-up Procedure	11.3
Shutdowns and Lost Time	11.4
Periodic Measurements	11.5
Engine Control Systems	11.6
Engine Coolant	11.6.1
Engine Fuel System	11.6.2
Engine Oil Temperature	11.6.3
Exhaust Pressure	11.6.4
Intake Air	11.6.5
Post-Test Procedures	11.7
Piston Ring Side Clearances	11.7.1
Piston Ratings	11.7.2
Ring Gap End Increase	11.7.3
Cylinder Liner Wear	11.7.4
Cylinder Liner Bore Polish	11.7.5
Photographs	11.7.6
Calculation and Interpretation of Results	12
Test Validity	12.1
Calculations	12.4
Quality Index	12.4.1

Oil Consumption Report	12.4.2
Forms and Data Dictionary	13
Test Validity	13.1
Report Specifics	13.2
Precision and Bias	13.3
Precision	14
Bias	14.1
Keywords	14.2
Annexes	9.11.1
Engine and Parts Warranty	Annex A1
Instrument Locations, Measurements and Calculations	Annex A2
Cooling System Arrangement	Annex A3
Intake Air Mass Flow Sensor Installation	Annex A4
Fuel System Design and Required Components	Annex A5
Oil System	Annex A6
Additional Report Forms	Annex A7
Engine Assembly and Inspection Information	Annex A8
Flushing Instructions and Apparatus	Annex A9
Warm-up, Cool-down and Testing Conditions	Annex A10
Piston and Liner Rating Modifications	Annex A11
Return Goods Authorization Claim Form	Annex A12
Appendixes	
Various Examples of Supplemental Information for Reference Purposes	Appendix X1
Safety	Appendix X2

1.5 *This international standard was developed in accordance with internationally recognized principles on standardization established in the Decision on Principles for the Development of International Standards, Guides and Recommendations issued by the World Trade Organization Technical Barriers to Trade (TBT) Committee.*

2. Referenced Documents

2.1 ASTM Standards:⁴

- [D86 Test Method for Distillation of Petroleum Products and Liquid Fuels at Atmospheric Pressure](#)
- [D93 Test Methods for Flash Point by Pensky-Martens Closed Cup Tester](#)
- [D97 Test Method for Pour Point of Petroleum Products](#)
- [D130 Test Method for Corrosiveness to Copper from Petroleum Products by Copper Strip Test](#)
- [D235 Specification for Mineral Spirits \(Petroleum Spirits\) \(Hydrocarbon Dry Cleaning Solvent\)](#)
- [D445 Test Method for Kinematic Viscosity of Transparent and Opaque Liquids \(and Calculation of Dynamic Viscosity\)](#)
- [D524 Test Method for Ramsbottom Carbon Residue of Petroleum Products](#)
- [D613 Test Method for Cetane Number of Diesel Fuel Oil](#)
- [D664 Test Method for Acid Number of Petroleum Products by Potentiometric Titration](#)
- [D976 Test Method for Calculated Cetane Index of Distillate Fuels](#)
- [D1298 Test Method for Density, Relative Density, or API Gravity of Crude Petroleum and Liquid Petroleum Products by Hydrometer Method](#)
- [D1319 Test Method for Hydrocarbon Types in Liquid Petroleum Products by Fluorescent Indicator Adsorption](#)

⁴ For referenced ASTM standards, visit the ASTM website, www.astm.org, or contact ASTM Customer Service at service@astm.org. For *Annual Book of ASTM Standards* volume information, refer to the standard's Document Summary page on the ASTM website.

D2500 Test Method for Cloud Point of Petroleum Products and Liquid Fuels

D2622 Test Method for Sulfur in Petroleum Products by Wavelength Dispersive X-ray Fluorescence Spectrometry

D2709 Test Method for Water and Sediment in Middle Distillate Fuels by Centrifuge

D3338 Test Method for Estimation of Net Heat of Combustion of Aviation Fuels

D3524 Test Method for Diesel Fuel Diluent in Used Diesel Engine Oils by Gas Chromatography

D4052 Test Method for Density, Relative Density, and API Gravity of Liquids by Digital Density Meter

D4175 Terminology Relating to Petroleum Products, Liquid Fuels, and Lubricants

D4485 Specification for Performance of Active API Service Category Engine Oils

D4739 Test Method for Base Number Determination by Potentiometric Hydrochloric Acid Titration

D4863 Test Method for Determination of Lubricity of Two-Stroke-Cycle Gasoline Engine Lubricants (Withdrawn 2022)⁵

D5185 Test Method for Multielement Determination of Used and Unused Lubricating Oils and Base Oils by Inductively Coupled Plasma Atomic Emission Spectrometry (ICP-AES)

D5302 Test Method for Evaluation of Automotive Engine Oils for Inhibition of Deposit Formation and Wear in a Spark-Ignition Internal Combustion Engine Fueled with Gasoline and Operated Under Low-Temperature, Light-Duty Conditions (Withdrawn 2003)⁵

D5844 Test Method for Evaluation of Automotive Engine Oils for Inhibition of Rusting (Sequence IID) (Withdrawn 2003)⁵

D5862 Test Method for Evaluation of Engine Oils in Two-Stroke Cycle Turbo-Supercharged 6V92TA Diesel Engine (Withdrawn 2009)⁵

D5966 Test Method for Evaluation of Engine Oils for Roller Follower Wear in Light-Duty Diesel Engine

D5967 Test Method for Evaluation of Diesel Engine Oils in T-8 Diesel Engine

D6202 Test Method for Automotive Engine Oils on the Fuel Economy of Passenger Cars and Light-Duty Trucks in the Sequence VIA Spark Ignition Engine (Withdrawn 2009)⁵

D6594 Test Method for Evaluation of Corrosiveness of Diesel Engine Oil at 135 °C

D6681 Test Method for Evaluation of Engine Oils in a High Speed, Single-Cylinder Diesel Engine—Caterpillar 1P Test Procedure

E29 Practice for Using Significant Digits in Test Data to Determine Conformance with Specifications

E344 Terminology Relating to Thermometry and Hydrometry

G40 Terminology Relating to Wear and Erosion

2.2 *Other ASTM Document:*

ASTM Deposit Rating Manual 20 (formerly CRC Manual 20)⁶

2.3 *SAE Standard:*

SAE J183 Engine Oil Performance and Engine Service Classification⁷

2.4 *API Standard:*

API 1509 Engine Service Classification and Guide to Crankcase Oil Selection⁸

3. Terminology

3.1 *Definitions:*

3.1.1 *additive, n*—a material added to another, usually in small amounts, to impart or enhance desirable properties or to suppress undesirable properties. **D4175**

3.1.2 *automotive, adj*—descriptive of equipment associated with self-propelled machinery, usually vehicles driven by internal combustion engines. **D4485**

3.1.3 *blind reference oil, n*—a reference oil, the identity of which is unknown by the test facility.

3.1.3.1 *Discussion*—This is a coded reference oil, which is submitted by a source independent from the test facility. **D5844**

3.1.4 *blowby, n*—in internal combustion engines, the combustion products and unburned air-and-fuel mixture that enter the crankcase. **D5302**

3.1.5 *calibrate, v*—to determine the indication or output of a measuring device with respect to that of a standard. **E344**

3.1.6 *calibrated test stand, n*—a test stand on which the testing of reference material(s), conducted as specified in the standard, provided acceptable test results.

3.1.6.1 *Discussion*—In several automotive lubricant standard test methods, the TMC² provides testing guidance and determines acceptability. **D6681**

3.1.7 *candidate oil, n*—an oil which is intended to have the performance characteristics necessary to satisfy a specification and is to be tested against that specification. **D5844**

3.1.8 *debris, n*—in internal combustion engines, solid contaminant materials unintentionally introduced into the engine or resulting from wear. **D5862**

3.1.9 *dispersant, n*—in engine oil, an additive that reduces deposits on oil-wetted surfaces primarily through suspension of particles. **D4175**

3.1.10 *engine oil, n*—a liquid that reduces friction or wear, or both, between the moving parts within an engine; removes heat, particularly from the underside of pistons; and serves as a combustion gas sealant for the piston rings.

3.1.10.1 *Discussion*—It may contain additives to enhance certain properties. Inhibition of engine rusting, deposit formation, valve train wear, oil oxidation and foaming are examples. **D5862**

⁶ For Stock #TMCNML20, visit the ASTM website, www.astm.org, or contact ASTM International Customer Service at service@astm.org.

⁷ Available from Society of Automotive Engineers (SAE), 400 Commonwealth Dr., Warrendale, PA 15096-0001.

⁸ Available from The American Petroleum Institute (API), 1220 L. St., NW, Washington, DC 20005.

⁵ The last approved version of this historical standard is referenced on www.astm.org.

3.1.11 *heavy-duty, adj—in internal combustion engine operation*, characterized by average speeds, power output and internal temperatures that are close to the potential maximums.

D4485

3.1.12 *lubricant, n—any material interposed between two surfaces that reduces the friction or wear, or both, between them.*

D5862

3.1.13 *lubricating oil, n—a liquid lubricant, usually comprising several ingredients, including a major portion of base oil and minor portions of various additives.*

D5966

3.1.14 *non-reference oil, n—any oil other than a reference oil; such as a research formulation, commercial oil or candidate oil.*

D5844

3.1.15 *oxidation, n—of engine oil*, the reaction of the oil with an electron acceptor, generally oxygen, that can produce deleterious acidic or resinous materials often manifested as sludge formation, varnish formation, viscosity increase, or corrosion, or combination thereof.

D6681

3.1.16 *purchaser, n—of an ASTM test*, person or organization that pays for the conduct of an ASTM test method on a specified product.

D6202

3.1.17 *reference oil, n—an oil of known performance characteristics, used as a basis for comparison.*

3.1.17.1 *Discussion—Reference oils are used to calibrate testing facilities, to compare the performance of other oils, or to evaluate other material (such as seals) that interact with oils.*

D5844

3.1.18 *scoring, n—in tribology*, a severe form of wear characterized by the formation of extensive grooves and scratches in the direction of sliding.

G40

3.1.19 *scuff, scuffing, n—in lubrication*, damage caused by instantaneous localized welding between surfaces in relative motion that does not result in immobilization of the parts.

D4863

3.1.20 *sponsor, n—of an ASTM test method*, an organization that is responsible for ensuring supply of the apparatus used in the test procedure portion of the test method.

3.1.20.1 *Discussion—In some instances, such as a test method for chemical analysis, an ASTM working group can be the sponsor of the test method. In other instances, a company with a self-interest may or may not be the developer of the test procedure used within the test method, but is the sponsor of the test method.*

D6594

3.1.21 *used oil, n—any oil that has been in a piece of equipment (for example, an engine, gearbox, transformer, or turbine), whether operated or not.*

D4175

3.1.22 *varnish, n—in internal combustion engines*, a hard, dry, generally lustrous deposit that can be removed by solvents but not by wiping with a cloth.

D5302

3.1.23 *wear, n—the loss of material from, or relocation of material on, a surface.*

3.1.23.1 *Discussion—Wear generally occurs between two surfaces moving relative to each other, and it is the result of mechanical or chemical action or by a combination of mechanical and chemical actions.*

D5302

4. Summary of Test Method

4.1 Prior to each test, the power section of the engine is disassembled, solvent-cleaned, measured, and rebuilt in strict accordance with the specifications. A new piston, ring assembly, and cylinder liner are measured and installed for each test. The engine crankcase is solvent-cleaned, and worn or defective parts are replaced. The test stand is equipped with feedback control systems for fuel rate, engine speed, and other engine operating conditions. Provide a suitable system for filtering, compressing, humidifying, and heating the inlet air along with a system for controlling the engine exhaust pressure. Test operation involves the control of the single-cylinder diesel test engine, using the test oil as a lubricant, at a specified speed and fuel rate input, for a total of 504 h. A defined break-in precedes each test. A prescribed warm-up is used when restarting the engine. At the end of the test, the piston deposits are rated; the piston, rings and liners are inspected, measured, and photographed; oil consumption is calculated, and the oil is analyzed to determine the test results. Critical engine operating conditions are statistically analyzed to determine if the test was precisely operated. Test acceptability parameters, for each calibration test, are also statistically analyzed to determine if the engine/test stand produce the specified results.

5. Significance and Use

5.1 This is an accelerated engine oil test, performed in a standardized, calibrated, stationary single-cylinder diesel engine that gives a measure of (1) piston and ring groove deposit forming tendency, (2) piston, ring, and liner scuffing and (3) oil consumption. The test is used in the establishment of diesel engine oil specification requirements as cited in Specification **D4485** for appropriate API Performance Category C oils (API 1509). The test method can also be used in diesel engine oil development.

6. Apparatus and Installation

6.1 The test engine is an electronically controlled, direct injection, in-head camshaft, and single-cylinder diesel engine with a four-valve arrangement. The engine has a 137.2 mm bore and a 165.1 mm stroke resulting in a displacement of 2.4 L.

6.1.1 The Electronic Control Module (ECM) defines the desired engine fuel timing, monitors and limits maximum engine speed, maximum engine power, minimum oil pressure, and, optionally, maximum engine crankcase pressure. The ECM also controls the fuel injection duration that defines the engine fuel rate based on set conditions from the test cell feedback control systems. The oil pressure is also set by the ECM with signals to the 1Y3867 Engine Air Pressure Controller (Mamac) to modulate the facility air supply to the 1Y3898 Johnson Controls Relief Valve.

6.1.2 The 1Y3700 engine arrangement also consists of inlet air piping and hoses from the cylinder head to the air barrel and exhaust piping and bellows from the cylinder head to the exhaust barrel that are specifically designed for oil testing.³

6.2 Equip the engine test stand with the following accessories or equipment:

6.2.1 *Intake Air System*—The intake air system components from the cylinder head to the air barrel are a part of the basic 1Y3700 engine arrangement. These components consisting of an adapter, elbow, hose, clamps, and flanged tube can be found in the 1Y3700 Parts Book.³

6.2.1.1 Purchase the 1Y3978 intake air barrel (which is almost identical to the exhaust barrel except for the top cover) from one of the three approved manufacturers.⁹ Install the intake air barrel at the location shown in **Annex A2**. Do not add insulation to the barrel.

6.2.1.2 Paint the inside of the intake air piping with Caterpillar yellow primer or red Glyptal prior to installation.¹⁰

6.2.1.3 Install the air heater elements in the intake air barrel as specified in **Annex A2** (even if they will not be supplied with electricity).^{11,12}

6.2.1.4 Use an air filter capable of 10 µm (or smaller) filtration.

6.2.1.5 Use a Sierra Model 780 airflow meter with Feature 1 = F6, Feature 2 = CG and calibrated at the following conditions to measure intake airflow for each calibration test:^{13,12}

Temperature = 60 °C
 Humidity = 17.8 g/kg
 Pressure = 292 kPa (abs)
 Approximate flow range = 425 kg/h

Annex A4 shows the piping requirements for the installation of the Sierra Model 780 airflow meter. For tests not using the airflow meter, maintain instrumentation configuration using a spool piece of equivalent dimensions.

6.2.1.6 Measure the inlet air temperature at the location shown in **Annex A2**. Measure the inlet air pressure at the air barrel as shown in **Annex A2**. The location of the 1Y3977 Humidity Probe is shown in **Annex A4**. The sample line may require insulation to prevent dropping below dew point temperature and shall not be hygroscopic. Drain taps may be installed at the low points of the combustion air system.

6.2.1.7 Use feedback-equipped controls to maintain filtered, compressed, and humidified inlet air at the conditions specified in **Annex A10**.

6.2.2 *Exhaust System*—The exhaust system components from the cylinder head to the exhaust barrel are part of the basic 1Y3700 engine arrangement. These components consisting of an adapter, elbow, bellows, flange, and clamps can be found in the 1Y3700 Parts Book.

6.2.2.1 Purchase the 1Y3976 exhaust barrel (which is almost identical to the intake barrel except for the top cover)

from one of the three approved manufacturers.⁹ Install the exhaust barrel at the location shown in **Annex A2**. Do not add insulation to the barrel. Any of the approved suppliers can modify the exhaust barrel in order to meet appropriate ASME pressure vessel codes that accommodate the high temperature and pressure conditions of this 1R test method. Drawings of the permitted modifications are located with Gaspar, Inc.⁹

6.2.2.2 Install a restriction valve downstream from the exhaust barrel. The distance between the valve and barrel is not specified. The location of the exhaust thermocouple is shown in **Annex A2**. Measure the exhaust pressure at the exhaust barrel shown in **Annex A2**.

6.2.2.3 Use feedback-equipped controls to maintain the exhaust gases at the pressure specified in **Annex A10**.

6.2.3 *Fuel System*—The fuel system schematic is shown in **Annex A5**. The ECM controls fuel injection timing at 6° BTC. Measure the fuel rate using a Micro Motion device scaled to the 1R operation range specified in **Annex A10**.^{14,12} Use the day tank specified in **Annex A5**. Measure fuel temperature at the fuel filter base as shown in **Annex A2** and control it using the cell facility feedback system. Use the required fuel heat exchanger(s) and arrange them as specified in **Annex A5**. Use the Fisher regulator specified in **Annex A5**.

6.2.4 *Oil Consumption System*—Use an oil scale system to accurately measure oil consumption (see **Annex A6**). The oil scale system shall have a resolution as listed in **Annex A2**. Use flexible hoses similar to Aeroquip flexible hose, FC352-08, to-and-from the oil scale reservoir to eliminate measurement errors.^{15,12} Use No. 5 TFE-fluorocarbon, steel-braided hoses to and from the oil scale pumps. The hose length to-and-from the oil scale cart shall not exceed 2700 mm. Use the special oil pan adapter described in **Annex A6**. The flow rates for the oil consumption oil scale pumps shall be (23.6 to 24.9) kg/h for the oil being pumped from the oil pan to the oil scale, and (16.3 to 17.7) kg/h for the oil being pumped from the oil scale to the oil pan. See **Annex A6** for the procedure to verify these flow rates.

6.2.5 *Engine Oil System*—A schematic of the oil system is shown in **Annex A6**. Measure oil pressure at the engine oil manifold (see **Annex A2**). An engine oil pressure sensor transmits a signal to the ECM that maintains oil pressure at 415 kPa. The ECM transmits a signal to an engine-mounted Mamac air pressure controller. The Mamac modulates the facility air pressure of 280 kPa to levels that vary between (0 to 140) kPa and directs it to the normally closed Johnson Controls relief valve. Because the engine oil pressure sensor calibration may vary from the cell data acquisition transducer, vary the oil pressure adjust signal to the ECM to maintain the oil pressure at the test specifications. See the Electronic Installation and Operation manual for additional information. The ECM maintains the oil pressure regardless of engine speed. Measure the oil temperatures at locations shown in **Annex A2**. Install 1Y4021 gaskets on each side of the 1Y3661 oil pump bypass lock nut to prevent oil aeration (see **Annex**

⁹ Cimino Machinery Corp., 5958 South Central Ave, Chicago, IL 60638. Gaspar Inc., 4106 Mahoning Rd. N.E., Canton, OH 44705. M.L. Wyrick Welding, 2301 Zanderson Highway 16 N, Jourdanon, TX 78026.

¹⁰ Crankcase Paint Primer: BASF Coating and Colorant Div., P.O. Box 1297, Morganton, NC 28655. Primer #A123590 & BASF Part #U27YD005. Yellow CAT Primer Part #IE2083A.

¹¹ The sole source of supply of the apparatus known to the committee at this time is Watlow Air Heaters, Chicago, IL.

¹² If you are aware of alternative suppliers, please provide this information to ASTM International Headquarters. Your comments will receive careful consideration at a meeting of the responsible technical committee,¹ which you may attend.

¹³ The sole source of supply of the apparatus known to the committee at this time is Sierra Instruments, Inc., 5 Harris Court, Monterey, CA 93940.

¹⁴ The sole source of supply of the apparatus known to the committee at this time is Micro Motion, Inc. 7070 Winchester Circle, Boulder, CO 80301.

¹⁵ The sole source of supply of the apparatus known to the committee at this time is Aeroquip Industrial Div, 1225 W. Main Street, Van Wert, OH 45891.

A6). When a new pump is installed, begin adjustment of the pressure relief plug with 43.7 mm of thread exposed as shown in **Annex A6**. Optional oil pressure sensor lines may be installed at the oil filter block as shown in **Fig. A2.6** for measuring the differential pressure across the oil filter.

6.2.5.1 *Oil Heating System*—Use an external oil heating system provided by the test facility to maintain the engine oil manifold temperature specified in **Annex A10**. An example system is shown in **Appendix X1**. A special 1Y3908 oil cooler bonnet has been designed to allow separate fluids to the engine coolant tower (see **Annex A6**). Plug the 1Y3660 oil cooler adapter and 1Y3908 heat exchanger bonnet as shown in **Annex A6**. Use Paratherm NF for the heating fluid.^{16,12} The temperature of the Paratherm NF is measured by the thermocouple shown in **Annex A2**. An additional heat exchanger may be installed to provide cooling capability, if necessary, to maintain test conditions.

6.2.5.2 *Oil Sample Valve*—Refer to **Annex A2** for the installation location and component makeup of the oil sample valve. Use of alternative equivalent components for the sample valve is permitted.

6.2.6 *Engine Coolant System*—The coolant system schematic is shown in **Annex A3**. Pressurize the coolant tower with compressed air as specified in **Annex A3** to ensure water does not boil out of the antifreeze mixture. Control the coolant temperature out of the engine using a cell facility feedback system. Use a 1Y3898 Johnson Controls valve or equivalent fail-open valve to regulate the coolant temperature out of the engine as shown by the schematic in **Annex A3**. If the 1Y3898 Johnson valve is used, supply facility air pressure at 280 kPa to the controller that regulates air pressure to the valve at (0 to 140) kPa. Install a feedback-equipped control system to pneumatically adjust the valve. Remove the 1Y3832 hose originally supplied with the engine and install a sight glass using the components shown in **Annex A3**. Use Caterpillar part no. 9X2378 replacement bulk hose for coolant hoses in the Caterpillar 1Y3700 engine.

6.2.7 *Engine Instrumentation*—Use feedback-equipped systems to control the engine operating temperatures, pressures, and flow rates. Measure the engine operating conditions at the locations shown in **Annex A2**. For temperature measurements, use thermocouples 1Y468 (intake air), 1Y467 (engine exhaust) and 1Y466 (fluids-water, oil and fuel) or equivalent thermocouples as specified in **Annex A2**. Install thermocouples with the tips at midstream. The thermocouple insertion depths listed in **Annex A2** are approximate depending on the mountings or fittings used. Instrument measurement and reporting resolutions are shown in **Annex A2**.

6.2.8 Use a dynamometer with feedback control to maintain engine torque and speed. Use a starting system capable of at least 136 N·m breakaway torque and 102 N·m sustained torque at 200 r/min.

6.2.9 *Blowby*—Measure engine blowby down stream of the engine breather housing by measuring the delta pressure across an orifice or an equivalent device.

6.2.10 *Crankcase Pressure*—Measure crankcase pressure at the location shown in **Annex A2**.

NOTE 1—The crankcase pressure is above atmospheric pressure with this engine.

6.3 Obtain information concerning the test engine, engine electronics system, new engine parts, replacement parts and permissible substitution or replacement parts from Caterpillar, Inc.

6.4 Engine and parts warranty information can be found in **Annex A1**. Use the form listed in **Annex A12** for returning defective parts.

7. Reagents and Materials

7.1 *Purity of Reagents*—Use reagent grade chemicals in all tests. Unless otherwise indicated, it is intended that all reagents conform to the specifications of the Committee on Analytical Reagents of the American Chemical Society where such specifications are available.¹⁷ Other grades may be used, provided it is first ascertained that the reagent is of sufficiently high purity to permit its use without lessening the accuracy of the determination.

7.2 *Diesel Piston Rating Booth*, as described by ASTM Deposit Rating Manual 20.

7.3 *Diesel Piston Rating Lamp*, as described by ASTM Deposit Rating Manual 20.

7.4 *Engine Coolant*—Use a mixture of 50 % mineral-free water and 50 % Caterpillar brand coolant (P/N 8C684 for 3.8 L concentrated or P/N 101-2845 for 208 L drum already premixed) for engine coolant. Mineral-free water is defined as water having a mineral content no higher than 34.2 mg/kg total dissolved solids. The coolant mixture may be reused for 3 test starts or up to 1600 h. Keep the mixture at a 50-50 ratio as determined by using either Caterpillar testers 5P3514 or 5PO957 or an equivalent tester. Keep the coolant mixture contamination free. Total solids shall remain below 5000 mg/kg. Keep the additive level correct using Caterpillar test kit P/N 8T5296.

7.5 *Lead Shot*, commercial grade, approximately 5 mm in diameter.

7.6 *Light Grease*.

7.7 *Mobil EF-411*, to be obtained for engine assembly and calibration of the oil scale pump flow rates.^{18,12}

7.8 *Paratherm NF*, to be obtained from Paratherm and used as the fluid to heat the engine oil.³

7.9 *Pentane (Solvent)*, Purity >99 %, high-performance liquid chromatography grade.

¹⁷ ACS Reagent Chemicals, Specifications and Procedures for Reagents and Standard-Grade Reference Materials, American Chemical Society, Washington, DC. For suggestions on the testing of reagents not listed by the American Chemical Society, see *Analar Standards for Laboratory Chemicals*, BDH Ltd., Poole, Dorset, U.K., and the *United States Pharmacopeia and National Formulary*, U.S. Pharmacopeial Convention, Inc. (USPC), Rockville, MD.

¹⁸ The sole source of supply of Mobil EF-411 known to the committee at this time is Golden West Oil Co., 3010 Aniol St, San Antonio, TX 78219.

¹⁶ The sole source of supply of the apparatus known to the committee at this time is Paratherm NF Oil, Conshohocken, PA 19428.

7.10 *Reference Oil*, to be obtained from the TMC for calibration of the test stand.

7.11 *Sodium Bisulfate* (NaHSO₄), commercial grade.

7.12 *Solvent*—Use only mineral spirits meeting the requirements of Specification **D235**, Type II, Class C for Aromatic Content ((0 to 2) vol %), Flash Point (61 °C, min) and Color (not darker than +25 on Saybolt Scale or 25 on Pt-Co Scale). (**Warning**—Combustible. Health hazard.) Obtain a Certificate of Analysis for each batch of solvent from the supplier.

7.13 *Test Fuel*—The specified test fuel is Chevron Phillips PC-9-HS Reference Diesel Fuel.^{19,12} The specification requirements are shown in **Annex A7**.

7.14 *Test Oil*—The total amount of oil needed for each test is approximately 42 L.

7.15 *Trisodium Phosphate* (Na₃PO₄), commercial grade.

7.16 *5.4000 in. Ring Bore Standard Class Z Master*.^{20,12}

8. Oil Samples and Additions

8.1 Take a 60 mL purge sample and a 120 mL sample at (36, 144, 252, 360, 432, 504) h. Take a 60 mL purge sample and a 30 mL sample at (72, 108, 180, 216, 288, 324, 396, 468) h. Analyze the (36, 144, 252, 360, 432, 504) h samples for (100 and 40) °C viscosity by Test Method **D445**, BN by Test Method **D4739**, AN by Test Method **D664**, wear metals Al, Cr, Cu, Fe, Pb, Si by Test Method **D5185**, and differential IR O₂ using the peak-area method 5. Analyze the (36, 360, 504) h samples for fuel dilution by Test Method **D3524**. Analyze the (360, 432, 504) h samples for TGA soot by Annex A4 of Test Method **D5967**. The (72, 108, 180, 216, 288, 324, 396, 468) h samples are for optional analysis such as wear metals for mechanical problems.

8.2 Add new oil as computed in the worksheet shown in **Annex A6**.

9. Preparation of Apparatus

9.1 *General Engine Assembly Practices*—As a part of good laboratory practice, inspect all components and assemblies that are exposed when the engine is disassembled and record the information for future reference. Inspect valve train components, bearings, journals, housings, seals and gaskets, and so forth and replace as needed. Assemble the engine with components and bolt torques as specified in the 1Y3700 engine Service Manual (see **Annex A8** for a partial list). It is the intent of this procedure for all engine assemblies and adjustments to be targeted to the mean of the specified values. Clean and lubricate the components in keeping with good assembly practices. Keep airborne dirt and debris to a minimum in the assembly area. Maintain standard engine assembly techniques and practices (such as staggering piston ring gap positions, and so forth).

¹⁹ The sole source of supply of the apparatus known to the committee at this time is Chevron Phillips Chemical Company LP, 10001 Six Pines Dr., Suite 4036B, The Woodlands, TX 77387-4910, www.cpcchem.com.

²⁰ The sole source of supply of the apparatus known to the committee at this time is Morse-Hemco, 457 Douglas Ave., Holland, MI 49423.

9.2 *Complete Engine Inspection*—Perform a complete engine inspection prior to the first calibration test scheduled after 15 000 h of test time. Ensure that wearing surfaces such as main bearings and journals, rod bearings and journals, camshaft bearings, valve train components, fuel system components, and so forth all are within manufacturer's specifications. Refer to the 1Y3700 Service Manual for disassembly, assembly, inspections, and specifications. Paint crankcases, as necessary, with either Caterpillar yellow primer or red Glyptal.¹⁰

9.3 *Copper Components*—It is recommended that anytime a copper part is replaced, run an engine test until two consecutive 12 h periods show a stable copper level in the used oil. Do not use rocker arms with a package date earlier than January 2000.

9.4 *Engine Lubricant System Flush*—Flush the engine of used oil before every test. **Annex A9** shows the Engine Flush Procedure and Apparatus. A flushing instruction sheet shown in **Table A9.1** gives the step-by-step process required for flushing. The 1Y3700 engine includes five flushing nozzles in the crankcase and front cover (see **Annex A9**). These nozzles are piped in parallel with the 1Y3935 filter flushing adapter (or equivalent) from a laboratory-provided manifold that pressurizes fluids supplied by a flush cart (see **Appendix X1**). To increase flushing pressure, the oil pan may be plumbed as shown in **Appendix X1**. Seal the gear train housing during flush with a 1Y3917 round plug with a 117-8801 O-ring as shown in **Annex A9**. Seal the crankcase using a 1Y3979 block flush cover with an internal bleed passage for the cam oil supply. Bolt a 1Y3980 plastic jet aiming fixture to the flush cover that is also used for flushing (see **Annex A9**). Modify the crankcase side covers as shown in **Annex A9** to accommodate the flushing wand for a thorough flushing of the crankcase. If the test oil is not available at engine assembly, Mobil EF411 oil may be substituted.

9.5 *Engine Piston Cooling Jet*—Use cooling jet part no. 1Y4011 and bolt 1Y4010. The piston cooling jets are flow-checked at the supplier and serialized to ensure proper performance, but the rod clearances are minimal, which may result in jet movement during assembly. Verify proper jet flow positioning using test oil or EF-411 before each test with the 1Y3980 plastic jet aiming fixture and 415 kPa oil pressure to the manifold. Record the cooling jet serial number.

9.6 *Engine Measurements and Inspections*—Measure and inspect the engine components prior to each test. Refer to the 1Y3700 Service Manual for information concerning component reusability and assembly not found in this procedure. The part numbers of components that need replacing are found in the 1Y3700 Parts Manual. Record the crankshaft angles at the specified maximum injector lift, exhaust, and intake maximum lift before each test using the reference listed in **Annex A8**. Record component part numbers and serial numbers and other required measurements as shown in the test report. Inspect and reuse the rocker arm roller followers and camshaft lobe surfaces based on Caterpillar Service Publication SEBF8256.²

9.7 *Cylinder Head*—A reconditioned head is required for each test. Measurements after reconditioning shall be within specifications as shown in the 1Y3700 Service Manual. Do not

swap the cylinder head/jug assembly from test stand-to-test stand. Use the head/jug assembly used to calibrate the stand for all non-reference oil testing in that stand. In the event of a cylinder head/jug failure during the calibration period, a cylinder head/jug used on a successful 1R calibration attempt within the past two years may be used without re-calibration. **Annex A8** shows the cylinder head nut torque sequence. Use Caterpillar part no. 175-7523-J for the inner spring, 175-7526-J for the outer spring and 186-2001 for the rotocoil.

9.8 *Valve Guide Bushings*—Clean the valve guide bushings with a solvent and bristle brush prior to assembly. Lubricate the bushings and valve stems with Mobil EF-411 prior to assembly. See the 1Y3700 Service Manual for guide reusability specifications. Install new valve guide seals for each test.

9.9 *Fuel Injector*—Remove the fuel injector from the cylinder head before reconditioning commences. Refer to the 1Y3700 Service Manual for removal and assembly. Return defective fuel injectors to Caterpillar for warranty and failure-mode testing using the form listed in **Annex A12**.

9.10 *Piston and Rings*—Use a new piston (1Y4016 iron crown, 1Y4015 aluminum skirt) and new rings (1Y4014, 1Y4013, 1Y4012) for each test. Clean all three rings with pentane and a lint-free cotton towel. Measure the ring side clearances and ring end gaps for all three rings (see **Annex A8**). Keystone ring side clearance measurements require the ring to be confined in a dedicated slotted liner (see **Appendix XI**) or a 137.16 mm ring gauge.^{20,12} Measure the side clearances using four feeler gauges of equal width and 0.01 mm graduations at 90° intervals around the piston. Measure the rectangular ring side clearance this way as well. Measure the minimum side clearance as specified in ASTM Deposit Rating Manual 20. Record the measurements for these parts before and after each test. Compare the measurements before the test and after the test to determine the amount of wear. Assemble the piston with the part number toward the camshaft.

9.11 *Cylinder Liner*—Use a new 1Y3805 or 1Y3997 cylinder liner for each test. After removing the protective oil/grease with solvent, clean the liner bore with a hot tap water and soap solution, then rinse with hot tap water.

9.11.1 Measure and record the liner surface finish. The surface finish specification shown in **Fig. A8.3** does not apply to the 1Y3997 liner.

9.11.2 Oil the liner bore with only Mobil EF-411. Assemble the cylinder liner, block and head with the torque specification shown in the 1Y3700 Service Manual or **Annex A8**.

9.11.3 Measure the liner with a dial bore gauge to ensure that the out-of-round and taper conditions are within specified tolerances measured at seven intervals as shown in **Annex A8**.

9.11.4 Measure the cylinder liner projection using the modified indicator shown in **Annex A8**.

9.11.5 Torque the cylinder liner support ring using the procedure shown in **Annex A8**.

9.12 *Compression Ratio*—Before starting each test, measure the piston-to-head clearance to ensure the proper compression ratio is used. Determine this dimension by using lead balls of approximately 3.5 mm in diameter. Locate four lead balls on the top of the piston at 90° intervals on the major and minor

piston diameters. Hold them in place with light grease. With the piston near the top of the stroke, install the head and block assembly and torque to specifications. Turn the engine over top center by hand to compress the lead balls then remove the head and block assembly and measure the thickness of the lead balls to obtain the average piston-to-head clearance. The piston-to-head clearance specification is (1.62 ± 0.07) mm. Use multiple 1Y3817 block gaskets to adjust the clearance. If the piston-to-head measurement exceeds the tolerance specification, check the crankshaft main and rod journals, connecting rod and main bearings, and piston pin and rod bushing for excessive wear. The specified compression ratio for the 1Y3700 engine is 16.2:1.

9.13 *Engine Timing*—Use ECM EPROM part no. 169-5028 with a date code of 10/98. The engine ECM sets desired fuel injection timing to 6° (BTC). Record this timing using the Engine Technician Service Tool. Mechanically time the actual engine components as shown in **Annex A8**. Install the electronic sensors as shown in the Electronic Installation and Operation manual. Correctly assemble both the mechanical and electrical systems to produce the desired fuel timing.

9.14 *Engine Coolant System Cleaning Procedure*—Clean the coolant system when visual inspections show the presence of any oil, grease, mineral deposits, or rust following the procedure listed in **Annex A3**.

9.15 After the engine components have been prepared and assembled, perform the following:

9.15.1 Fill the crankcase with (5800 ± 50) g of test oil.

9.15.2 Install a new 1R0713 oil filter.

9.15.3 Fill the coolant system with coolant specified in Section 7.

9.15.4 Ensure the facility coolant to the engine heat exchanger is operational.

9.15.5 Pressurize the fuel system to remove air, then return the system to a non-pressurized state before starting engine.

9.15.6 Ensure all other systems and facilities are operational before starting the engine break-in.

10. Calibration and Standardization

10.1 *Test Cell Instrumentation*—Calibrate all facility read-out instrumentation used for the test immediately prior to stand calibration. Instrumentation calibration following a failed or invalid test is at the discretion of the test laboratory, or as directed by the TMC. Refer to **Annex A2** for calibration tolerances and allowable system time constants.

10.2 *Instrumentation Standards*—Calibrate all temperature, pressure, flow and speed measurement standards on a yearly basis. The calibration of all standards shall be traceable to a national bureau of standards. Maintain all calibration records for a minimum of two years.

10.3 *Coolant Flow*—Calibrate the coolant flow rate as follows: (1) calibrate the differential pressure transducer as outlined in 10.1 and 10.2, and (2) replace the Barco venturi every two years or calibrate the Barco venturi to a

standard.^{21,12} Use the following relationships as conversion factors from the differential pressure across the Barco venturi to determine L/min:

$$0.75 \text{ kPa} = 24.3 \text{ L/min,}$$

$$1.76 \text{ kPa} = 37.8 \text{ L/min, and}$$

7 kPa = 75.7 L/min, or use the equation:

$$L/\text{min} = \sqrt{\Delta P} 28.848 - 0.5927 \quad (1)$$

where ΔP is measured in kilopascals.

10.4 Fuel Injectors—The fuel injectors are calibrated during the manufacturing process. These fuel injectors can not be re-calibrated in the usual manner and require special test equipment to ensure proper flow, timing response, and spray patterns. Therefore, replace the fuel injector at the start of a calibration test or calibration series. If the fuel injector is replaced on a calibrated stand, re-calibration is not required.

10.5 Air Flow—Install the Sierra Model 780 airflow meter to measure intake airflow. See **6.2.1.5** for calibration information specific to this test method. Measure the intake airflow during the break-in of every calibration test. Record the last value recorded during Step 5 of the break-in as shown in **Annex A10**.

10.6 Intake Air Barrel—Prior to each stand calibration test, inspect the intake air barrel for rust or debris. This may be done through either of the pipe flanges using a bore scope or some other optical means.

10.7 Fuel Filter—Change the fuel filter before every calibration test.

10.8 Oil Scale Flow Rates—Verify the oil scale flow rates before the start of every calibration test using the procedure listed in **Annex A6**.

10.9 Test Stand Calibration—Use a blind calibration oil from the TMC to calibrate the engine stand. A stand calibration test is required every twelve months. The calibration period begins on the end date of the acceptable calibration test. A test stand is considered calibrated when the test results are within the acceptability limits as published by TMC in the Lubricant Test Monitoring System (LTMS) manual²² and the test is operationally valid. The TMC may request stand checks on calibration tests that fail to meet acceptability limits. If the calibration test is operationally valid, send the piston to another calibrated laboratory for a referee rating. In order for the test to be considered valid, report the test data to the TMC within seven days of end-of-test (EOT). The TMC issues the testing laboratory a control chart analysis for each calibration test (see **Fig. A7.2**). The test stand is not considered calibrated if the calibration test was invalid or uninterpretable. Start any non-reference test prior to the expiration of the calibration period.

10.9.1 Re-calibration Requirements—The calibration status is void if one or more of the following occur:

10.9.1.1 The engine crankcase requires replacing,

10.9.1.2 The engine crankshaft requires replacing or regrinding,

10.9.1.3 The crankshaft is removed for any other purpose besides bearing replacement, and

10.9.1.4 The cylinder head or jug suffer a failure for any reason during the calibration period and a cylinder head/jug not meeting the requirements under **9.7** is used. All other engine components can be replaced at the discretion of the laboratory.

10.9.2 Guidelines for Adjustments to Calibration Periods—Reference oil test frequency may be adjusted for the following reasons:

10.9.2.1 Procedural Deviations—On occasions when a laboratory becomes aware of a significant deviation from the test method, such as might arise during an in-house review or a TMC inspection, the laboratory and the TMC shall agree on an appropriate course of action to remedy the deviation. This action may include the shortening of existing reference oil calibration periods.

10.9.2.2 Parts and Fuel Shortages—Under special circumstances, such as industry-wide parts or fuel shortages, the surveillance panel may direct the TMC to extend the time intervals between reference oil tests. These extensions shall not exceed one regular calibration period.

10.9.2.3 Reference Oil Test Data Flow—To ensure continuous severity and precision monitoring, calibration tests are conducted periodically throughout the year. There may be occasions when laboratories conduct a large portion of calibration tests in a short period of time. This could result in an unacceptably large time frame when very few calibration tests are conducted. The TMC can shorten or extend calibration periods as needed to provide a consistent flow of reference oil test data. Adjustments to calibration periods are made such that laboratories incur no net loss (or gain) in calibration status.

10.9.2.4 Special Use of the Reference Oil Calibration System—The surveillance panel has the option to use the reference oil system to evaluate changes that have potential impact on test severity and precision. This option is only taken when a program of donated tests is not feasible. The surveillance panel and the TMC shall develop a detailed plan for the test program. This plan requires all reference oil tests in the program to be completed as close to the same time as possible, so that no laboratory/stand calibration is left in an excessively long pending status. In order to maintain the integrity of the reference oil monitoring system, each reference oil test is conducted so as to be interpretable for stand calibration. To facilitate the required test scheduling, the surveillance panel may direct the TMC to lengthen and shorten reference oil calibration periods within laboratories such that the laboratories incur no net loss (or gain) in calibration status.

10.9.3 Donated Reference Oil Test Programs—The Surveillance Panel is charged with maintaining effective reference oil test severity and precision monitoring. During times of new parts introductions, new or re-blended reference oil additions, and procedural revisions, it may be necessary to evaluate the possible effects on severity and precision levels. The surveillance panel may choose to conduct a program of donated reference oil tests in those laboratories participating in the

²¹ The sole source of supply of the apparatus known to the committee at this time is Hyspan Precision Products, Inc., 1685 Brandywine Avenue, Chula Vista, CA 91911.

²² The LTMS method tracks the severity and precision of stand and laboratory test results. For a complete definition, refer to the LTMS manual available from ASTM Test Monitoring Center.²

monitoring system, in order to quantify the effect of a particular change on severity and precision. Typically, the surveillance panel requests its panel members to volunteer enough reference oil test results to create a robust data set. Broad laboratory participation is needed to provide a representative sampling of the industry. To ensure the quality of the data obtained, donated tests are conducted on calibrated test stands. The surveillance panel shall arrange an appropriate number of donated tests and ensure completion of the test program in a timely manner.

10.10 *Test Run Numbering*—Number each test to identify the test stand number and the test run number. Number all runs sequentially. Append repeat calibration runs with a letter that is also sequential (that is, number the first re-run of test 45 as 46A, the second as 47B, and so forth). Maintain the letter suffix sequencing for each calibration test until the calibration has been accepted. Increment the run number for any test start.

10.11 *Humidity Calibration Requirements*—The accuracy of the laboratory’s primary humidity measurement system shall be within ± 0.6 g of the humidity measuring chilled mirror dew point hygrometer or equivalent.

10.11.1 Calibrate the primary laboratory humidity measurement system within 48 h before the start of each stand calibration test or during the stand calibration test using a chilled mirror dew point hygrometer or equivalent with an accuracy of at least ± 0.55 °C at dew point of 24 °C.

10.11.2 The calibration consists of a series of paired comparison measurements between the primary system and the chilled mirror dew point hygrometer or equivalent. The comparison period lasts from 20 min to 2 h with measurements taken at 1 min to 6 min intervals, for a total of 20 paired measurements. The measurement interval should be appropriate for the time constant of the humidity measuring instruments.

10.11.3 Ensure that the flow rate is within the equipment manufacturer’s specification.

10.11.4 Take all measurements made with the dew point hygrometer or equivalent at atmospheric pressure and correct them to standard pressure conditions (101.12 kPa). Compute the difference between each pair of measurements and calculate the mean and standard deviation of the differences.

10.11.5 The absolute value of the mean difference shall not exceed 0.6 g and the standard deviation shall be less than or equal to 0.3 g. The primary humidity measurement system is deemed calibrated only if both of these requirements are met. If either of these requirements is not met, investigate the cause, make repairs, and recalibrate. Maintain the calibration data for a minimum of two years.

10.12 *Calibration of Piston Deposit Raters*—The ASTM Standardized Testing Deposit Rating Workshop trains piston deposit raters. Raters shall maintain rating expertise by attending the annual rating workshop. Each rater shall rate a minimum of six diesel pistons. If this schedule is not suitable to a particular rater or test laboratory, make alternative arrangements by contacting the TMC as soon as possible to have the rater calibrated.

10.12.1 Failure to attend a rating workshop results in the loss of calibration status for that rater.

11. Procedure

11.1 *Engine Break-in Procedure*—Open any drain taps at the low points of the combustion air system (if they are installed) during the start of the break-in and warm-ups, and following any shutdowns. The engine break-in and operational conditions are specified in **Annex A10**. The total break-in time is 85 min. During the break-in, fix all leaks and make adjustments to ensure proper engine operation. Record the ECM EPROM module part number and release date. After the break-in period and while the engine is hot, drain the oil from the crankcase, oil cooler, engine oil filter and weigh scale for 30 min. Then weigh (5800 ± 50) g of new test oil into the engine. Start the engine, warm it up, and operate it for 504 h at the test conditions specified in Step 5 of **Annex A10** with no oil changes. Turn on the oil scale pumps once the engine has reached the beginning of Step 5 of the warm-up sequence. Record the oil mass in the oil scale as the full mark at test hour 4. Throughout the test, record the oil scale reading at least once every 6 min. Count test time from the moment the warm-up time is completed. The oil sample frequency is described in Section 8. Do not remove the cylinder head, piston, or power assembly from the engine during a test.

11.1.1 Reinitialize engine timing calibration after the cam shaft/gear or cylinder head has been removed. See the electronic installation and operation manual. Complete this during the first step of the break-in.

11.2 *Cool-down Procedure*—Except for emergency (uncontrolled) stops, shut the engine down by operating it at conditions shown in Steps 4, 3, 2, and then 1 in **Annex A10**.

11.3 *Warm-up Procedure*—Use the same procedure used for engine break-in to warm-up the engine for all subsequent starts throughout the test.

11.4 *Shutdowns and Lost Time*—Record the test hour, date, and length of off test conditions for all occurrences. Record when the engine has early inspections or early test termination with the reasons for the occurrences. If the cool down procedure is not used, identify the shutdown as an Emergency Shutdown. A maximum of 125 h of off test conditions are allowed. If the engine shuts down, immediately stop the oil scale pumps. In the event of an emergency shutdown, leave the engine shut down for 2 h (or more) to allow complete engine cool down before restarting. In order to limit foreign matter entering the combustion chamber and to protect piston deposits, rotate the engine to top dead center (TDC) of the compression stroke during downtime.

11.5 *Periodic Measurements*—Record all engine conditions listed in Step 5 of **Annex A10** as a snapshot at least once every 6 min. Record humidity readings using the laboratory’s primary humidity measurement system. Correct the recorded humidity values to standard pressure conditions of 101.12 kPa. Record the fuel position as indicated by the Electronic Technician at test hours 36, 360, and 504.

11.6 *Engine Control Systems:*

11.6.1 *Engine Coolant*—Pressurize the coolant system to (35.0 ± 7) kPa as shown in **Annex A3** to ensure the water does not boil out of the antifreeze. Manually adjust the coolant flow

rate by turning the valve on top of the coolant tower to maintain the conditions specified in [Annex A10](#).

11.6.2 *Engine Fuel System*—Control the fuel rate by modifying the fuel limit adjusting the ECM using a facility controller that compares the actual fuel rate to the specified fuel rate listed in [Annex A10](#). See the Electronic Installation and Operation manual for more details. Manually adjust the Fisher regulator to control fuel pressure. Maintain the fuel pressure and temperature as specified in [Annex A10](#).

11.6.3 *Engine Oil Temperature*—Maintain the oil manifold temperature to test specifications as shown in [Annex A10](#). Do not allow the temperature of the Paratherm NF to exceed 165 °C at any time during break-in, warm-up or testing. Shut off the external oil heater (but not its circulating pump) the moment the engine goes to cool-down.

11.6.4 *Exhaust Pressure*—Control the exhaust pressure to the conditions shown in [Annex A10](#).

11.6.5 *Intake Air*—Filter, compress and humidify the inlet air to the conditions specified in [Annex A10](#). Heat (or cool, if necessary) the inlet air to the conditions in [Annex A10](#).

11.7 *Post-Test Procedures*—Remove the piston and ring assembly from the engine. Mark the location of the ring gaps on top of the piston.

11.7.1 *Piston Ring Side Clearances*—Measure the piston ring side clearances prior to removal of the rings to determine the level of deposit formation (see [Annex A8](#)). Align ring gaps to the EOT ring gap marks on the top of the piston. Do not force the feeler gauges between the ring and groove to disturb or remove the deposits.

11.7.2 *Piston Ratings*—Immerse the piston assembly in solvent and air-dry it prior to any rating. Process and measure the piston deposits according to the Modified ASTM Diesel Piston Rating Method described in ASTM Deposit Rating Manual 20 and modified by the directions listed in [Annex A11](#). Rate only two levels of carbon (heavy and light) on the second groove and all lands, and only one level of carbon (light) for the under-crown and cooling groove. Use a combined varnish rating method for the third groove, third land, fourth land, under-crown and cooling groove (see [Annex A11](#)). An example rating worksheet is shown in [Appendix X1](#). Another heavy-duty engine deposit rater shall verify all piston deposit ratings done by the testing laboratory. In special cases where another rater is not available, the rating may be verified by other qualified laboratory personnel. Record the initials of both the rater and the verifying rater.

11.7.2.1 *Referee Ratings*—The referee laboratory rates the entire piston. Wrap all pistons to be referee-rated in paper with desiccant chips. Then place them in plastic and seal before shipping to the referee laboratory. Report referee ratings to the TMC within 10 days of EOT for calibration tests. Referee-rate piston deposits for all non-reference tests reviewed by Caterpillar.

11.7.3 *Ring End Gap Increase*—Remove all carbon from the rings. If scraping of the rings is necessary, use only a wooden instrument or equivalent. Measure and record the ring end gaps.

11.7.4 *Cylinder Liner Wear*—Measure the wear at the front, rear, thrust and anti-thrust positions (four equally spaced positions) as described in the Mack T-10 Test Method.²

11.7.5 *Cylinder Liner Bore Polish*—Section the cylinder liner through the front and rear axis and measure the cylinder liner to determine the amount of bore polishing. Use the liner rating method listed in [Annex A11](#).

11.7.6 *Photographs*—Photograph the piston and rings showing the thrust, anti-thrust, front, rear, and under-crown positions (see [Appendix X1](#)). Place the rings on top of the piston to show ring gaps (thrust view) and 180° from gaps (anti-thrust view). Show the piston from the crown down to at least the bottom of the pin bore. Photograph the piston crown and skirt as one assembly. Photograph the bore inside diameter (ID) of the sectioned liner (see [Appendix X1](#)).

12. Calculation or Interpretation of Results

12.1 *Test Validity*—If a test was run for 504 h according to this test method declare the test valid. If a test was not run as specified by this test method, then the test is operationally invalid. Some examples of an invalid test are:

- 12.1.1 Use of non-specified hardware,
- 12.1.2 Use of non-specified assembly methods,
- 12.1.3 A test run whose downtime is greater than 125 h,
- 12.1.4 Potentially a test that has a Quality Index (QI) value for a controlled parameter below the threshold of zero (see DACA II Report²), and

12.1.5 If a test has greater than four consecutive hours without data acquisition on any controlled parameter.

12.2 A test with any control parameter QI value less than zero requires an engineering review to determine operational validity.

12.2.1 *Engineering Review*—Conduct an engineering review when a control parameter QI value is below zero. A typical engineering review involves investigation of the test data to determine the cause of the below zero QI. Other affected parameters may also be included in the engineering review. This can be helpful in determining if a real control problem existed and the possible extent to which it may have impacted the test. For example, a test runs with a low QI for fuel flow. An examination of the fuel flow data may show that the fuel flow data contains several over range values. At this point, an examination of the exhaust temperatures may help determine whether the instrumentation problem affected real fuel flow versus affecting only data acquisition.

12.2.1.1 For calibration tests, conduct the engineering review jointly with the TMC. For non-calibration tests, consultation with the TMC is available, but not required.

12.2.1.2 Determine operational validity based upon the engineering review, and summarize the decision in the comment section. It may be helpful to include any supporting documentation at the end of the test report. The final decision regarding operational validity rests with the laboratory.

12.3 Some examples of non-interpretible tests are:

12.3.1 If a test completes 504 h and the piston, rings, or liner exhibit distress, and

12.3.2 If the test is terminated prior to completing 504 h for reasons including purchaser request, excessive oil

consumption, or piston, ring, or liner distress then consider the test non-interpretable.

12.4 *Calculations*—Use the same set of data for all calculations and graphs in the test report.

12.4.1 *Quality Index*—Calculate and plot the QI according to the instructions in **Annex A2**.

12.4.2 *Oil Consumption*—Calculate oil consumption in grams per hour over 36 h intervals. Delete the first 4 h of readings after an oil addition or shutdown from the linear regression. The linear regression technique is shown in **Annex A6**. Calculate the overall average oil consumption, the initial average oil consumption and EOT average oil consumption. The beginning of test oil consumption is the average of the 36 h periods from test hours 0 to 252; i.e., (36, 72, 108, 144, 180, 216, 252) h. The EOT average oil consumption is the average of the (468 and 504) h data points for a full-length test or for a short-term test it is the average of the last two data points from the oil consumption graph. Calculate the difference between the EOT and beginning of test oil consumption.

12.4.2.1 For a 36 h period including a shutdown, calculate the oil consumption as follows:

12.4.2.2 Do not include the first 4 h oil mass readings after a shutdown in the linear regression.

12.4.2.3 Calculate the linear regression for the period before the shutdown.

12.4.2.4 Calculate the linear regression for the period after the shutdown.

12.4.2.5 Calculate a time-weighted average from both regressions to obtain the oil consumption for that 36 h period. For example, a test experiences a 7 h shutdown at test hour twenty. The slope for the first 16 h period (hour 4 to 20) is 10.7 g/h, and the slope for the second 12 h period (hour 24 to 36) is 2.1 g/h. The weighted average is calculated as follows:

$$\text{Weighted Average} = \frac{(10.7 \text{ g/h})(16 \text{ h}) + (2.1 \text{ g/h})(12 \text{ h})}{16 \text{ h} + 12 \text{ h}} \quad (2)$$

13. Report

13.1 *Report Forms and Data Dictionary*—For reference oil tests, the standardized report form set and data dictionary for reporting test results and for summarizing the operational data are required. The test report forms and data dictionary are available at the TMC website and not included in this test method. All changes to the report forms and data dictionary are under the control of the Surveillance Panel for the test method.

TABLE 1 1R Reference Oil Precision Data

NOTE 1—These statistics are based on results obtained on Test Monitoring Center reference oils between July 4, 2001 and Feb. 13, 2004.

Test Parameter	S _{i,p.}	i.p.	S _R	R
TGC—top groove carbon, demerits	8.86	24.81	8.86	24.81
WD—weighted piston deposits, demerits	26.2	73.4	26.2	73.4
TLC—top land carbon, demerits	6.82	19.10	6.82	19.10
BTOC—beginning of test oil consumption	1.12	3.14	1.23	3.44
ETOC—end of test oil consumption	1.25	3.50	1.36	3.81

S_{i,p.} = Standard deviation for intermediate precision
 i.p. = Intermediate precision
 S_R = Standard deviation for reproducibility
 R = Reproducibility

Test report forms should closely resemble those located at the TMC. Report values for all the field names listed in the report forms. Some fields may be blank for short-term tests. Report all deposits, wear, and engine operational data as shown in the test report. The data dictionary defines the field lengths, decimal size, data type, units and format for the field names listed in the test report forms.

13.2 *Test Validity*—Document on the first sheet of the test report whether the test is Valid, Invalid, or Non-interpretable. For a valid stand calibration run, report the test data to TMC for inclusion of the test data in the operationally valid database and determine statistical validity using the LTMS method.²² For an invalid or non-interpretable stand calibration run, report the test data to TMC with comments describing why the test is considered invalid or non-interpretable. TMC does not include the test data in the operationally valid database. All operationally invalid and non-interpretable calibration tests are reported by the TMC to the ASTM Single Cylinder Diesel Surveillance Panel in periodic testing summaries.

NOTE 2—For a valid ACC Registered Oil Test, report the data to Registration Systems, Inc. (RSI).²³ For an invalid or non-interpretable ACC Registered Oil Test, report the test data to RSI with supporting comments describing why the test is considered invalid or non-interpretable.

NOTE 3—When non-calibration oil tests are presented to Caterpillar for review, include the data from all tests that were registered with RSI as part of the program.

13.3 Report Specifics:

13.3.1 If more than one fuel batch is used, report the fuel batch analysis that is most representative of the fuel in the tank.

13.3.2 Report any causes for any missing or bad test data in the comment section of Form 8. If any alternative data acquisition method is used, document it in the comment section of Form 8.

13.3.3 If a calibration period is extended beyond the normal one year period, make a note in the comment section of Form 8 and attach a written confirmation from the TMC to the test report.

13.3.4 For calibration tests, list the outcome of previous failed or invalid calibration runs in the comment section of Form 8.

13.3.5 Include the fuel analysis provided by the fuel supplier as Form 15. For calibration tests, include a copy of the TMC control chart analysis as Form 18.

NOTE 4—It is recommended that test purchasers include the form shown in **Fig. X1.8** as Form 18 when presenting the test results against specification limits, such as those in Specification **D4485** or military specifications.

14. Precision and Bias

14.1 *Precision*—Test precision is established on the basis of operationally valid reference oil test results monitored by the ASTM Test Monitoring Center. The data are reviewed semi-annually by the Single-Cylinder Diesel Surveillance Panel. Contact the ASTM TMC for current industry data.

14.1.1 **Table 1** summarizes reference oil intermediate precision and reproducibility of the test. The tabulated values are

²³ Registration Systems, Inc., ACC Monitoring Agency, 4139 Gardendale, Suite 205, San Antonio, TX 78229.

current as of Feb. 1, 2005. The Surveillance Panel updates these values as necessary.

14.1.2 *Intermediate Precision Conditions*—Conditions where test results are obtained with the same test method using the same test oil, with changing conditions such as operators, measuring equipment, test stands, test engines, and time.

NOTE 5—Intermediate precision is the appropriate term for this test method rather than repeatability which defines more rigorous within-laboratory conditions.

14.1.2.1 *Intermediate Precision Limit (i.p.)*—The difference between two results obtained under intermediate precision conditions that would in the long run, in the normal and correct conduct of the test method, exceed the values shown in **Table 1** in only one case in twenty. When only a single test result is available, the Intermediate Precision Limit can be used to calculate a range (test result \pm Intermediate Precision Limit) outside of which a second test result would be expected to fall about one time in twenty.

14.1.3 *Reproducibility Conditions*—Conditions where two test results are obtained with the same test method using the

same test oil in different laboratories with different operators using different equipment.

14.1.3.1 *Reproducibility (R)*—The difference between results obtained under reproducibility conditions that would, in the long run, in the normal and correct conduct of the test method, exceed the values in **Table 1** in only one case in twenty. When only a single test result is available, the Reproducibility Limit can be used to calculate a range (test result \pm Reproducibility Limit) outside of which a second test result would be expected to fall about one time in twenty.

14.2 *Bias*—Bias is determined by applying an accepted statistical technique to reference oil test results, and when a significant bias is determined, a severity adjustment is permitted for non-reference oil test results (see TMC Memo 94-200, Lubricant Test Monitoring System document for details²).

15. Keywords

15.1 Caterpillar 1R test procedure; oil consumption; piston deposits; single cylinder diesel oil test

ANNEXES

(Mandatory Information)

A1. ENGINE AND PARTS WARRANTY

A1.1 Engine Warranty

A1.1.1 Caterpillar Inc. warrants single cylinder test engines sold by it to be free from defects in material and workmanship for a period of twelve months starting from the date of delivery to the first user. If a defect in material or workmanship is found during the warranty period, Caterpillar will provide the replacement parts to be installed by the user. There will be no charge to the user for parts furnished by Caterpillar. User at its own expense, shall return all defective parts to Caterpillar at Caterpillar's request. User will be responsible for giving Caterpillar timely notice of a warranty failure. User will also be responsible for labor costs and any applicable local taxes. Caterpillar is not responsible for failures resulting from abuse, neglect, or improper repair, or a combination thereof. **This warranty is expressly in lieu of any other warranties, expressed or implied, including any warranty of merchantability or fitness for particular purpose. Remedies under this warranty are limited to the provision of parts as specified herein. Caterpillar is not responsible for incidental or consequential damages.**

A1.2 Engine Parts Warranty

A1.2.1 All parts for the 1Y3700 engine which are nonconforming by reason of faulty manufacture should be discussed with Engine System Technology Development (ESTD).

A1.2.1.1 The Test Labs should contact ESTD when they believe a part is nonconforming.

A1.2.1.2 ESTD will determine if they want the part returned, or provide warranty without viewing the part.

A1.2.1.3 If ESTD determines that the part is nonconforming without viewing the part, the test labs will be asked to return the part to their Caterpillar dealer. ESTD will contact the dealer and let them know the part is coming and to provide warranty for it.

A1.2.1.4 If ESTD wants to view the part, they will issue a Return Goods Authorization Number (RGA) to the test laboratory. The laboratory will fill out the Form shown in **Annex A9** and send the part and the form to Caterpillar Inc.²⁴ The test labs should fax a copy of the RGA Claim Form to Caterpillar Inc.²⁴

A1.2.1.5 If ESTD determines that the part is nonconforming, they will contact the dealer for the test laboratory and have the dealer provide warranty.

A1.2.1.6 A sample of the RGA Claim Form is shown in **Annex A9** and should include: return goods authorization number, part name, hours on the part, part number, quantity, engine serial number, date purchased, test laboratory that purchased the part and contact person's name, phone, fax, and address, dealer's name that sold the part, and measurements or photos, or both, to document the nonconformance.

²⁴ Caterpillar Inc., Tech Center Division, Bldg. L, Test Wing 4 – Rm 406, 14009 Old Galena Rd., Mossville, IL 61552. Attn: Dwayne Tharp.

A2. INSTRUMENT LOCATIONS, MEASUREMENTS AND CALCULATIONS

A2.1 Requirements for the Quality Index (QI) Calculation

A2.1.1 Round the recorded values in accordance with the specifications listed in Table A2.5.

TABLE A2.1 Instrument Locations

Parameter	Data Acquisition and Control	Engine Computer Sensors
Cam Speed and Timing Sensor		A
Crankshaft Speed and Timing Sensor ^A		B ^A
Coolant Pressure to Jug	1	
Coolant Temperature to Jug	2	
Oil Temperature to Cooler	3	
Atmospheric Pressure		C ^B
Crankcase Pressure	4	D ^B
Facility Air Pressure to Cooling Tower	5	
Oil Manifold Temperature	6	E ^B
Oil Sampling Valve	7	
Oil Manifold Pressure	8	F
Coolant Temperature from Engine	9	H ^B
Coolant Pressure from Engine		G ^B
Coolant Flow Barco Delta Pressure	10	
Air Inlet Manifold Pressure	Fig. A2.8	I ^B
Air Inlet Manifold Temperature	11	
Fuel Temperature from Filter	Fig. A2.4 - Z	
Fuel Pressure from Head	Fig. A2.4 - 13	
Fuel Flow Rate	(At Micro Motion)	
Exhaust Manifold Temperature	Fig. A2.3 - 14	Fig. A2.3 - J ^B
Exhaust Manifold Pressure	Fig. A2.7	
Humidity	Fig. A4.1	
Air Flow Rate	Fig. A4.1	
External Heating Oil Temperature	Fig. A2.5	
Oil Filter Inlet Pressure	Fig. A2.6 ^B	
Oil Filter Outlet Pressure	Fig. A2.6 ^B	

^A Connect for timing calibration only.
^B Optional.

TABLE A2.2 Recommended Thermocouple Diameters, Lengths and Immersion Depths^A

Location	Diameter, mm	Length, mm	Depth, ± 3 mm
Oil to Manifold	3.2	150 max	22
Oil to Cooler	3.2	150 max	27
External Heating Oil	3.2	150 max	27
Coolant In	6.4	150 max	40
Coolant Out	6.4	150 max	26
Inlet Air	6.4	150 max	57
Exhaust	6.4	150 max	67
Fuel	6.4	150 max	34

^A Chosen thermocouples shall meet the system time response shown in Table A2.4.

TABLE A2.3 Calibration Tolerances

Parameters	Tolerance
Torque	10 N-m
Fuel Flow Rate	0.4 g/min
Air Flow Rate	± 2% of reading from (10-100) % of calibrated range; ± 0.5 % of FS below 10 % of calibrated range
Humidity	Listed in this Test Method
Temperatures	
	°C
Fuel at Filter	0.5
Coolant to Jug	0.5
Coolant from Head	0.5
Oil to Cooler	0.5
Oil Manifold	0.5
External Heating Oil	0.5
Inlet Air at Manifold	0.5
Exhaust at Manifold	1.0
Pressures	
	kPa
Fuel from Head	0.7
Coolant to Jug	0.7
Oil Manifold	0.7
Inlet Air Barrel	0.3
Exhaust Barrel	0.3
Crankcase	0.02

A2.1.2 Use the values listed in Table A2.6 for all calculations.

A2.1.3 Use 6 min data to calculate the QI.

A2.1.4 Reset data that is greater than the high values listed in Table A2.6 from the Over and Under Range Values column to the high value for that particular parameter.

A2.1.5 Reset data that is less than the low values listed in Table A2.6 from the Over and Under Range Values column to the low value for that particular parameter.

A2.1.6 Round the QI values to the nearest 0.001.

A2.1.7 Report QI values on Form 3 of the test report.

NOTE A2.1—Refer to the DACA II Final Report for calculating the QI involving the loss of test data or bad quality test data.

A2.2 Formula to Calculate the Quality Index

A2.2.1

$$QI = 1 - \frac{1}{n} \sum \left(\frac{\alpha + \beta - 2X_i}{\beta - \alpha} \right)^2 \tag{A2.1}$$

where:

- X_i = recorded test measurement parameter,
- α = lower specification for that parameter,
- β = upper specification for that parameter, and
- n = total number of data points taken as determined from test length and procedural specified sampling rate.

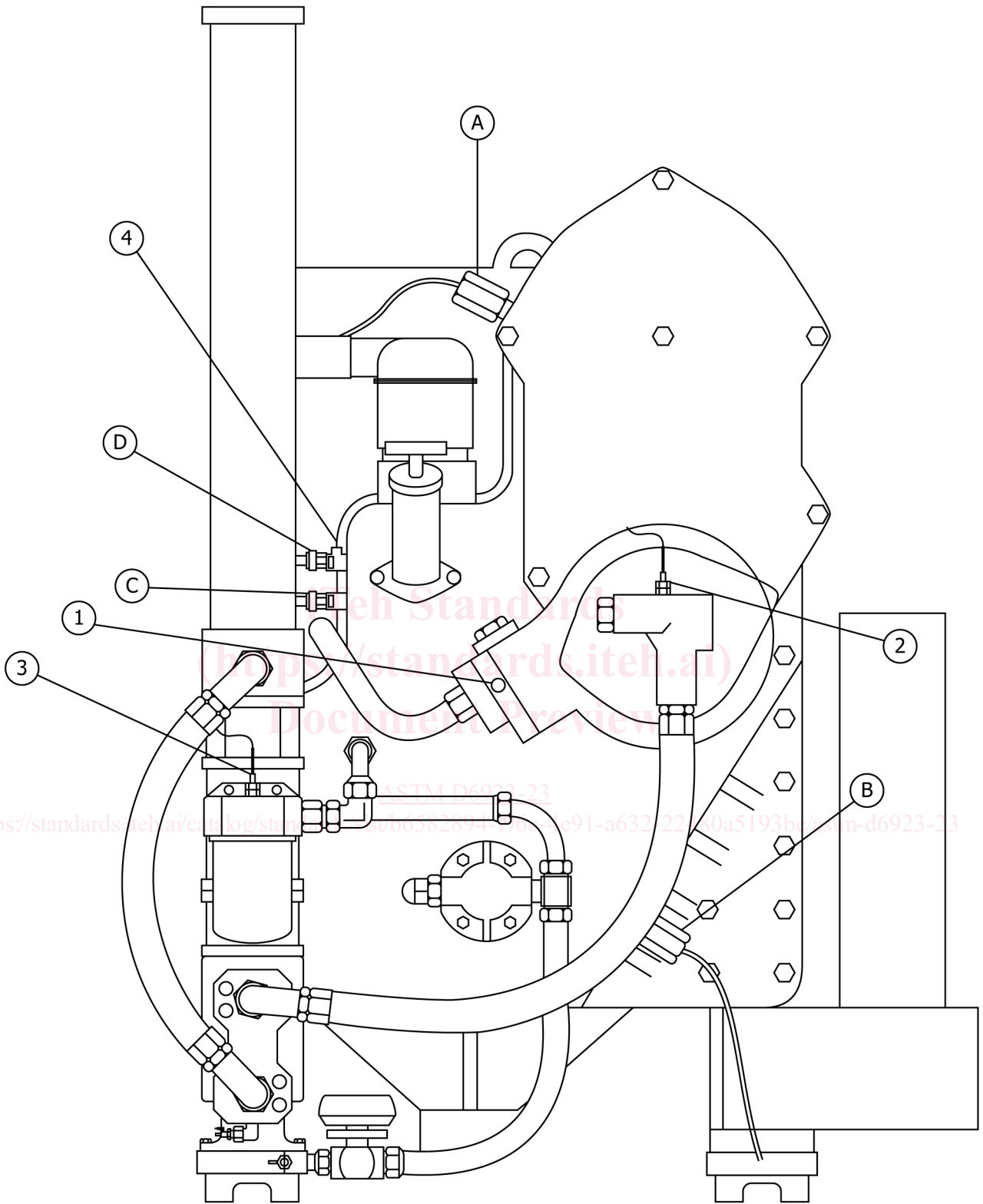

NOTE 1—See Table A2.1 for legend.

FIG. A2.1 Instrument Locations—Engine Front View