



Designation: D711 – 23

Standard Test Method for No-Pick-Up Time of Pavement Markings¹

This standard is issued under the fixed designation D711; the number immediately following the designation indicates the year of original adoption or, in the case of revision, the year of last revision. A number in parentheses indicates the year of last reapproval. A superscript epsilon (ϵ) indicates an editorial change since the last revision or reapproval.

This standard has been approved for use by agencies of the U.S. Department of Defense.

1. Scope

1.1 This test method covers a laboratory procedure for determining the no-pick-up time of pavement markings. The method uses a wheel consisting of a metal cylinder with rubber O-rings. The wheel is rolled down a ramp over a freshly applied pavement marking film repeatedly until there is no transfer of the marking material to the rubber rings. The elapsed time from pavement marking film application to point of no marking material transfer is the no-pick-up time. Key variables to be controlled during testing are wet film thickness, temperature, humidity, air flow, and use of retroreflective optics. This standard provides three options for the testing of the no-pick-up time for pavement markings. The first option, Method A, specifies controls for temperature, humidity, and air flow during testing; a second option, Method B, specifies controls for temperature and humidity during testing, and a third option, Method C, provides guidance for performing this with a drop on application of retroreflective optics such as glass beads. Waterborne and Solvent Borne pavement markings are typically tested using Procedure A or Procedure B, without the application of drop on retroreflective optics. Pavement markings that are two component 100 % solids are typically tested using Method C.

1.2 The values stated in SI units are to be regarded as the standard. The values given in parentheses are for information only.

1.3 *This standard does not purport to address all of the safety concerns, if any, associated with its use. It is the responsibility of the user of this standard to establish appropriate safety, health, and environmental practices and determine the applicability of regulatory limitations prior to use.*

1.4 *This international standard was developed in accordance with internationally recognized principles on standardization established in the Decision on Principles for the Development of International Standards, Guides and Recom-*

mendations issued by the World Trade Organization Technical Barriers to Trade (TBT) Committee.

2. Referenced Documents

2.1 *ASTM Standards:*²

- D823 Practices for Producing Films of Uniform Thickness of Paint, Coatings and Related Products on Test Panels
- D1212 Test Methods for Measurement of Wet Film Thickness of Organic Coatings
- D1414 Test Methods for Rubber O-Rings
- D2000 Classification System for Rubber Products in Automotive Applications
- D4414 Practice for Measurement of Wet Film Thickness by Notch Gages
- D5741 Practice for Characterizing Surface Wind Using a Wind Vane and Rotating Anemometer
- D8367 Practice for Making a Laboratory Pavement Marking Sample Using a Pavement Marking and Drop-on Particles

3. Significance and Use

3.1 This test method serves as a laboratory control test. Types of pavement markings that can be tested with this method are waterborne traffic paint, solvent borne traffic paint, and some two component 100 % solids liquid pavement markings, such as epoxy and modified epoxy pavement markings. If wet film thickness, temperature, and humidity are controlled within the tolerances specified herein, this method can be useful for relative testing of pavement markings and potentially for qualification of pavement markings for field application in approved specifications. For improved repeatability and meaningful comparison of pavement markings samples being tested, consistent air flow over the pavement marking films during testing is important. The buyer and seller should agree upon the air flow conditions, whether it be static or carefully regulated air flow (see 4.6.1 and 4.6.2). Because of the many variables operative in the field application of pavement markings (for example, wet film thickness, air temperature, humidity, wind speed, pavement type (asphalt or

¹ This test method is under the jurisdiction of ASTM Committee D01 on Paint and Related Coatings, Materials, and Applications and is the direct responsibility of Subcommittee D01.44 on Traffic Coatings.

Current edition approved June 1, 2023. Published July 2023. Originally approved in 1943. Last previous edition approved in 2020 as D711 – 20. DOI: 10.1520/D0711-23.

² For referenced ASTM standards, visit the ASTM website, www.astm.org, or contact ASTM Customer Service at service@astm.org. For *Annual Book of ASTM Standards* volume information, refer to the standard's Document Summary page on the ASTM website.

concrete), film profile over pavement, pavement temperature, pavement porosity, pavement moisture content, and the presence or absence of direct sunlight during striping), a direct correlation between the results of this test and field applications is difficult to obtain. However, relative field performance can be predicted using this method if the testing protocol is adhered to. For testing of two component 100 % solids liquid pavement markings an application of drop on retroreflective optics are typically applied at a specified rate to the markings prior to testing. For these types of pavement markings the regulation of air flow is not necessary due to the drying mechanics of the product.

4. Apparatus

4.1 The apparatus³ as shown in Fig. 1 shall consist of a steel

³ The sole source of supply of the apparatus known to the committee at this time that meets the requirements is available from Paul N. Gardner Co., Inc., 316 NE 1st St., Pompano Beach, FL 33060. If you are aware of alternative suppliers, please provide this information to ASTM International Headquarters. Your comments will receive careful consideration at a meeting of the responsible technical committee,¹ which you may attend.

cylinder of the shape and dimensions as indicated, fitted with two replaceable O-rings and a ramp of shape and dimensions as shown.

4.2 The detailed dimensional requirements of the steel cylinder are given in Fig. 1. The total weight of the assembly complete with O-rings shall be 5386 g ± 28 g (11 lb 14 oz ± 1 oz).

4.3 The detailed dimensional requirements of the ramp are shown in Fig. 1 and a picture of the apparatus with pavement marking film being tested is shown in Fig. 2.

4.4 The replaceable O-rings shall be made of synthetic rubber or rubber-like material meeting the requirements of HK 715 of Classification D2000. Standards for O-rings and rubber products are also found in Test Methods D1414 and Classification D2000.

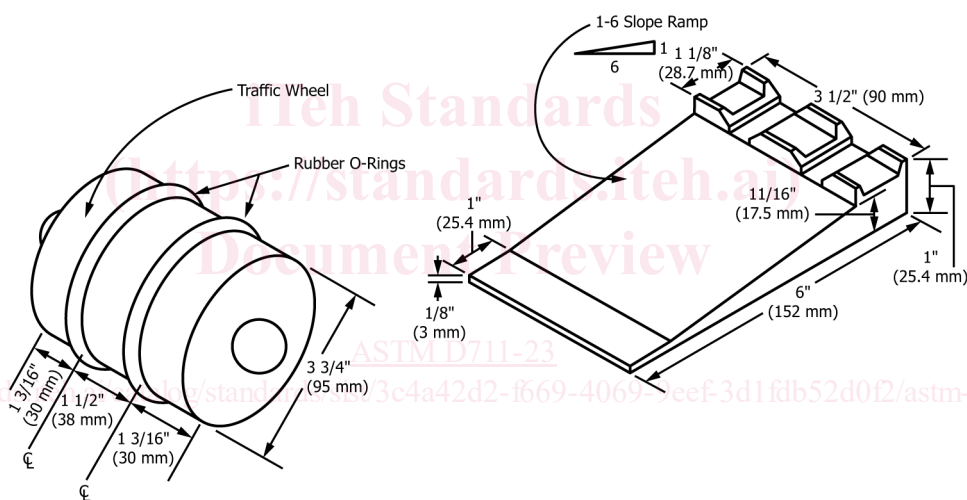
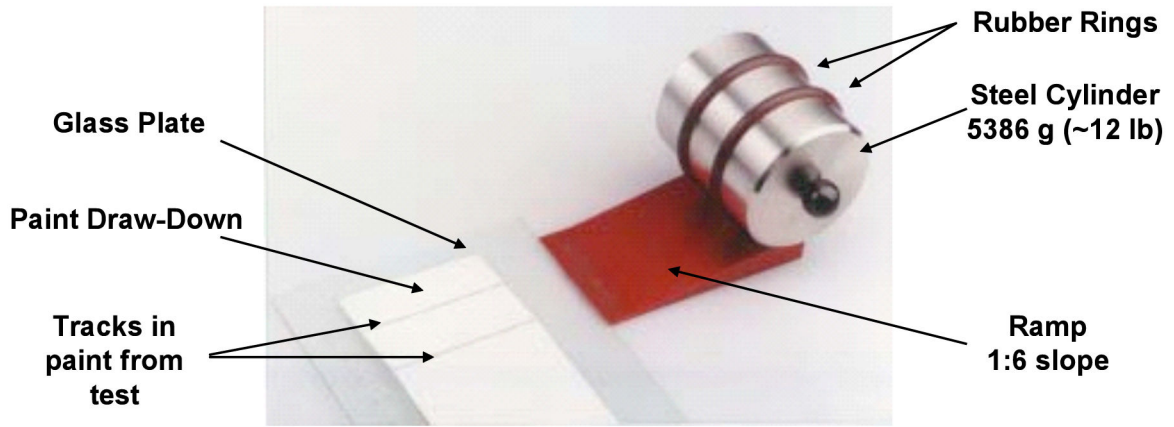

FIG. 1 Pavement Marking Drying Time Wheel and Ramp—Dual Model



Each pass of wheel over the pavement marking should be at least 25 mm (1 in.) from each end of the pavement marking film.

FIG. 2 Picture of Apparatus and Pavement Marking Film Being Tested

4.5 The dimensional requirements of the O-ring are as follows:

Outside diameter	104 mm (4 $\frac{1}{8}$ in.)
Inside diameter	85 mm (3 $\frac{3}{8}$ in.)
Cross section	9.5 mm ($\frac{3}{8}$ in.)

4.6 This test method is typically conducted in a laboratory or QC facility. For waterborne and solvent borne traffic, values and tolerances are specified for wet film thickness, temperature, relative humidity, and air flow. Each of these factors can have a strong effect on no-pick-up time if not carefully controlled. Other things being equal, no-pick-up times are reduced (faster) with a thinner film, higher temperature, lower relative humidity, increased air flow, and the addition of surface applied retroreflective optics. Air flow has a strong effect on no-pick-up time (See Fig. 3) for waterborne and solvent borne traffic paints, resulting in reduced no-pick-up times with higher flow rates. Even minor variations in air movement at different locations within the

same laboratory can affect no-pick-up time results when testing these types of pavement markings. For two component 100 % solids pavement markings, factors such as wet film thickness, ambient temperature, material temperature, and the type and quantity of retroreflective optics applied to the surface of the marking play a significant role in dry time. In addition, one needs to consider humidity when working with two component polyurea materials. Therefore, these factors should be specified and followed when performing this test for these two component 100 % solids system. The conditions and associated apparatus for controlling air flow are described in the following subsections.

4.6.1 When using Method A: Controlled Air flow, as outlined in 5.1, air flow shall be regulated during testing to establish controlled air flow over the applied pavement markings at a fixed wind speed. One possible apparatus to control wind speed is shown in Fig. 4. This setup includes a 51 cm

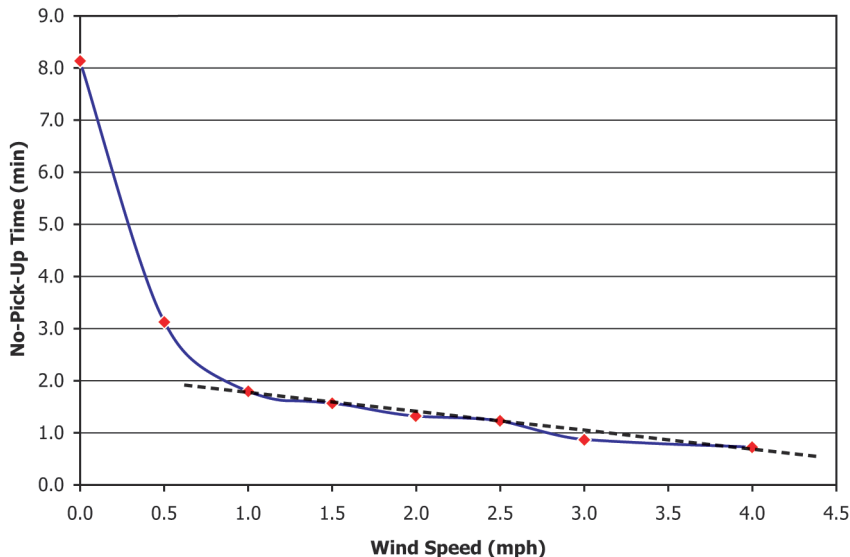

Testing was conducted on individual drawdowns of the waterborne traffic paint at 16 mil wet film thickness, 23 °C, and 52 % relative humidity with wind speed varied over the paint films. Wind speed was controlled by box fan, variable transformer to adjust fan speed, and precision air flow meter as shown in Fig. 4.

FIG. 3 Effect of Wind Speed on No-Pick-Up Time for a Fast-dry Traffic Paint

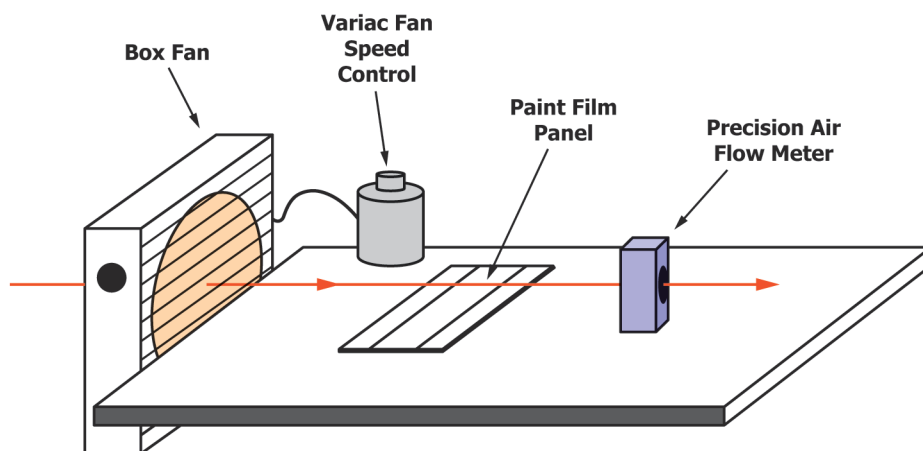

FIG. 4 Apparatus for Controlling Wind Speed Over a Pavement Marking Film During No-Pick-Up Time Testing

(20 in.) box fan, a variable transformer (voltage regulator) for fan speed control, and a precision anemometer for measurement and adjustment of the air flow. In a standard format, the glass plate for the pavement marking film drawdown is located 61 cm (24 in.) from the fan perpendicular to the air flow. A precision anemometer is located on the opposite side of the glass plate. The variable transformer is adjusted to obtain the desired wind speed over the glass plate. Once the correct wind speed is obtained, the pavement marking film is drawn down on the glass plate and no-pick-up testing is conducted. If this approach is used, a wind speed of 1.6 kph to 0.2 kph (1 mph to 0.1 mph) is recommended where the slope of dry time versus wind speed is lower and in the linear region (see Fig. 3).

4.6.2 To minimize the effects of air flow when using Method B: Static Air Flow as outlined in 5.2 or Method C Beaded Static Air Flow for 100 % Solids 2 Component Coatings as outlined in Section 5.3, a location for testing in the laboratory should be selected that is free of drafts with no perceptible air movement. An air flow meter (anemometer) may be helpful in detecting drafts. The use of an anemometer is detailed in Practice D5741. A condition of static air flow is considered to be detected air flow of with less than 0.2 kph (0.1 mph) in a 360° direction around the drawdown as measured by air flow meter (anemometer). If drafts are detected, air flow can be minimized by using an enclosure (open front with solid top, back, and sides) around the test apparatus with approximate dimensions 61 cm wide by 46 cm deep by 46 cm tall (24 in. by 18 in. by 18 in.). The enclosure can be made of plastic or other suitable material. If an air conditioning system is used to control room temperature and humidity, the system should be set to “On” rather than “Auto” to maintain constant air movement during testing. Note that test chambers with high air turnover may give much faster no-pick-up times.

4.7 Pavement marking film wet thickness is a critical factor and must be tightly controlled to obtain reliable and reproducible results. Procedures for producing uniform pavement marking films are found in Practices D823: Practice C, Motor Driven Blade Film Applicators, and Practice E, Handheld Blade Film Applicators. Be aware that the number (in mils, microns, or mm) printed on many types of film applicator “draw-down” bars is the clearance (gap), and that the wet film

thickness of the pavement marking applied using those applicators is often significantly less than the gap (typically 50 % to 70 % of the clearance for waterborne traffic paints). Some “Bird” applicators have markings that indicate the approximate wet film thickness expected, while some “bird type” applicators have markings indicating the gap. The applied pavement marking films should be checked for wet film thickness to ensure that they are $0.381 \text{ mm} \pm 0.0127 \text{ mm}$ (15 mils \pm 0.5 mils). Procedures for measurement of wet film thickness are found in Test Methods D1212 and Practice D4414. Appropriate notched or roller gauges may be used.

5. Procedure

5.1 Method A: Controlled Air Flow:

5.1.1 Condition the substrate material (glass plate), the pavement marking material to be tested, and the application device for a minimum of one hour at laboratory conditions at $23 \text{ }^\circ\text{C} \pm 2 \text{ }^\circ\text{C}$ ($73.5 \text{ }^\circ\text{F} \pm 3.5 \text{ }^\circ\text{F}$). Using a thermometer having a range from $20 \text{ }^\circ\text{C}$ to $70 \text{ }^\circ\text{C}$ and conforming to the requirements for Thermometer 49C, or an equivalent device meeting these same requirements, stir the pavement marking specimen and bring to $23 \text{ }^\circ\text{C} \pm 2 \text{ }^\circ\text{C}$ ($73.5 \text{ }^\circ\text{F} \pm 3.5 \text{ }^\circ\text{F}$) and maintain it to that temperature during the preparation of the test stripe.

5.1.2 Prepare a test stripe at least 75 mm (3 in.) in width of the pavement marking to be tested by a mechanical spreader, or other suitable means on a clean plate glass panel at a wet film thickness of $0.38 \text{ mm} \pm 0.01 \text{ mm}$ (15 mils \pm 0.5 mils). Use a plate glass panel approximately 100 mm by 200 mm by 3 mm (4 in. by 8 in. by $\frac{1}{8}$ in.). For guidance in preparing uniform applications at the prescribed wet film thickness see 4.7.

5.1.3 Record the time of application. Allow the panel to dry in a horizontal position under the laboratory conditions specified: $23 \text{ }^\circ\text{C} \pm 2 \text{ }^\circ\text{C}$ ($73.5 \text{ }^\circ\text{F} \pm 3.5 \text{ }^\circ\text{F}$), 50 % \pm 5 % relative humidity, and $1.6 \text{ kph} \pm 0.2 \text{ kph}$ (1 mph \pm 0.1 mph) of controlled air flow as outlined in 4.6.1.

5.1.4 Test the pavement marking without drop-on beads unless otherwise specified or agreed upon between the purchaser and the seller.

5.1.5 Butt the glass plate against the ramp. Position the wheel so that the rubber ring rolls an area of the film at least 2.54 cm (1 in.) from the edge (either end) of the test stripe. At

regular time intervals remove the wheel from its rest, hold outside and against the rest as a starting point, then release the weighted wheel to roll down the inclined ramp and over the paint film with each roll of the wheel over a new wheel path. Clean the wheel after each pass over the film. This can be done with a clean rag. At the end of the test the wheel can be cleaned with a rag saturated with acetone. It is best to set aside the wheel after washing until all the solvent has evaporated before using in subsequent testing.

5.1.6 Note the end point for no-pick-up time when no pavement marking material adheres to the rubber rings of the test wheel when it is rolled over the pavement marking film. A shadow stain, usually consisting of dry, translucent pigment transfer is not considered to be pavement marking material transfer and therefore not considered to be a failure. As the end point is approached, roll the weighted wheel over the pavement marking film every 30 s.

5.1.7 Even when all four factors of wet film thickness, temperature, humidity, and air flow are controlled, their additive effect within the specified tolerances can still result in some no-pick-up time variability. A recommended approach for resolving this issue is to establish a control pavement marking that is tested either just before or just after each new pavement marking being tested. The control pavement marking should be mutually agreed upon by buyer and seller and used for all testing conducted over a specified period of time, for example, six months. Besides the absolute no-pick-up time values reported for the pavement marking and control pavement marking, results for each new pavement marking can be expressed as a “% of control” as is done in some other coatings test procedures. A % of control higher than 100 % would be a longer no-pick-up time while less than 100 % would be a shorter no-pick-up time.

5.2 Method B: Static Air Flow:

5.2.1 Condition the substrate material, the pavement marking material to be tested, and the application device for a minimum of one hour at laboratory conditions at $23\text{ }^{\circ}\text{C} \pm 2\text{ }^{\circ}\text{C}$ ($73.5\text{ }^{\circ}\text{F} \pm 3.5\text{ }^{\circ}\text{F}$). Using a thermometer having a range from $20\text{ }^{\circ}\text{C}$ to $70\text{ }^{\circ}\text{C}$ and conforming to the requirements for Thermometer 49C, or an equivalent device meeting these same requirements, stir the pavement marking specimen and bring to $23\text{ }^{\circ}\text{C} \pm 2\text{ }^{\circ}\text{C}$ ($73.5\text{ }^{\circ}\text{F} \pm 3.5\text{ }^{\circ}\text{F}$) and maintain it to that temperature during the preparation of the test stripe.

5.2.2 Prepare a test stripe at least 75 mm (3 in.) in width of the pavement marking to be tested by a mechanical spreader, or other suitable means on a clean plate glass panel at a wet film thickness of $0.38\text{ mm} \pm 0.01\text{ mm}$ (15 mils \pm 0.5 mils). Use a plate glass panel approximately 100 mm by 200 mm by 3 mm (4 in. by 8 in. by $\frac{1}{8}$ in.). For guidance in preparing uniform applications at the prescribed wet film thickness see 4.7.

5.2.3 Record the time of application. Allow the panel to dry in a horizontal position under the laboratory conditions specified: $23\text{ }^{\circ}\text{C} \pm 2\text{ }^{\circ}\text{C}$ ($73.5\text{ }^{\circ}\text{F} \pm 3.5\text{ }^{\circ}\text{F}$), $50\text{ } \% \pm 5\text{ } \%$ relative humidity and static air flow conditions as outlined in 4.6.2.

5.2.4 Test the pavement marking without drop-on beads unless otherwise specified or agreed upon between the purchaser and the seller.

5.2.5 Butt the glass plate against the ramp. Position the wheel so that the rubber ring rolls an area of the film at least 2.54 cm (1 in.) from the edge (either end) of the test stripe. At regular time intervals remove the wheel from its rest, hold outside and against the rest as a starting point, then release the weighted wheel to roll down the inclined ramp and over the pavement marking film with each roll of the wheel over a new wheel path. Clean the wheel after each pass over the film. This can be done with a clean rag. At the end of the test the wheel can be cleaned with a rag saturated with acetone. It is best to set aside the wheel after washing until all the solvent has evaporated before using in subsequent testing.

5.2.6 Note the end point for no-pick-up time when no pavement marking material adheres to the rubber rings of the test wheel when it is rolled over the pavement marking film. A shadow stain, usually consisting of dry, translucent pigment transfer is not considered to be pavement marking material transfer and therefore not considered to be a failure. As the end point is approached, roll the weighted wheel over the pavement marking film every 30 s.

5.2.7 Even when all four factors of wet film thickness, temperature, humidity, and air flow are controlled, their additive effect within the specified tolerances can still result in some no-pick-up time variability. A recommended approach for resolving this issue is to establish a control pavement marking that is tested either just before or just after each new pavement marking being tested. The control pavement marking should be mutually agreed upon by buyer and seller and used for all testing conducted over a specified period of time, for example, six months. Besides the absolute no-pick-up time values reported for the test pavement marking and control pavement marking, results for each new pavement marking can be expressed as a “% of control” as is done in some other coatings test procedures. A % of control higher than 100 % would be a longer no-pickup time while less than 100 % would be a shorter no-pick-up time.

5.3 Method C: Beaded Static Air Flow for 100 % Solids 2 Component Coatings:

5.3.1 This procedure is intended for use with two component 100 % solids pavement markings including epoxy, modified epoxy, polyurea, and methylmethacrylate (MMA). The application can be made with or without an application of surface applied (drop on) retroreflective optics. If the use of surface applied retroreflective optics are required, the specified type and rate should be agreed upon by the user and seller. Typically, uncoated AASHTO M247 Type 1 glass beads are used with this procedure when drop on retroreflective optics are required by the user. Some two-component pavement markings with very quick track free times (4 min to 5 min) such as polyurea and some acrylated epoxy pavement markings may not lend themselves to this test. For the test to be relevant there must be adequate time to prepare the test sample and perform the test before the material reaches a track free state. For fast cure systems it is best to mix using a static adhesive dispensing gun (see 5.3.2.1).

5.3.2 Mixing of the two component materials into a properly proportioned, homogenous blend is a critical step in obtaining accurate results when using this method. Proper