



Designation: D6117 – 23

Standard Test Methods for Mechanical Fasteners in Plastic Lumber and Shapes¹

This standard is issued under the fixed designation D6117; the number immediately following the designation indicates the year of original adoption or, in the case of revision, the year of last revision. A number in parentheses indicates the year of last reapproval. A superscript epsilon (ϵ) indicates an editorial change since the last revision or reapproval.

INTRODUCTION

The use of plastic lumber and shapes often involves the use of mechanical fasteners, such as nails, screws, bolts, lag screws, and connectors. Data on the strength and performance of such fasteners are frequently needed for design and for comparative purposes. Presented herewith are methods of conducting tests for nail, staple and screw withdrawal resistance and lateral load transmission by nail, staple, screw, and bolt. The use of standard methods for these tests is recommended as a means of obtaining comparable data and of eliminating variables in test results because of variation in testing methods.

1. Scope*

1.1 These test methods cover the evaluation of fastener use with “as manufactured” plastic lumber and shapes through the use of two different testing procedures.

1.2 The test methods appear in the following order:

Test Method	Sections
A—Nail, Staple, or Screw Withdrawal Test	4 to 13
B—Nail, Staple, or Screw Lateral Resistance Test	14 to 22

1.3 Plastic lumber and plastic shapes are currently made predominately from recycled plastics. However, these test methods would also be applicable to similar manufactured plastic products made from virgin resins where the product is non-homogeneous in the cross-section.

1.4 The values stated in inch-pound units are to be regarded as standard. The SI units given in parentheses are for information only.

1.5 *This standard does not purport to address all of the safety concerns, if any, associated with its use. It is the responsibility of the user of this standard to establish appropriate safety, health, and environmental practices and determine the applicability of regulatory limitations prior to use.*

NOTE 1—There is no known ISO equivalent to this standard.

1.6 *This international standard was developed in accordance with internationally recognized principles on standardization established in the Decision on Principles for the Development of International Standards, Guides and Recom-*

¹ These test methods are under the jurisdiction of ASTM Committee D20 on Plastics and are the direct responsibility of Subcommittee D20.20 on Plastic Lumber.

Current edition approved July 1, 2023. Published July 2023. Originally approved in 1997. Last previous edition approved in 2018 as D6117 - 18. DOI: 10.1520/D6117-23.

mendations issued by the World Trade Organization Technical Barriers to Trade (TBT) Committee.

2. Referenced Documents

2.1 ASTM Standards:²

D883 Terminology Relating to Plastics

D1761 Test Methods for Mechanical Fasteners in Wood and Wood-Based Materials

D6111 Test Method for Bulk Density And Specific Gravity of Plastic Lumber and Shapes by Displacement

D6341 Test Method for Determination of the Linear Coefficient of Thermal Expansion of Plastic Lumber and Plastic Lumber Shapes Between –30 and 140°F (–34.4 and 60°C)

E4 Practices for Force Calibration and Verification of Testing Machines

2.2 ANSI Standards:³

B18.6.1 American National Standard for Slotted and Recessed Head Wood Screws

3. Terminology

3.1 Definitions:

3.1.1 For definitions of terms relating to plastics used in this test method, refer to Terminology D883.

3.2 Definitions of Terms Specific to This Standard:

3.2.1 *plastic shape, n*—a manufactured product made primarily from plastic materials (filled or unfilled), which is not necessarily rectangular in cross section.

² For referenced ASTM standards, visit the ASTM website, www.astm.org, or contact ASTM Customer Service at service@astm.org. For *Annual Book of ASTM Standards* volume information, refer to the standard’s Document Summary page on the ASTM website.

³ Available from American National Standards Institute (ANSI), 25 W. 43rd St., 4th Floor, New York, NY 10036, http://www.ansi.org.

*A Summary of Changes section appears at the end of this standard

TEST METHOD A—NAIL, STAPLE, OR SCREW WITHDRAWAL TEST

4. Scope

4.1 This test method provides a basic procedure for evaluating the resistance of plastic lumber and shapes materials to direct withdrawal of nails, staples, and screws. Spikes are included as nails in this test method.

4.2 This test method also provides a basis for determining comparable performance of different types and sizes of nails, staples, and screws in direct withdrawal from plastic lumber and shapes.

5. Summary of Test Method

5.1 Specimens consist of “as manufactured” plastic lumber and shapes, with nails, staples, or screws driven at right angles to one or more faces. The fasteners are withdrawn at a uniform rate of speed by means of a testing machine, and the maximum load is recorded. Supplementary physical properties of the plastic lumber and shapes are also determined.

6. Significance and Use

6.1 The resistance of plastic lumber and shapes to direct withdrawal of nails, staples, or screws is a measure of its ability to hold or be held to an adjoining object by means of such fasteners. Factors that affect this withdrawal resistance include the physical and mechanical properties of the plastic lumber and shapes; the size, shape, and surface condition of the fasteners; the speed of withdrawal; physical changes to plastic lumber and shapes or fasteners between time of driving and time of withdrawal; orientation of fiber axis; the occurrence and nature of prebored lead holes; and the temperatures during insertion and withdrawal. These factors will be as circumstances dictate, and representative of the normal manufacturing process.

6.2 By using a standard size and type of nail, staple, or screw, withdrawal resistance of plastic lumber and shapes can be determined. Throughout the method this is referred to as the basic withdrawal test. Similarly, comparative performances of different sizes or types of nail, staple, or screw can be determined by using a standard procedure with a particular plastic lumber and shape, which eliminates the plastic lumber and shapes product as a variable. Since differences in test methods can have considerable influence on results, it is important that a standard procedure be specified and adhered to, if test values are to be related to other test results.

7. Apparatus

7.1 *Testing Machine*—Any suitable testing machine that is capable of operation at a constant rate of motion of the movable head and has an accuracy of $\pm 1\%$ when calibrated in accordance with Practices E4.

7.2 *Grips*—A gripping device shaped to fit the base of the fastener head and of such a design as to allow accurate clamping assembly that will hold the specimen to one platen of the machine is also required. A suitable test mechanism for screw withdrawal is illustrated in Fig. 1.

8. Test Nails, Staples, or Screws

8.1 Nails:

8.1.1 Nails used for basic withdrawal tests shall be diamond-point round-wire, low-carbon-steel nails nominally 0.148 in. (3.76 mm) in diameter and 3 in. (76 mm) in length (See Note 2). Use each nail only once.

NOTE 2—A 10d galvanized common steel wire nail meets this requirement.

8.1.2 For determining holding ability of different sizes or types of nails in plastic lumber and shapes, the respective sizes and types of nail will be as circumstances dictate. These nails shall be representative of the normal manufacturing process, and special cleaning of the shank shall normally not be undertaken.

8.2 Staples:

8.2.1 Staples used for basic leg withdrawal resistance shall be nominally 2.0-in. (51-mm) long, $\frac{7}{16}$ -in. (11-mm) crown, 15 gage (0.072-in. (1.83-mm)) galvanized steel staples. Use each staple only once.

8.2.2 For determining holding ability of different types or sizes of staples in plastic lumber and shapes, the respective staples shall be representative of the normal manufacturing process, and special cleaning of the legs shall not normally be undertaken.

8.3 Screws:

8.3.1 Screws used for basic withdrawal tests shall be nominally 1-in. (25-mm) No. 10—gage flathead low-carbon-steel wood screws as described in ANSI B18.6.1. Use each screw only once.

8.3.2 For determining holding ability of different sizes and types of screws in plastic lumber and shapes, the respective size and types of screw will be as circumstances dictate. These screws shall be representative of the normal manufacturing process.

9. Sampling

9.1 Sampling needs to provide for selection of representative test materials on an objective and unbiased basis, covering an appropriate range in density and properties as circumstances suggest.

9.2 The tests need to be sufficiently extensive to provide reliable results. Where analysis by statistical procedures is contemplated, experience and sometimes advance estimates can be used to establish the scope of testing and type of sampling needed to achieve the expected reliability.

NOTE 3—The precision required, and thus the manner of sampling and number of tests, will depend upon specific objectives. No specific criteria therefore can be established. General experience indicates that the coefficient of variation from tests of fasteners ranges from about 15 to 30%. When such is the case, precision of 5 to 10%, with 95% confidence (an often-accepted general measure of reliability for testing of wood products) cannot be achieved without making a rather large number of tests. The present recommendation is to make at least ten replications for each variable as a minimum requirement.

10. Test Specimen

10.1 Nail and Staple Withdrawal

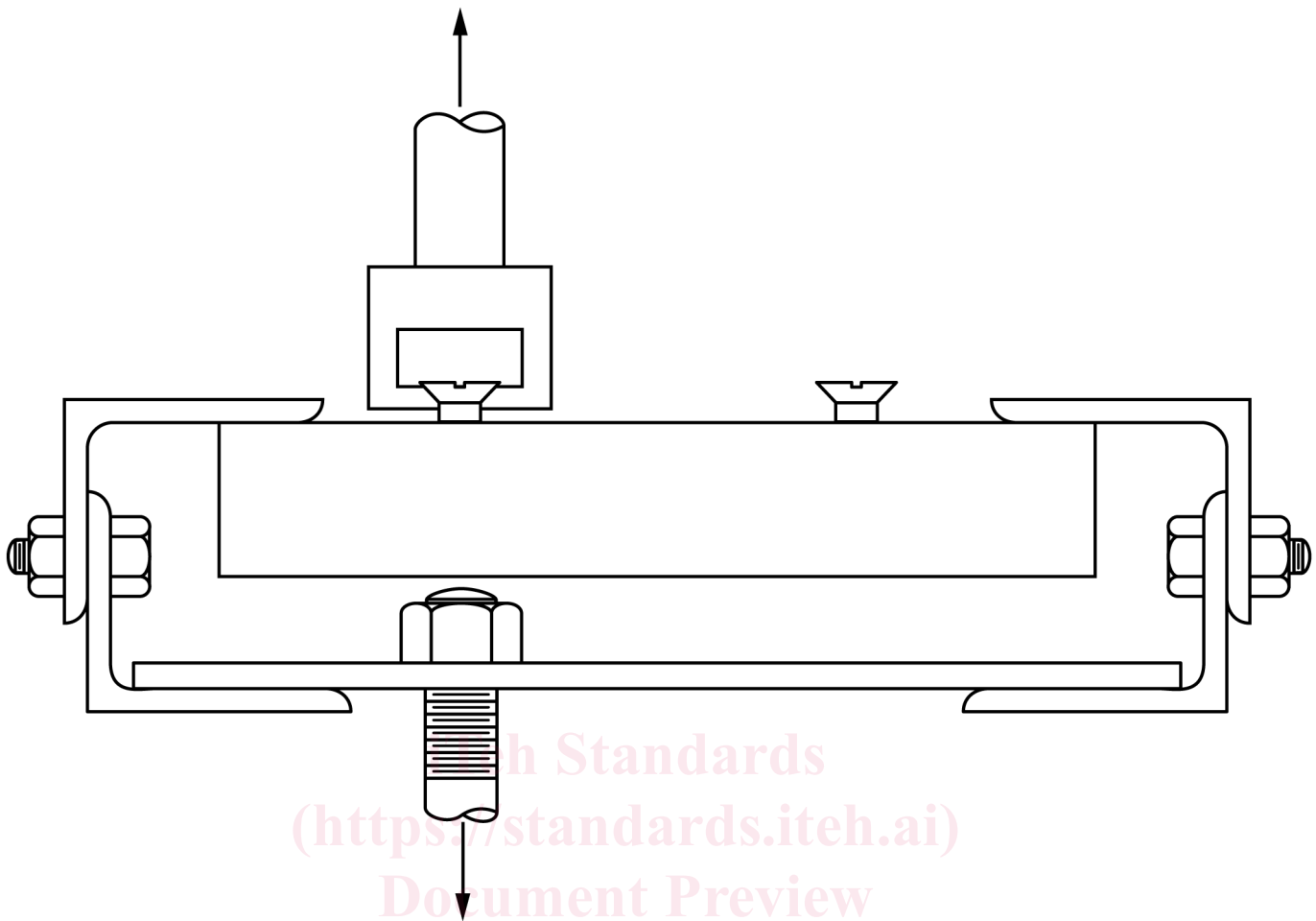

FIG. 1 Diagram of Assembly for Screw Withdrawal Test

ASTM D6117-23

10.1.1 For basic withdrawal tests from plastic lumber, cut the test specimens to length from the “as manufactured” profile. Drive nails of the type outlined in 8.1.1 and staples of the type outlined in 8.2.1 at right angles to the face of the specimen to a minimum total penetration of 1¼ in. (32 mm). With the specimen oriented in a flatwise (plank) position, drive two fasteners into the top face (width), two into the side face (height), and one into each end. End and edge distances shall be sufficient to avoid splitting. In general, edge distances need to be not be less than 1½ in. (38 mm) and two fasteners shall not be driven in line with each other or less than 2 in. (50 mm) apart on the top and side faces. Drive nails manually with a hammer. Insert staples with an appropriate tool, as nearly as possible perpendicular to the specimen surface, with the staple crown at a 45° (±10°) angle to the axial dimension of the specimen.

10.1.2 For basic withdrawal tests from plastic shapes, the test specimen shall be a single thickness of the “as manufactured” product. Drive nails of the type outlined in 8.1.1 through the specimen at right angles to the face, permitting at least ½ in. (13 mm) of the shank portion to remain above the surface. Drive nails manually by means of a hammer. Insert staples with an appropriate tool as in 10.1.1, with the staple crown oriented at a 45° (±10°) angle to the axial dimension of the specimen.

10.1.3 *Fasteners Other Than Those Described in 8.1.1 or 8.2.1*—For determining the withdrawal resistance of particular sizes and shapes of nails or staples in plastic lumber and shapes, the specimen shall be of convenient size to accommodate the quantity of fasteners to be tested in each specimen, without exceeding the edge and end distances and spacing necessary to avoid splitting. In plastic lumber and shapes, drive fasteners to 70 % of their length; in plastic lumber and shapes less than 1-in. (25-mm) thick, drive them completely through the thickness with at least ½ in. (13 mm) of the shank portion remaining above the surface. Drive the fasteners by the method intended to be used in practice, that is, either manually with a hammer, or with an applicator or appropriate tool if this is the normal method.

10.1.3.1 If the potential exists for the withdrawal resistance to be influenced by the material in which the fastener is to be driven, drive the fastener through the fastened member (cleat) into the base fastening member.

10.2 *Screw Withdrawal:*

10.2.1 For basic withdrawal tests from plastic lumber, cut the test specimens to length from the “as manufactured” profile. With the specimen oriented in a flatwise (plank) position, thread two screws of the type outlined in 8.3.1 into

lead holes at right angles to the top face (width), two into the side face (height), and one into each end, each to a total penetration equal to the length of the threaded portion. End and edge distance shall be sufficient to avoid splitting, which in general will be at least $\frac{3}{4}$ in. (19 mm) from the edge and $1\frac{1}{2}$ in. (38 mm) from the end, and spacing will be at least $2\frac{1}{2}$ in. (63 mm) apart on the top and side faces.

10.2.2 For basic withdrawal tests from plastic shapes, the test specimen shall be a single thickness of the “as manufactured” product. The depth of the specimen shall be at least equal to the length of the screw. Thread screws of the type outlined in 8.3.1 into the specimen a distance of $\frac{1}{16}$ in. (17 mm) at midwidth, at least 2 in. (50 mm) from the end of the specimen. The size of lead hole shall be 70 % of the root diameter of the screw and it shall extend $\frac{1}{2}$ in. (13 mm) into the face of the specimen.

10.2.3 For determining the withdrawal resistance of particular sizes and types of screws in plastic lumber and shapes, the specimen shall be of convenient size to accommodate the quantity of screws to be tested in each specimen, without exceeding the edge and end distances and spacing necessary to avoid splitting. Thread screws into the specimen for the length of the threaded portion of the shank or two-thirds of the shank length if it is fully-threaded. The size of lead hole, if one is to be drilled, shall be 70 % of the root diameter of the screw for a distance of one half of the screw length.

10.2.3.1 If the potential exists for the withdrawal resistance to be influenced by the material through which the screw is to be threaded, thread the screw through the fastened member (cleat) into the base fastening member.

11. Conditioning

11.1 Nail, staple, and screw withdrawal tests are conducted on the final “as manufactured” end product. Store the nail, staple, screw, and the plastic lumber and shapes in a room having a controlled temperature of $73.4 \pm 3.6^\circ\text{F}$ ($23 \pm 2^\circ\text{C}$) and a controlled relative humidity of $50 \pm 5\%$ for a period of 48 h. It is acceptable to alter conditioning as circumstances dictate to be representative of the normal manufacturing process.

12. Procedure

12.1 *General*—Except for special circumstances requiring immediate withdrawal (See Note 4), withdraw fasteners after a minimum period of 24 h and no longer than 48 h.

NOTE 4—Due to localized heating of the specimen, immediate withdrawal will result in values lower than would be encountered in service.

12.2 Basic Loading Method:

12.2.1 Where the specimen consists of the single piece into which the fasteners were inserted, withdraw the fasteners by means of a tensile force applied at a uniform rate of withdrawal. Attach the specimen to one platen of the testing machine. Attach the fastener head to a suitably-designed grip that is fastened to the other platen through a universal joint. Apply the load by separation of the platens of the testing machine at a uniform rate of withdrawal. Read the maximum load required to withdraw the fastener from the plastic lumber and shape to three significant figures. Disregard test values

resulting from any failure of the fastener in the evaluation of the performance of the plastic lumber and shapes materials but report them; consider such failures in the evaluation of the performance of different types and sizes of fasteners. In such cases, an additional replication is desirable.

12.2.2 Where the specimen consists of a base piece to which one or more cleats have been fastened thereto with a fastener, two test procedures are possible. The fastened member (cleat) can be grasped and pushed or pulled away for the base fastening member in the axial direction of the fastener, whereby the fastener head exerts a force on the fastened member. Under this procedure, if the fastened member exerts less resistance to the passage of the fastener head than the fastening member exerts on fastener withdrawal, head pull-through can occur. In such a case, the pull-through resistance of the fastened material will be indicated. The fastened member can be split off and the fastener withdrawn as in 12.2.1.

12.3 *Special Loading Methods*—It will some times be necessary to determine the resistance to withdrawal as a result of an impact force or by repetitive loads. In the case of the former, this can be accomplished with standard apparatus such as the U.S. FPL toughness testing machine suitably modified to hold and grip the withdrawal specimen. It is possible that the U.S. FPL test will require the use of a cycling or pulsating loading head. The resulting data are based on the displacement angle of the pendulum and the forces resulting from the setting of the repetitive loading mechanism, respectively, which are required to withdraw the fastener from the plastic lumber or shape. Disregard test values resulting from any failure of the fastener in the evaluation of the performance of plastic lumber and shapes materials, but report if desired; consider such failures in the evaluation of the performance of different types and sizes of fasteners. In such cases, an additional replication is desirable.

12.4 Speed of Testing: 93e0f8be/astm-d6117-23

12.4.1 Conduct the test at a uniform rate of platen separation of 0.10 in. (2.5 mm)/min $\pm 25\%$ (see Note 5).

12.4.2 For special loading methods, it is possible that special rates of withdrawal will be required. Record the rate used and the reasons for choosing it in the report.

NOTE 5—The rate of platen separation shall mean the free-running, or no-load, crosshead speed for testing machines of the mechanical drive type, and the loaded crosshead speed for testing machines of the hydraulic loading type.

12.5 *Supplementary Tests*—If information on the actual withdrawal during load application is desired or has the potential to influence the interpretation of the withdrawal resistance of a given fastener, measure and record such withdrawal, in inches, at given withdrawal loads or at the ultimate withdrawal resistance, in pounds, to three significant figures. Under given conditions, it will some times be expeditious to obtain an automatic plot of withdrawal load versus withdrawal distance in order to determine the stiffness of the joint and the work involved up to a given point of withdrawal of the fastener under construction.

12.6 *Minor Tests*—Determine the specific gravity (bulk density) of the plastic lumber or shape in accordance with Test Method D6111.

13. Report

13.1 Report the following information:

13.1.1 Complete identification of the material tested, including type, source, manufacturer's code number, form, principle dimensions, and previous history;

13.1.2 Laboratory name;

13.1.3 Date of test;

13.1.4 Number of tests;

13.1.5 A complete description of the test method and loading procedure used;

13.1.6 Failure loads for individual fasteners, average test values, statistical evaluation of the test data if justified;

13.1.7 A description of the specimen, including the dimensions of the plastic lumber or shape components, type and size of fastener, end and edge distances, and spacing;

13.1.8 Average specific gravity (bulk density) of the plastic lumber and shapes as determined by Test Method **D6111**;

13.1.9 Details of temperature and time history of insertion, as well as temperature and time history of withdrawal;

13.1.10 Details of any deviations from the prescribed or recommended methods as outlined in the standard; and

13.1.11 Details of any factors not included above that might have a bearing on results.

TEST METHOD B—NAIL, STAPLE, OR SCREW LATERAL RESISTANCE TEST

14. Scope

14.1 This test method covers the determination of the resistance to lateral movement offered by a single nail, staple, or screw in plastic lumber and shapes.

14.2 Where required for specific purposes, the general test method can be used for evaluating the lateral resistance of sizes of nails, staples, and screws other than those specified, and joints employing two or more fasteners. It is recommended that when such tests are made, the specified procedure be followed as closely as possible and all deviations be completely described.

15. Summary of Test Method

15.1 Specimens consist of “as manufactured” plastic lumber and shapes, with nails, staples, or screws driven at right angles to the specimen face. Fasteners are driven through a fastened member (cleat) into an overlapping base fastening specimen member. The cleat and the base fastening member are then separated from each other, at a uniform rate, using a tensile force perpendicular to the fastener. The maximum load is recorded. Supplementary physical properties of the plastic lumber and shapes are also determined.

16. Significance and Use

16.1 The resistance of plastic lumber and shapes to a lateral force applied to embedded nails, staples, or screws is a measure of its ability to hold or be held to an adjoining object by means of such fasteners.

16.2 By using a standard size and type of nail, staple, or screw, the lateral resistance of plastic lumber and shapes can be

determined. Similarly, comparative performances of different sizes or types of nails, staples, or screws can be determined by using a standard procedure with a particular plastic lumber and shape, that eliminates the plastic lumber and shapes as a variable. Since differences in test methods can have considerable influence on results, it is important that a standard procedure be specified and adhered to, if test values are to be related to other test results.

16.3 Where both the cleat and the fastening member are plastic lumber, this method provides a suitable procedure for evaluating the strength and rigidity of joints that would be subjected to lateral loadings as per this test method.

17. Test Nails, Staples, or Screws

17.1 *Nails:*

17.1.1 Nails used shall be diamond-point round-wire, low-carbon-steel nails nominally 0.148 in. (3.76 mm) in diameter and 3 in. (76 mm) in length (see **Note 6**). Use each nail only once. Record the actual size and details of the nails selected, including data on the properties of the metal.

NOTE 6—A 10d galvanized common wire nail meets this requirement.

17.1.2 For determining holding ability of different sizes or types of nails in plastic lumber and shapes, the respective sizes and types of nail will be as circumstances dictate. These nails shall be representative of the normal manufacturing process, and special cleaning of the shank shall normally not be undertaken.

17.2 *Staples:*

17.2.1 Staples used shall be nominally 2-in. (50-mm) long, 7/16-in. (11-mm) crown, 15 gage (0.072-in. (1.83-mm)) galvanized steel staples. They shall be representative of the product. Use each staple only once.

17.2.2 For determining holding ability of different types or sizes of staples in plastic lumber and shapes, the respective staples shall be representative of the normal manufacturing process, and special cleaning of the legs shall not normally be undertaken.

17.3 *Screws:*

17.3.1 Screws used for lateral tests shall be nominally 2½-in. (64-mm) No. 10-gage flathead low-carbon-steel wood screws as described in ANSI B18.6.1. Use each screw only once.

17.3.2 For determining holding ability of different sizes and types of screws in plastic lumber and shapes, the respective size and types of screw will be as circumstances dictate. These screws shall be representative of the normal manufacturing process.

18. Sampling

18.1 Tests shall be made using representative material. Cut the plastic lumber and shapes specimen to length from an “as manufactured” profile. Whenever possible, the sampling shall be on a statistical basis, and the test shall be sufficient in number to permit a statistical analysis.

NOTE 7—The precision required and thus the manner of sampling and the number of tests will depend upon the specific objective of the investigation. No general criteria, therefore, can be established. However,