



Designation: ~~D3802~~—16 D3802 – 23

Standard Test Method for Ball-Pan Hardness of Activated Carbon¹

This standard is issued under the fixed designation D3802; the number immediately following the designation indicates the year of original adoption or, in the case of revision, the year of last revision. A number in parentheses indicates the year of last reapproval. A superscript epsilon (ϵ) indicates an editorial change since the last revision or reapproval.

1. Scope

1.1 This test method covers a procedure for determining the ball-pan hardness number of granular activated carbons. For the purpose of this test, granular activated carbons are those having particles 90 % of which are larger than 80 mesh (~~180 μ m~~) (180 μ m) as determined by Test Method [D2862](#).

1.2 The values stated in SI units are to be regarded as standard. No other units of measurement are included in this standard.

1.3 *This standard does not purport to address all of the safety concerns, if any, associated with its use. It is the responsibility of the user of this standard to establish appropriate ~~safety and health~~safety, health, and environmental practices and determine the applicability of regulatory limitations prior to use.*

1.4 *This international standard was developed in accordance with internationally recognized principles on standardization established in the Decision on Principles for the Development of International Standards, Guides and Recommendations issued by the World Trade Organization Technical Barriers to Trade (TBT) Committee.*

2. Referenced Documents

2.1 ASTM Standards:²

[B19](#) Specification for Cartridge Brass Sheet, Strip, Plate, Bar, and Disks

[B150/B150M](#) Specification for Aluminum Bronze Rod, Bar, and Shapes

[D2652](#) Terminology Relating to Activated Carbon

[D2854](#) Test Method for Apparent Density of Activated Carbon

[D2862](#) Test Method for Particle Size Distribution of Granular Activated Carbon

[D2867](#) Test Methods for Moisture in Activated Carbon

[E11](#) Specification for Woven Wire Test Sieve Cloth and Test Sieves

[E300](#) Practice for Sampling Industrial Chemicals

3. Terminology

3.1 *General*—Terms applicable to this standard are defined in Terminology [D2652](#).

3.2 *Definitions of Terms Specific to This Standard:*

3.2.1 *nominal particle size: natural, granular, and irregularly shaped particle ~~carbons~~—carbons, n*—that particle size range,

¹ This test method is under the jurisdiction of ASTM Committee [D28](#) on Activated Carbon and is the direct responsibility of Subcommittee [D28.04](#) on Gas Phase Evaluation Tests.

Current edition approved ~~June 1, 2016~~ June 1, 2023. Published ~~July 2016~~ July 2023. Originally approved in 1979. Last previous edition approved in ~~2014~~ 2016 as ~~D3802—10~~ D3802 – 16. DOI: ~~10.1520/D3802-16~~ 10.1520/D3802-23.

² For referenced ASTM standards, visit the ASTM website, www.astm.org, or contact ASTM Customer Service at service@astm.org. For *Annual Book of ASTM Standards* volume information, refer to the standard's Document Summary page on the ASTM website.

TABLE 1 Hardness Test Sieve (HTS) Corresponding to Specification E11 Sieves Defining Small-End Nominal Particle Size (SNPS)

SNPS		HTS		SNPS		HTS	
Opening, mm	E11 Mesh	Opening, μm	E11 Mesh	Opening, μm	E11 Mesh	Opening, μm	E11 Mesh
5.6	3½	2800	7	850	20	425	40
4.75	4	2360	8	710	25	355	45
4.00	5	2000	10	600	30	300	50
3.35	6	1700	12	500	35	250	60
2.80	7	1400	14	425	40	212	70
2.36	8	1180	16	355	45	180	80
2.00	10	1000	18	300	50	150	100
1.70	12	850	20	250	60	125	120
1.40	14	710	25	212	70	106	140
1.18	16	600	30	180	80	90	170
1.00	18	500	35				

expressed in terms of Specification E11 sieve sizes, whose small end excludes not more than 5 % of the particle size distribution, and whose large end excludes not more than 5 % of the distribution, on a weight basis.

3.2.2 *nominal particle size: pelleted carbons—carbons, n*—that particle size range, expressed in terms of Specification E11 sieve sizes, whose small end excludes not more than 10 % of the particle size distribution, and whose large end excludes not more than 5 % of the distribution, on a weight basis.

3.2.3 *small end nominal particle size—size, n*—that particle size, expressed by its equivalent Specification E11 sieve, which defines the excluded portion of the particle size distribution at its small particle size end in accordance with 3.2.1 or 3.2.2.

4. Summary of Test Method

4.1 A screened and weighed sample of the carbon is placed in a special brass hardness pan with a specified number of stainless steel balls, then subjected to a combined rotating and tapping action for 30 min. At the end of this period, the amount of particle size degradation is determined by measuring the quantity of carbon, by weight, which is retained on a sieve whose openings are closest to one half the openings of the sieve that defines the minimum nominal particle size of the original sample.

5. Significance and Use

5.1 Several methods have been employed in the past for determining the resistance of activated carbons to particle size degradation under service conditions, including the ball-pan method, the stirring bar method, and the dust elutriation method. None of these has proved completely satisfactory for all applications, and all have been questioned by ASTM Committee D28 on Activated Carbon as tests for establishing degradation resistance. However, the ball-pan method has been used widely in the past and has a broad history in the activated carbon industry for measuring the property loosely described as “hardness.” In this context the test is useful in establishing a measurable characteristic of a carbon. Conceding the fact that the test does not actually measure in-service resistance to degradation, it can be used to establish the comparability of lots ostensibly of the same grade of carbon.

6. Apparatus and Materials

6.1 *Mechanical Sieve Shaker*, designed to produce from 140 to 160 taps and from 280 to 320 rotating motions per minute in a stack of standard Specification E11 sieves.³ The equipment is mounted securely to prevent energy loss through vibration, and must be level. Adjust the sieve shaker to accommodate the desired number of sieves, receiver pan, and sieve cover. Adjust the bottom stops to give a clearance of approximately 1.6 mm between the bottom plate and the sieves so that the sieves will be free to rotate. Fit the sieve cover plate with a cork stopper which extends from 3.23.2 mm to 9.5 mm above the metal recess. The cork is seated in the sieve cover so that it does not dampen the force of the hammer arm. Only cork is used. Run the shaker with an empty stack for >3 min to seat the cork before sample testing.

6.2 *Wire Cloth Sieves*, in accordance with Specification E11; six required, at least four of which bracket the expected nominal particle size distribution of the sample, and one of which, designated the hardness test sieve, has an opening as close as possible to one half the opening of the sieve that defines the smaller nominal particle size of the original sample. Table 1 lists the hardness

³ The sole source of supply of the apparatus (the Tyler Ro-Tap Sieve Shaker, Model RX-29) known to the committee at this time is W.S. Tyler, Inc., Gastonia, NC. If you are aware of alternative suppliers, please provide this information to ASTM International Headquarters. Your comments will receive careful consideration at a meeting of the responsible technical committee,¹ which you may attend.

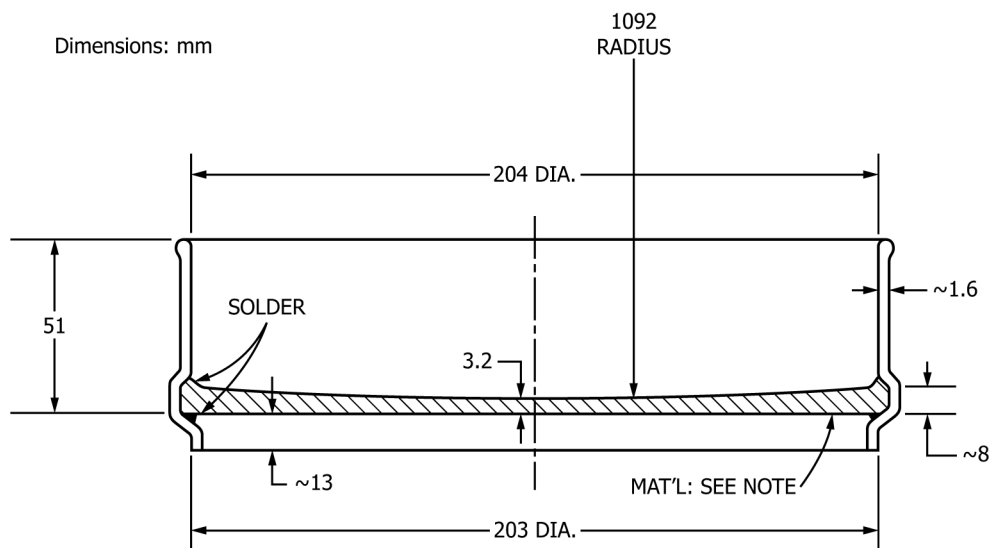

NOTE 1—Material is plate, of one of the following alloys: (1) Cartridge brass, UNS C26000, half-hard temper, hardness 60 HRB or greater (see Specification B19); or (2) Aluminum bronze, UNS C61400, soft temper, hardness 140 HB or greater (see Specification B150/B150M).

FIG. 1 Pan for Ball-Pan Hardness Test

test sieve corresponding to each minimum nominal sieve.

6.3 *Bottom Receiver Pan and Top Sieve Cover* (see 6.1).

6.4 *Pre-Conditioned Hardness Test Pan*, having the dimensions of that in Fig. 1. Ensure that the hardness pan is curved consistent with Fig. 1, where the center is lower than the sides. The hardness pan is conditioned prior to use by placing the pan and stainless steel balls into the sieve stack and subjecting it to a combined rotating and tapping action for at least 24 h. Consistent surface roughness may also be verified by internal reference material conformance.

6.5 *Adjustable Interval Timer*, with a precision of at least ± 5 s, ± 5 s, duration at least 600 s (10 min).

6.6 *Sample Splitter*, single-stage riffle type, in accordance with 30.5.2 of Practice E300.

6.7 *Balance*, with sensitivity and accuracy of at least 0.1 g.

6.8 *Soft Brass-Wire Brush*.⁴

6.9 *Steel Balls, Balls (Preferably Type 316 Stainless)*, fifteen 12.7 ± 0.1 mm solid 12.7 mm ± 0.1 mm in diameter and fifteen 9.5 ± 0.1 mm solid 9.5 mm ± 0.1 mm in diameter.

7. Sampling

7.1 Guidance in sampling granular activated carbon is given in Practice E300.

8. Calibration

8.1 Calibration of balances shall be maintained by standard laboratory methods. Sieves shall be calibrated at reasonable intervals in accordance with the procedure described in Specification E11.

⁴ The sole source of supply of the apparatus (W.S. Tyler Model 1778-SB) known to the committee at this time is W.S. Tyler, Inc., Gastonia, NC. If you are aware of alternative suppliers, please provide this information to ASTM International Headquarters. Your comments will receive careful consideration at a meeting of the responsible technical committee,¹ which you may attend.

9. Verification

9.1 Verification of mechanical sieve shaker equipment shall occur regularly, proportional to use. The height of the lift rod has a significant impact on the grinding force of the shaker and is verified relative to the equipment manufacturer's specifications.

10. Procedure

10.1 Determine the nominal particle size of the sample in accordance with Test Method **D2862**, and its moisture content in accordance with Test Methods **D2867**.

10.2 Obtain an additional representative sample of approximately 125 mL of the carbon in accordance with Practice **E300**.

10.3 Screen this sample to its nominal particle size distribution using Test Method **D2862**. Discard the fractions above the larger and below the smaller nominal particle size. Obtain at least 100 mL of material within the nominal mesh size range. Use additional material obtained as in **9-210.2**, if necessary.

10.4 Measure out 100 mL of the screened sample into a tared, graduated cylinder in accordance with Test Method **D2854**, and weigh to the nearest 0.1 g.

10.5 Place the hardness pan (**Fig. 1**) on the standard bottom receiver pan. Pour the screened and weighed sample into the hardness pan and add the steel balls.

10.6 Complete the sieve stack by stacking five full-height sieves and the sieve cover on top of the hardness pan. ~~The extra sieves, in this case, serve only to sieves form a stack which fills the shaker, thus avoiding changes in tapping action and readjustment of the sieve stack retainer.~~ maintaining weight distribution and alignment of the equipment, but do not impact the testing.

10.7 Place sieve stack in the sieve shaker ~~shaker~~, adjust the sieve stack such that the sieve cover is flush with the top of the upper carrying plate, and shake for 30 ± 0.5 min, $30 \text{ min} \pm 0.5 \text{ min}$, with tapping hammer operating.

10.8 At the end of the shaking period, remove the sieve stack from the sieve shaker and remove the hardness pan from the sieve stack. Place the hardness test sieve on top of the receiving pan.

10.9 Remove the steel balls from the hardness pan and transfer sample to the hardness test sieve, brushing adhering particles into the sieve. Stack the five full-height sieves and sieve cover on top of the hardness test sieve and receiving pan, and replace the stack in the sieve shaker. ~~Shake with the~~ Adjust the sieve stack such that the sieve cover is flush with the top of the upper carrying plate, and shake with the hammer operating for $10 \text{ min} \pm 10 \text{ s}$.

10.10 At the end of the shaking period, remove the sieve stack from the sieve shaker and transfer the remainder of the sample on the hardness test sieve to a tared weighing pan. Weigh to the nearest 0.1 g.

10.11 Sweep the pan catch into a tared weighing dish, and weigh to the nearest 0.1 g.

11. Calculation

11.1 Calculate the ball-pan hardness number from the ~~equation~~ equation:

$$H = 100 B/A \quad (1)$$

where:

H = ball-pan hardness number,

B = ~~weight of sample retained on hardness test sieve (see 9.10), g, and~~

B = weight of sample retained on hardness test sieve (see 10.10), g, and

A = ~~weight of sample loaded onto hardness pan (see 9.4), g.~~

A = weight of sample loaded onto hardness pan (see 10.4), g.