



Designation: C827/C827M – 23

Standard Test Method for Change in Height at Early Ages of Cylindrical Specimens of Cementitious Mixtures¹

This standard is issued under the fixed designation C827/C827M; the number immediately following the designation indicates the year of original adoption or, in the case of revision, the year of last revision. A number in parentheses indicates the year of last reapproval. A superscript epsilon (ϵ) indicates an editorial change since the last revision or reapproval.

1. Scope*

1.1 This test method covers the determination of change in height of cylindrical specimens from the time of molding until the mixture is hard.

1.2 This test method covers height change measurements at early ages for cementitious mixtures of paste, grout, mortar, and concrete.

1.3 This test method is intended for determination of changes in height that occur from the time of placement until the specimen is fully hard. These include shrinkage or expansion due to hydration, settlement, evaporation, and other physical and chemical effects.

1.4 The values stated in either SI units or inch-pound units are to be regarded separately as standard. The values stated in each system are not necessarily exact equivalents; therefore, to ensure conformance with the standard, each system shall be used independently of the other, and values from the two systems shall not be combined.

1.5 The text of this test method refers to notes and footnotes that provide explanatory information. These notes and footnotes shall not be considered as requirements of the test method.

1.6 *This standard does not purport to address all of the safety concerns, if any, associated with its use. It is the responsibility of the user of this standard to establish appropriate safety, health, and environmental practices and determine the applicability of regulatory limitations prior to use. (Warning—Fresh hydraulic cementitious mixtures are caustic and may cause chemical burns to exposed skin and tissue upon prolonged exposure.²)*

1.7 *This international standard was developed in accordance with internationally recognized principles on standardization established in the Decision on Principles for the*

¹ This test method is under the jurisdiction of ASTM Committee C09 on Concrete and Concrete Aggregates and is the direct responsibility of Subcommittee C09.68 on Volume Change.

Current edition approved June 15, 2023. Published July 2023. Originally approved in 1975. Last previous edition approved in 2016 as C827 – 16. DOI: 10.1520/C0827_C0827M-23.

² See Section on Safety Precautions, Manual of Aggregate and Concrete Testing, Annual Book of ASTM Standards, Vol. 04.02.

Development of International Standards, Guides and Recommendations issued by the World Trade Organization Technical Barriers to Trade (TBT) Committee.

2. Referenced Documents

2.1 *ASTM Standards:*³

C125 Terminology Relating to Concrete and Concrete Aggregates

C138/C138M Test Method for Density (Unit Weight), Yield, and Air Content (Gravimetric) of Concrete

C143/C143M Test Method for Slump of Hydraulic-Cement Concrete

C185 Test Method for Air Content of Hydraulic Cement Mortar

C191 Test Methods for Time of Setting of Hydraulic Cement by Vicat Needle

C192/C192M Practice for Making and Curing Concrete Test Specimens in the Laboratory

C305 Practice for Mechanical Mixing of Hydraulic Cement Pastes and Mortars of Plastic Consistency

C403/C403M Test Method for Time of Setting of Concrete Mixtures by Penetration Resistance

C670 Practice for Preparing Precision and Bias Statements for Test Methods for Construction Materials

C807 Test Method for Time of Setting of Hydraulic Cement Mortar by Modified Vicat Needle

C939/C939M Test Method for Flow of Grout for Preplaced-Aggregate Concrete (Flow Cone Method)

C953 Test Method for Time of Setting of Grouts for Preplaced-Aggregate Concrete in the Laboratory

C1437 Test Method for Flow of Hydraulic Cement Mortar

3. Terminology

3.1 *Definitions*—The terms used in this test method are defined in Terminology C125.

3.2 *Definitions of Terms Specific to This Standard:*

3.2.1 *early-age change in height, n*—the measured increase or decrease in height of a laterally confined cylindrical test

³ For referenced ASTM standards, visit the ASTM website, www.astm.org, or contact ASTM Customer Service at service@astm.org. For *Annual Book of ASTM Standards* volume information, refer to the standard's Document Summary page on the ASTM website.

*A Summary of Changes section appears at the end of this standard

specimen from the time of molding to when the mixture becomes hard. The user may want to define this age as the time when a companion specimen of the same batch has reached the time of final setting by Test Method C191 (paste), C953 (mortar or grout), C403/C403M (concrete), or establish a predetermined age in minutes from the time the specimen is cast as the defined age to record the final measurement. Changes in height are measured and expressed as a positive or negative change in the height of a test specimen that is restrained from lateral movement.

4. Significance and Use

4.1 This test method provides a means for comparing the relative shrinkage or expansion of cementitious mixtures. It is particularly applicable to grouting, patching, and form-filling operations where the objective is to completely fill a cavity or other defined space with a freshly mixed cementitious mixture that will continue to fill the same space at time of hardening. It would be appropriate to use this test method as a basis for prescribing mixtures having restricted or specified volume change before the mixture becomes hard.

4.2 This test method can be used for research purposes to provide information on volume changes taking place in cementitious mixtures between the time just after mixing and the time of hardening. However, the specimen used in this test method is not completely unrestrained so that the measurements are primarily useful for comparative purposes rather than as absolute values. Further, the degree of restraint to which the specimen is subjected varies with the viscosity and degree of hardening of the mixture.

5. Apparatus (see Fig. 1)

5.1 *Projected Light Source*, a lamp and a condensing lens of sufficient intensity to adequately project a light beam on a wall about 5 m [15 ft] from the light source. Protect the test specimen from heat from the light source and limit air movement (Note 1).

NOTE 1—Placing a sheet of transparent glass or plastic between the light source and the test specimens may be beneficial.

5.2 *Indicator Ball*, a spherical ball of nonabsorptive material with a density that is 55 % ± 5 % of the density of the cementitious mixture being tested, having a diameter not more than 16 mm [5/8 in.] nor less than 6 mm [1/4 in.], and composed

of materials that have no reaction with the cementitious mixture during the test period.⁴

NOTE 2—A density of approximately 1.2 Mg/m³ has been found appropriate for most uses of this test method. The density of the cementitious mixture may be calculated from values for “unit weight” obtained using Test Method C138/C138M (concrete) or C185 (mortar, grout, or paste).

5.3 *Magnifying Lens System*, a magnifying lens system such that the image of the indicator ball produced by the projected light source is cast on the indicating chart about 5 m [15 ft] away at a magnification of 90× to 110×, mounted so as not to touch the test specimen when a test is in progress (see Note 3), and having a separate magnifying lens system for each specimen tested simultaneously.

NOTE 3—One magnifying lens system that has been found acceptable consists of two lenses: a projection and a relay lens enclosed in a sealed tube. In this system, the relay lens is located nearer the test specimen and has a focal length of 50.8 mm [2 in.] and is located approximately 115 mm [4½ in.] from the indicator ball. The projection lens has a focal length of 41.4 mm [1⅝ in.], and relative aperture of f/1.6 and is 133.1 mm [5¼ in.] from the relay lens.

5.4 *Indicating Charts*, composed of stiff material approximately 600 mm [24 in.] high by 250 mm [10 in.] wide, with a white surface and a vertical black line 2 mm [1/16 in.] wide, centered and running the complete length of the chart, and a horizontal black line 1 mm [1/32 in.] in width midway on the chart, identified as the zero (0) or starting line, and 2 mm [0.1 in.] horizontal graduations above and below the zero line on the entire length of the vertical line, and a means for attaching this chart vertically and firmly to a distant wall.

5.5 *Molds*, rigid, watertight molds with a smooth interior surface made of steel, cast iron, or other nonabsorbent material nonreactive with the cementitious mixture being tested, cylindrical in shape, with internal height twice the internal diameter. Three sizes of molds are used in this test method with heights of 100 mm, 150 mm, 300 mm [4 in., 6 in., 12 in.].

5.6 *Rods*, two straight, steel tamping rods: one 10 mm [3/8 in.] in diameter and approximately 300 mm [12 in.] in

⁴ An 11 mm [7/16 in.] nylon plastic indicator ball has been found acceptable for most tests and is available from U.S. Plastics Corp., 1390 Neubrech Rd., Lima, OH 45801.

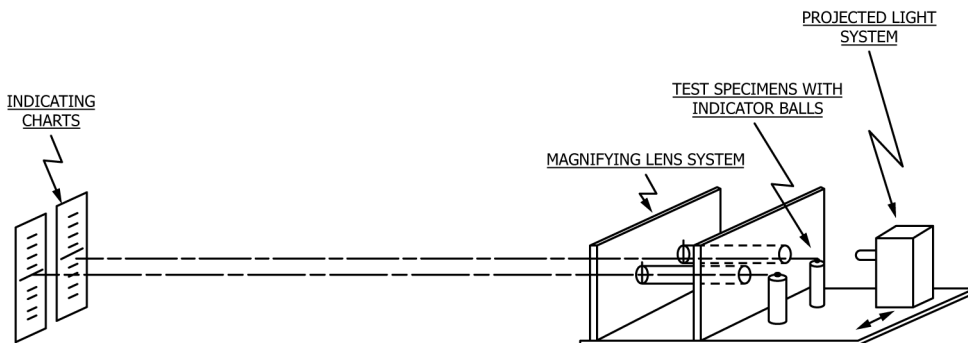

FIG. 1 Apparatus for Early Change in Height

length and the other 16 mm [$\frac{5}{8}$ in.] in diameter and approximately 600 mm [24 in.] in length. The 10 mm rod shall be used with paste, grout, and mortar. The 16 mm rod shall be used with concrete.

6. Test Specimen

6.1 Unless otherwise specified, prepare two test specimens from each batch to be tested simultaneously using duplicate test apparatus. For cement pastes, grouts, and mortars where all the aggregate will pass through a 4.75 mm (No. 4) sieve, use the 100 mm [4 in.] mold. For cementitious mixtures containing aggregate that will not all pass through a 4.75 mm sieve, but which will all pass the 12.5 mm [$\frac{1}{2}$ in.] sieve, use the 150 mm [6 in.] mold. For concrete mixtures having particles retained on the 12.5 mm [$\frac{1}{2}$ in.] sieve or larger, use the 300 mm [12 in.] mold.

7. Calibration

7.1 *General*—Minimize any sources of light not required for the tests. Locate the test equipment and specimens on a surface substantially free of vibration during the test. If desired, use a single projected light source for both test specimens with duplicate magnifying lens systems and indicating charts.

7.2 *Apparatus Calibration*—Calibrate the entire apparatus prior to the start of each test. Darken the room, illuminate the projected light source, and place the dummy test specimens (preferably hardened test specimens) in the light beam before each of the magnifying lens systems. Adjust the location of each test specimen until a sharp, clear image of the indicator ball is produced on the indicating chart. Then reposition the indicating chart so that the indicating ball image falls on the zero line. Since some magnifying lens systems result in an inverted display on the indicating charts, note whether an increase in height will be displayed on the indicating chart as a change above or below the 0 (starting) line so that the measurement data obtained during the test is interpreted correctly. Place a steel rod of known diameter (see [Note 4](#)) horizontally on top of each indicator ball and record the height of the image it produces on its respective indicating chart. The ratio of the image height to the actual rod diameter is the magnification of the lens system. Moving the projected light source, test specimen, and magnifying lens system toward or away from the indicating chart can change the magnification. Once proper magnification (90 \times to 110 \times) is obtained and the direction of height change displayed is noted, remove the dummy test specimens and do not change the relative locations of the test apparatus during the test.

NOTE 4—The shank of a 2 mm [$\frac{1}{16}$ in.] twist drill bit has been found satisfactory for most tests.

8. Preparation of Mixtures

8.1 *General*—Bring all materials to a temperature of 23 °C \pm 2.0 °C [73 °F \pm 3 °F] before mixing. Other material temperatures shall be used for this test method when specified. Proportion all materials by mass in accordance with the specifications for the cementitious mixtures to be tested.

8.2 *Mortars, Pastes, and Grouts:*

8.2.1 Either hand mix or use a suitable mechanical mixer (see [Note 5](#)) for a mixing time of 4 min, unless otherwise recommended by the manufacturer. Place all the mixing water in the mixing bowl prior to introduction of the other materials for the batch. For mortar materials that are not premixed, the sequence of mixing shall be in accordance with Practice [C305](#).

NOTE 5—The mechanical mixer described in Practice [C305](#) is a suitable mixer. However, the clearances between paddle and bowl specified in this test method are suitable only for mortars made with fine aggregates that are finer than the 850 μ m (No. 20) sieve. Mortars made with aggregates containing particles coarser than the 850 μ m sieve may require special clearances or a different type of paddle to permit the mixer to operate freely and to avoid damage to the paddle and bowl.

8.2.2 Determine the consistency of the mixtures by the flow test in accordance with the applicable provisions of Test Method [C1437](#). If this procedure is used, the flow after 5 drops of the flow table in 3 s is 145 or less. A plastic mixture should have a flow of 100 to 125, and a flowable mixture should have a flow above 125 when tested by the preceding modification of Test Method [C1437](#) but not less than 30 s when tested using the flow-cone procedure of Test Method [C939/C939M](#). A fluid mixture should have a time of efflux of 10 s to 30 s when tested by the flow-cone procedure. The water required to produce the specified consistency shall be determined by the testing of trial batches. Fresh materials shall be used to make each trial. If not specified or recommended otherwise, use sufficient mixing water to produce a flow of 135 \pm 5. For premixed mortars or grouts, use the amount of water suggested by the manufacturer for the intended application. The consistency should be determined and the values recorded for all tests.

8.3 *Concrete*—Mix concrete either manually or in a suitable laboratory mixer in accordance with the applicable provisions of Practice [C192/C192M](#). Determine the consistency of the concrete by the slump test in accordance with the applicable portions of Test Method [C143/C143M](#), and unless otherwise specified, use sufficient mixing water to produce a slump of 90 mm \pm 15 mm [$3\frac{1}{2}$ in. \pm $\frac{1}{2}$ in.].

9. Molding Specimens

9.1 Fabricate 100 mm and 150 mm [4 in. and 6 in.] specimens by filling the mold in a continuous pouring operation for pourable mixtures or in three layers with consolidation of each layer by tapping the outside of the mold ten times with a 10 mm [$\frac{3}{8}$ in.] diameter rod in the case of mixtures that are not pourable. Fabricate 300 mm [12 in.] specimens in accordance with Practice [C192/C192M](#).

9.2 Screed off the surface of the test specimen to the top of the mold. In cases where extreme shrinkage or expansion of material is anticipated, adjust the height of the test material to \pm 6 mm [$\frac{1}{4}$ in.] with respect to the mold height.

10. Procedure

10.1 Place an indicator ball in the center of the surface of each specimen. Tap the indicator ball lightly so that approximately one half of the ball's diameter penetrates the test specimen mixture. Remove pieces of large aggregate directly under the indicator balls, and repeat the procedure. Then tap the outer side of the molds lightly three times so that the