



Designation: D3681 – 23

# Standard Test Method for Chemical Resistance of “Fiberglass” (Glass–Fiber–Reinforced Thermosetting-Resin) Pipe in a Deflected Condition<sup>1</sup>

This standard is issued under the fixed designation D3681; the number immediately following the designation indicates the year of original adoption or, in the case of revision, the year of last revision. A number in parentheses indicates the year of last reapproval. A superscript epsilon ( $\epsilon$ ) indicates an editorial change since the last revision or reapproval.

## 1. Scope\*

1.1 This test method covers the procedure for determining the chemical-resistant properties of fiberglass pipe in a deflected condition for diameters 4 in. (102 mm) and larger. Both glass–fiber–reinforced thermosetting resin pipe (RTRP) and glass–fiber–reinforced polymer mortar pipe (RPMP) are fiberglass pipes.

NOTE 1—For the purposes for this standard, polymer does not include natural polymers.

1.2 Inch-pound units are to be regarded as the standard. The values given in parentheses are for information only.

1.3 *This standard does not purport to address all of the safety concerns, if any, associated with its use. It is the responsibility of the user of this standard to establish appropriate safety, health, and environmental practices and determine the applicability of regulatory limitations prior to use.* Specific precautionary statements are given in 9.5.

NOTE 2—There is no known ISO equivalent to this standard.

1.4 *This international standard was developed in accordance with internationally recognized principles on standardization established in the Decision on Principles for the Development of International Standards, Guides and Recommendations issued by the World Trade Organization Technical Barriers to Trade (TBT) Committee.*

## 2. Referenced Documents

2.1 *ASTM Standards:*<sup>2</sup>

D883 Terminology Relating to Plastics

D1600 Terminology for Abbreviated Terms Relating to Plastics

D3567 Practice for Determining Dimensions of “Fiberglass” (Glass-Fiber-Reinforced Thermosetting Resin) Pipe and Fittings

## 3. Terminology

3.1 *Definitions:*

3.1.1 *General*—Definitions are in accordance with Terminology D883 and abbreviations are in accordance with Terminology D1600 unless otherwise indicated.

3.2 *Definitions of Terms Specific to This Standard:*

3.2.1 *end point*—the passage of the fluid through the pipe wall unless otherwise stated. The failure mode may be catastrophic, characterized by a sudden fracture through the pipe wall in the area of greatest strain, parallel to the axis of the pipe, with the fiber reinforcement cleanly broken at the edge of the fracture. Visual evidence of surface etching or pitting may or may not be present.

3.2.2 *fiberglass pipe*—tubular product containing glass fiber reinforcements embedded in or surrounded by cured thermosetting resin. The composite structure may contain aggregate, granular or platelet fillers, thixotropic agents, pigments, or dyes. Thermoplastic or thermosetting liners or coatings may be included.

3.2.3 *reinforced polymer mortar pipe (RPMP)*—fiberglass pipe with aggregate.

3.2.4 *reinforced thermosetting resin pipe (RTRP)*—fiberglass pipe without aggregate.

3.2.5 *strain-corrosion*—the failure of the pipe wall caused by the exposure of the inside surface, while in a strained condition, to a corrosive environment for a period of time.

## 4. Summary of Test Method

4.1 This test method consists of exposing the interior of a minimum of 18 specimens of pipe to a corrosive test solution while the pipe is constantly maintained in a deflected condition at differing induced initial ring flexural strain levels, and measuring the time to failure for each strain level. Test temperatures are obtained by testing in an air environment where the temperature is controlled.

<sup>1</sup> This test method is under the jurisdiction of ASTM Committee D20 on Plastics and is the direct responsibility of Subcommittee D20.23 on Reinforced Thermosetting Resin Piping Systems and Chemical Equipment.

Current edition approved July 1, 2023. Published July 2023. Originally approved in 1978. Last previous edition approved in 2018 as D3681 – 18. DOI: 10.1520/D3681-23.

<sup>2</sup> For referenced ASTM standards, visit the ASTM website, www.astm.org, or contact ASTM Customer Service at service@astm.org. For *Annual Book of ASTM Standards* volume information, refer to the standard’s Document Summary page on the ASTM website.

\*A Summary of Changes section appears at the end of this standard

4.2 The long-term resistance of the pipe to the test solution is obtained by an extrapolation to 50 years of a log-log linear regression line for initial strain level versus time.

NOTE 3—It is the consensus of Subcommittee D20.23 that the log-log linear regression analysis of test data is a conservative approach and is representative of standard industry practice.

### 5. Significance and Use

5.1 This test method evaluates the effect of a chemical environment on pipe when in a deflected condition. It has been found that effects of chemical environments can be accelerated by strain induced by deflection. This information is useful and necessary for the design and application of buried fiberglass pipe.

NOTE 4—Pipe of the same diameter but of different wall thicknesses will develop different strains with the same deflection. Also, pipes having the same wall thickness but different constructions making up the wall may develop different strains with the same deflection.

### 6. Apparatus

6.1 Use parallel plate apparatus suitable to maintain a constant deflection on the pipe. In order to achieve uniform strain along the pipe, use 0.25-in. (6-mm) thick elastomeric pads between the parallel plate (channel) surfaces and the pipe ring (see Note 5). Foil type, single element strain gages suitable for strain levels to 1.50 % strain and a length appropriate to the diameter of the pipe are required when initial strain is to be determined by Procedure B (see Note 6). An example of the apparatus required is shown in Fig. 1.

NOTE 5—Elastomeric pads with a hardness of Shore A15 to 70 have been used successfully.

NOTE 6—Strain gages of ¼ and ½-in. (6 and 13-mm) length have been found to be effective for pipe diameters 12 through 24 in. (305 through 610 mm). Consult the strain gage manufacturer for gage length recommendations for other pipe diameters.

### 7. Test Specimens

7.1 The test specimens shall be ring sections taken from a sample of pipe selected at random from a normal production

run. The test specimens shall have a minimum length of one nominal pipe diameter or 12 in. (300 mm) ± 5 %, whichever is less.

### 8. Test Conditions

8.1 The standard temperature shall be 73.4 ± 3.6°F (23 ± 2°C).

### 9. Procedure

9.1 *General*—Determine the initial strain level induced in the pipe by calculation, or strain gage measurement, or both. Procedure A describes the determination of initial strain by calculation; Procedure B describes the determination of initial strain as obtained by use of foil-type resistance strain gages.

#### 9.2 Determination of Test Level:

##### 9.2.1 Test Procedure A:

9.2.1.1 In accordance with Practice D3567 measure the wall thickness to the nearest 0.001 in. (0.025 mm) in at least five equally spaced places along the bottom of the pipe specimen on a line parallel with the pipe axis, and average the measurements.

9.2.1.2 In accordance with Practice D3567 measure the vertical inside diameter to the nearest 0.01 in. (0.25 mm) at both ends prior to deflection and average the measurements.

NOTE 7—It is recommended that the vertical inside diameter be measured with the axis vertical.

9.2.1.3 Place the pipe specimen in the test apparatus (Fig. 1) with the measured wall thicknesses at the bottom and apply force to the apparatus to deflect the specimen while keeping the top and bottom plates (channels) of the apparatus as near parallel as possible. When the desired deflection is obtained, lock the apparatus to maintain the specimen in the deflected condition.

NOTE 8—Alignment of the specimen within the channels is critical. The channels shall not only be parallel with the load points 180° opposite, but the pipe shall be centered between the rods.

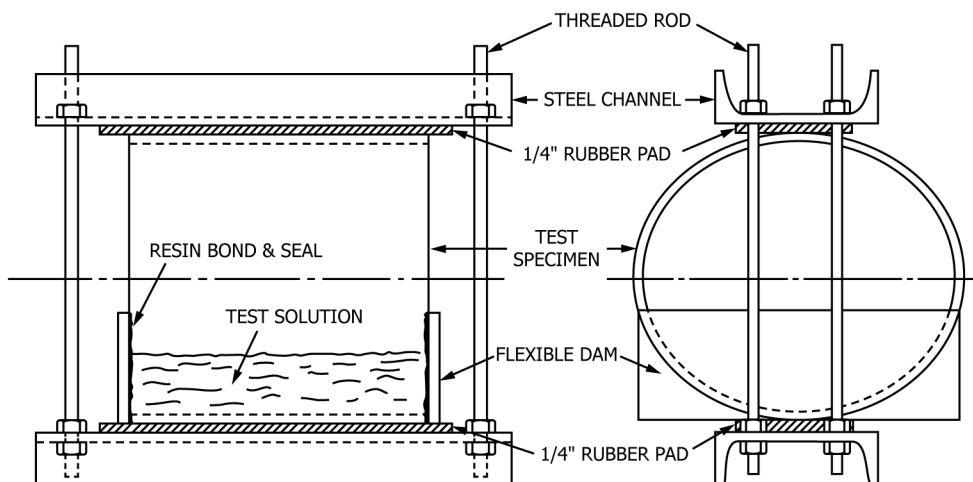

FIG. 1 Strain-Corrosion Test Apparatus

9.2.1.4 Measure the vertical inside diameter of the deflected pipe specimen at both ends to the nearest 0.01 in. (0.25 mm). Average the measurements and determine the deflection by subtracting the average vertical inside diameter after deflection from the measurement determined in 9.2.1.2.

9.2.1.5 Calculate the initial strain level using the following equation which includes compensation for increased horizontal diameter with increasing deflection.

$$\varepsilon_T = \frac{428(t)(\Delta)}{\left(D_m + \frac{\Delta}{2}\right)^2}$$

where:

- $\varepsilon_T$  = initial strain, %,
- $t$  = average wall thickness at bottom, in. (mm),
- $\Delta$  = average deflection, in. (mm),
- $D_m$  = mean diameter, in. (mm)  $\bar{D} + t$ , and
- $\bar{D}$  = average inside pipe diameter, free state, in. (mm).

NOTE 9—The calculation assumes that the neutral axis is at the pipe wall midpoint. For pipe wall constructions that produce an altered neutral axis position, it may be necessary to evaluate results substituting  $2\bar{y}$  for  $t$ . ( $\bar{y}$  is the distance from the inside pipe surface to the neutral axis.) Neutral axis position must be determined with strain gage couples. See also Note 11.

#### 9.2.2 Procedure B:

9.2.2.1 Carefully align and attach three strain gages on the inside bottom surface of the pipe specimen in the circumferential direction to measure initial circumferential strains. Place the gages perpendicular to the pipe axis as follows: one in the middle and the other two at the quarter points along the invert of the specimen. The adhesive used to attach the gages shall not cover more than 37 % of the pipe specimen length along the invert. Zero-in the gages while the pipe is circular in shape.

NOTE 10—It is recommended that the pipe specimen be placed with its axis vertical to maintain roundness when the bridge is balanced to “zero” the instrument.

9.2.2.2 After installing the strain gages, place the specimen in the test apparatus (see Fig. 1) with the strain gages at the bottom. Extreme care shall be taken to ensure that the gages are located at the point of maximum strain (6 o’clock position).

NOTE 11—Alignment of the specimen within the channels is critical. The channels shall not only be parallel with the load points 180° opposite, but the pipe shall be centered between the rods.

9.2.2.3 Apply force to the apparatus to deflect the specimen while keeping the top and bottom plates (channels) of the apparatus as parallel as possible. When the desired strain level is reached, lock the apparatus to maintain the specimen in the deflected condition. Read the gages as soon as the apparatus is locked. Initial strain shall be recorded within 2 min after locking the apparatus. At least two gages shall read within 5 % of each other for a valid experiment. If any gage reads more than 5 % from the average of the other two gages, disregard the indication unless thickness verification implies the strain gage reading was accurate. Average the valid gage indications, and record as initial (indicated) strain. In addition, measure and record the deflection.

9.3 When using Procedure A, verify the strain level by using strain gages as described in Procedure B for at least one specimen in every nine. Conversely, when using Procedure B, verify the strain level by measurement and calculation as described in Procedure A for at least one specimen in every nine. If the calculated strain and the indicated strain do not vary more than 10 %, consider the strain levels accurate within normal experimental error.

NOTE 12—Deflections in excess of 28 % of diameter may cause local flattening of the pipe and lead to erratic strain distribution. For deflections approaching 28 % improved accuracy is obtained by use of strain gages or by establishing, for a typical pipe, a calibration of deflection versus measured strain. This calibration technique is also useful at all deflection levels as a check of the calculations by 9.2.1.5, which assumes neutral axis at pipe wall midpoint.

9.4 After the initial strain is obtained using Procedure A or B, install chemically inert dams using a flexible sealant so that only the interior surface of the pipe will be exposed to the test environment. The dams shall not add support to the pipe specimen.

9.5 Place the apparatus containing the specimen in a chemically resistant trough or pan and introduce the test solution. Care should be taken to work quickly, and the solution shall be added within a maximum of 30 minutes of locking the apparatus. The time shall be recorded from the addition of the solution. (**Warning**—Since the failure mode could be catastrophic, precautions should be taken to contain any sudden leakage that may occur. The use of spacers (such as, wooden blocks) under the apparatus is suggested to reduce attack of the apparatus after failure of the sample.)

NOTE 13—Especially for tests with expected short time-to-failure (that is, high strain tests), it is important to add the test solution quickly to obtain the most accurate and consistent results.

9.6 Periodically check and maintain the test solution within  $\pm 5\%$  of the specified strength or concentration for the duration of the test. Maintain the level at a depth of not less than 1 in. (25.4 mm) during the period of the test.

NOTE 14—As some solutions become more concentrated with the evaporation of water, care must be exercised in replenishment to prevent a build-up in strength. It may be necessary, with some reagents, to periodically clean the deflected specimen and replace the test solution with a fresh mixture. The use of plastic film, cut carefully to fit between the dams and floated on the top of the test solution, has been found helpful in reducing evaporation.

9.7 Record the following data:

- 9.7.1 Average pipe wall thickness,
- 9.7.2 Average inside pipe diameter before deflection,
- 9.7.3 Average inside pipe diameter after deflection,
- 9.7.4 Percent deflection,
- 9.7.5 Initial strain and method of determination,
- 9.7.6 Type, location, and time of any distress of the pipe wall, and
- 9.7.7 Time to end point. Times are measured from the addition of solution.

9.8 To determine the regression line and the lower confidence level for the report, a minimum of 18 samples is required. Distribution of data points shall be as follows:

Hours	Failure Points
10 to 1000	at least 4
1000 to 6000	at least 3
After 6000	at least 3
After 10 000	at least 1

9.9 Perform inspection of the test samples as follows:

Hours	Inspect at Least
10 to 20	every 1 h
20 to 40	every 2 h
40 to 60	every 4 h
60 to 100	every 8 h
100 to 600	every 24 h
600 to 6000	every 48 h
After 6000	every week

Record the time to end point for each specimen.

NOTE 15—The use of electronic timers is considered highly desirable in monitoring failure time particularly on short term tests.

9.10 Analyze the test results by using for each specimen, the logarithm of the strain in percent and the logarithm of the time-to-failure in hours as described in Annex A1. Calculate the strain at 50 years (YL).

9.11 Those specimens that have not failed after more than 10 000 h are permitted to be included as failures to establish the regression line. Use of these data points may result in a lower or higher extrapolated strain. In either case the requirements of 9.14 must be satisfied.

NOTE 16—Non-failed specimens may be left under test and the regression line recalculated as failures are obtained.

9.12 Determine the final line for extrapolation to 50 years by the method of least squares given in Annex A1, using all end points along with those non-failure points selected by the method described in 9.11. Calculate  $S_{xy}$  in accordance with A1.4.2 and the coefficient of correlation,  $r$ , in accordance with A1.4.3.

9.13 If  $S_{xy}$  is greater than 0 (see A1.4.2), consider the data unsuitable.

9.14 If the coefficient of correlation value (see A1.4.3),  $r$ , is less than the applicable minimum value given in Table A1.1 as a function of  $n$ , reject the data.

9.15 Prepare a graph on a log-log diagram in accordance with 9.12 showing time to failure versus strain, with time plotted on the horizontal ( $x$ ) axis and strain plotted on the vertical ( $y$ ) axis.

## 10. Reconfirmation of Strain Corrosion Regression Line

10.1 When a piping product has an existing strain corrosion regression line, any change in material, manufacturing process, construction, or liner shall necessitate a screening evaluation (reconfirmation) as described in 10.2, 10.3, 10.4, and 10.5.

10.2 Calculate and plot the 95 % confidence limits and the 95 % prediction limits of the original regression line in accordance with A1.4 using only data obtained prior to the change.

NOTE 17—Prediction limits define the bounds for single observations, whereas confidence limits define the bounds for the regression line.

NOTE 18—For 95 % confidence limits, there is a 2.5 % probability that the mean value for the regression line may fall above the UCL and a 2.5 % probability that the mean value for the regression line may fall below the

LCL. For 95 % prediction limits, there is a 2.5 % probability that individual data points may fall above the UPL and a 2.5 % probability that individual data points may fall below the LPL.

10.3 From the original regression line, select strain levels for at least two sets of specimens, each set consisting of three or more specimens each to be tested at the same strain level as follows:

Hours to Failure (Average of Set)	Failure Points
10 to 200	at least 3
More than 1000	at least 3
Total:	at least 6

For the purpose of reconfirmation, it is permitted to include as failures those specimens which have not failed after 1200 hours provided they exceed the regression line.

10.4 Consider any changes in material or manufacturing process minor and permissible if the results of 10.3 meet the following criteria.

10.4.1 The average time to failure for each strain level falls on or above the 95 % lower confidence limit of the original regression line.

10.4.2 The earliest individual failure time at each strain level falls on or above the 95 % lower prediction limit of the original regression line.

10.4.3 The failure points are distributed about the originally determined regression line. No more than two-thirds of the individual failure points may fall below the original regression line.

10.5 It is permitted to assume that data meeting the criteria of 10.4 are part of the original data set and a new regression line determined using all failure points. Specimens that have not failed after 1200 hours are not suitable for establishing a new regression line; however, it is permitted to use these data points for the purpose of reconfirmation.

10.6 If the data fails to satisfy the criteria of 10.4.1, the changes are considered major and a new regression line must be established. While the new test program is being conducted, an interim strain corrosion value for the material or process change may be taken as the lower of:

10.6.1 The 95 % lower confidence limit of the value obtained by extrapolating the failure points of 10.3 to 438 000 h (50 years) by the procedure in Annex A1.

10.6.2 The 95 % lower confidence limit of the original regression line at 50 years.

## 11. Report

11.1 The report shall include the following:

11.1.1 Complete identification of the pipe composition, manufacturer's code, size, and minimum wall thickness.

11.1.2 Test procedure used.

11.1.3 Data in 9.7.

11.1.4 Notations of any type of distress observed in the specimens, whether it be discoloration, leakage, small fracture, surface crazing, or complete cracking, together with the time and date of occurrence, and the location of distress. Indicate the location of distress using the bottom center as the reference point.

11.1.5 Complete description of the test solution (reagent).



11.1.6 Type of strain gage employed and method of mounting.

11.1.7 Temperature at which the test was run.

11.1.8 Graph of 9.15.

11.1.9 Strains at 50 years.

11.1.10 Coefficient of correlation,  $r$  (see 9.12).

**12. Precision and Bias**

12.1 No precision and bias statement can be made for this test method since controlled round-robin test programs have

not been run. This test method is generally used to evaluate large-diameter fiberglass pipe.

**13. Keywords**

13.1 chemical resistance; constant deflection; extrapolation; fiberglass pipe; regression line; strain-corrosion

**ANNEX**

**(Mandatory Information)**

**A1. LEAST SQUARES CALCULATION FOR LONG TERM STRAIN CORROSION VALUE**

**A1.1 General**

A1.1.1 The analysis is based on the following relationship:

$$y = a + bx \tag{A1.1}$$

where:

$y$  = one variable,

$x$  = the other variable

$b$  = the slope of the line, and

$a$  = the intercept on the  $y$  axis.

A1.1.2 A linear functional relationship analysis (sometimes called “covariance analysis”) is used, subject to tests for the sign (that is, “+” or “-”) of the slope and the coefficient of correlation for the quantity of data available. The relevant equations are given together with example data and results, on the basis of which any other statistical computing package may be used subject to validation by agreement with the example results to within the indicated limits.

A1.1.3 For the purposes of this annex, a design service life of 50 years has been assumed.

**A1.2 Procedure for Analysis of Data**

A1.2.1 Use a linear functional relationship analysis to analyze  $n$  pairs of data values (as  $y$  and  $x$ ) to obtain the following information:

A1.2.1.1 The slope of line,  $b$ ,

A1.2.1.2 The intercept on the  $y$  axis,  $a$ ,

A1.2.1.3 The correlation coefficient,  $r$ , and

A1.2.1.4 The predicted mean and the lower 95 % confidence and prediction intervals on the mean value.

**A1.3 Assignment of Variables**

A1.3.1 Let  $x$  be  $\log_{10}t$ , where  $t$  is the time, in hours, and let  $y$  be  $\log_{10}V$ , where  $V$  is the strain value.

**A1.4 Functional Relationship Equations and Method of Calculation**

A1.4.1 *Basic Statistics and Symbols:*

A1.4.1.1 The following basic statistics and symbols are used:

$n$  = the number of pairs of observed data values ( $V_i, t_i$ ),

$y_i$  = the  $\log_{10}$  of  $V_i$ , where  $V_i$  is the strain at failure of observation  $i$ ;  $i = 1, \dots, n$ ,

$x_i$  = the  $\log_{10}$  of  $t_i$ , where  $t_i$  is the time to failure (in hours) of observation  $i$ ;  $i = 1, \dots, n$ ,

$\bar{y}$  = the arithmetic mean of all  $y_i$  values:

$$\bar{y} = \frac{1}{n} \sum y_i \tag{A1.2}$$

$\bar{x}$  = the arithmetic mean of all  $x_i$  values:

$$\bar{x} = \frac{1}{n} \sum x_i \tag{A1.3}$$

**A1.4.2 Relevant Sums-of-Squares:**

A1.4.2.1 Calculate the following sums-of-squares and cross-products:

$$S_{xy} = \frac{1}{n} \sum (x_i - \bar{x})(y_i - \bar{y}) \tag{A1.4}$$

A1.4.2.2 If  $S_{xy} > 0$ , consider the data unsuitable for evaluating the material; otherwise, calculate also:

$$S_{xx} = \frac{1}{n} \sum (x_i - \bar{x})^2 \tag{A1.5}$$

$$S_{yy} = \frac{1}{n} \sum (y_i - \bar{y})^2 \tag{A1.6}$$

**A1.4.3 Correlation of Data:**

A1.4.3.1 Calculate the coefficient of correlation,  $r$ , from the following relationship:

$$r^2 = \frac{(S_{xy})^2}{(S_{xx} \times S_{yy})} \tag{A1.7}$$

$$r = \sqrt{r^2}$$

A1.4.3.2 If the value of  $r$  is less than the applicable minimum value given in Table A1.1 as a function of  $n$ , reject the data; otherwise, proceed to A1.4.4.