



Designation: ~~D6082~~—~~22~~ D6082 – 23

Standard Test Method for High Temperature Foaming Characteristics of Lubricating Oils¹

This standard is issued under the fixed designation D6082; the number immediately following the designation indicates the year of original adoption or, in the case of revision, the year of last revision. A number in parentheses indicates the year of last reappraisal. A superscript epsilon (ϵ) indicates an editorial change since the last revision or reappraisal.

1. Scope*

1.1 This test method covers the procedure for determining the foaming characteristics of lubricating oils (specifically transmission fluid and motor oil) at 150 °C.

1.2 Foaming characteristics of lubricating oils at temperatures up to 93.5 °C are determined by Test Method ~~D892~~ or IP 146.

1.3 The values stated in SI units are to be regarded as standard.

1.3.1 *Exception*—The values given in parentheses are provided for information only.

1.4 **WARNING**—Mercury has been designated by many regulatory agencies as a hazardous substance that can cause serious medical issues. Mercury, or its vapor, has been demonstrated to be hazardous to health and corrosive to materials. Use caution when handling mercury and mercury-containing products. See the applicable product Safety Data Sheet (SDS) for additional information. The potential exists that selling mercury or mercury-containing products, or both, is prohibited by local or national law. Users must determine legality of sales in their location. ~~D6082-23~~

1.5 *This standard does not purport to address all of the safety concerns, if any, associated with its use. It is the responsibility of the user of this standard to establish appropriate safety, health, and environmental practices and determine the applicability of regulatory limitations prior to use.*

1.6 *This international standard was developed in accordance with internationally recognized principles on standardization established in the Decision on Principles for the Development of International Standards, Guides and Recommendations issued by the World Trade Organization Technical Barriers to Trade (TBT) Committee.*

2. Referenced Documents

2.1 ASTM Standards:²

[D892 Test Method for Foaming Characteristics of Lubricating Oils](#)

[D4175 Terminology Relating to Petroleum Products, Liquid Fuels, and Lubricants](#)

[E128 Test Method for Maximum Pore Diameter and Permeability of Rigid Porous Filters for Laboratory Use](#)

[E1272 Specification for Laboratory Glass Graduated Cylinders](#)

¹ This test method is under the jurisdiction of ASTM Committee [D02](#) on Petroleum Products, Liquid Fuels, and Lubricants and is the direct responsibility of Subcommittee [D02.06](#) on Analysis of Liquid Fuels and Lubricants.

Current edition approved Nov. 1, 2022; July 1, 2023. Published November 2022; July 2023. Originally approved in 1997. Last previous edition approved in 2017 as ~~D6082-12~~ (2017); ~~D6082-22~~. DOI: ~~10.1520/D6082-22~~; [10.1520/D6082-23](#).

² For referenced ASTM standards, visit the ASTM website, [www.astm.org](#), or contact ASTM Customer Service at [service@astm.org](#). For *Annual Book of ASTM Standards* volume information, refer to the standard's Document Summary page on the ASTM website.

*A Summary of Changes section appears at the end of this standard

2.2 Energy Institute Standards:³

IP 146 Standard Method of Test for Foaming Characteristics of Lubricating Oils

3. Terminology

3.1 Definitions:

3.1.1 For definitions of terms used in this test method, refer to Terminology [D4175](#).

3.1.2 *diffuser*, *n*—for gas, a device for dispersing gas into a liquid (Test Method [D892](#)).

3.1.2.1 Discussion—

Although diffusers can be made of either metallic or non-metallic materials, in this test method the diffuser is sintered stainless steel.

3.1.3 *entrained air (or gas)*, *n*—in liquids, a two-phase mixture of air (or gas) dispersed in a liquid in which the liquid is the major component on a volumetric basis.

3.1.3.1 Discussion—

The air (or gas) is in the form of discrete bubbles of about 10 µm to 1000 µm in diameter. The bubbles are not uniformly dispersed. In time, they rise to the surface to coalesce to form larger bubbles which break or form foam. Subsurface coalescence can also occur, in which case, the bubbles will rise more rapidly.

3.1.4 *foam*, *n*—in liquids, a collection of bubbles formed in or on the surface of a liquid in which the air or gas is the major component on a volumetric basis.

3.1.5 *gas*, *n*—a fluid (such as air) that has neither independent shape nor volume but tends to expand indefinitely.

3.1.6 *lubricant*, *n*—any material interposed between two surfaces that reduces friction or wear between them.

3.1.6.1 Discussion—

In this test method, the lubricant is an oil which may or may not contain additives such as foam inhibitors.

3.1.7 *maximum pore diameter*, *n*—in gas diffusion, the diameter of a capillary of circular cross-section which is equivalent (with respect to surface tension effects) to the largest pore of the diffuser under consideration. The pore dimension is expressed in micrometers (µm).

3.1.8 *permeability*, *n*—in gas diffusion, the rate of a substance that passes through a material (diffuser) under given conditions.

3.2 Definitions of Terms Specific to This Standard:

3.2.1 *bottom volume*, *n*—the volume of liquid sample, that is, sample substantially free of air, at any given time during the test.

3.2.2 *collapse time*, *n*—in foam testing, the time in seconds, for zero foam to appear after the air is disconnected at the end of the five minute air blowing time.

3.2.3 *dynamic bubble*, *n*—the first bubble to pass through and escape from the diffuser followed by a continuous succession of bubbles when testing for the pore diameter in [Annex A1](#).

3.2.3.1 Discussion—

When a diffuser is immersed in a liquid such as propan-2-ol, air can be trapped in the pores. It can escape eventually or as soon as a pressure is applied to the diffuser. When testing for pore diameter ([Annex A1](#)), the escape of such bubbles is to be ignored.

3.2.4 *foam stability*, *n*—in foam testing, the amount of static foam remaining at specified times following the disconnecting of the air supply.

3.2.4.1 *five-second foam stability*, *n*—the amount of static foam present 5 s after disconnecting the air supply.

3.2.4.2 *fifteen-second foam stability*, *n*—the amount of static foam present 15 s after disconnecting the air supply.

3.2.4.3 *one-minute foam stability*, *n*—the amount of static foam present 1 min after disconnecting the air supply.

³ Available from Energy Institute, 61 New Cavendish St., London, WIG 7AR, U.K., <http://www.energyinst.org.uk>.

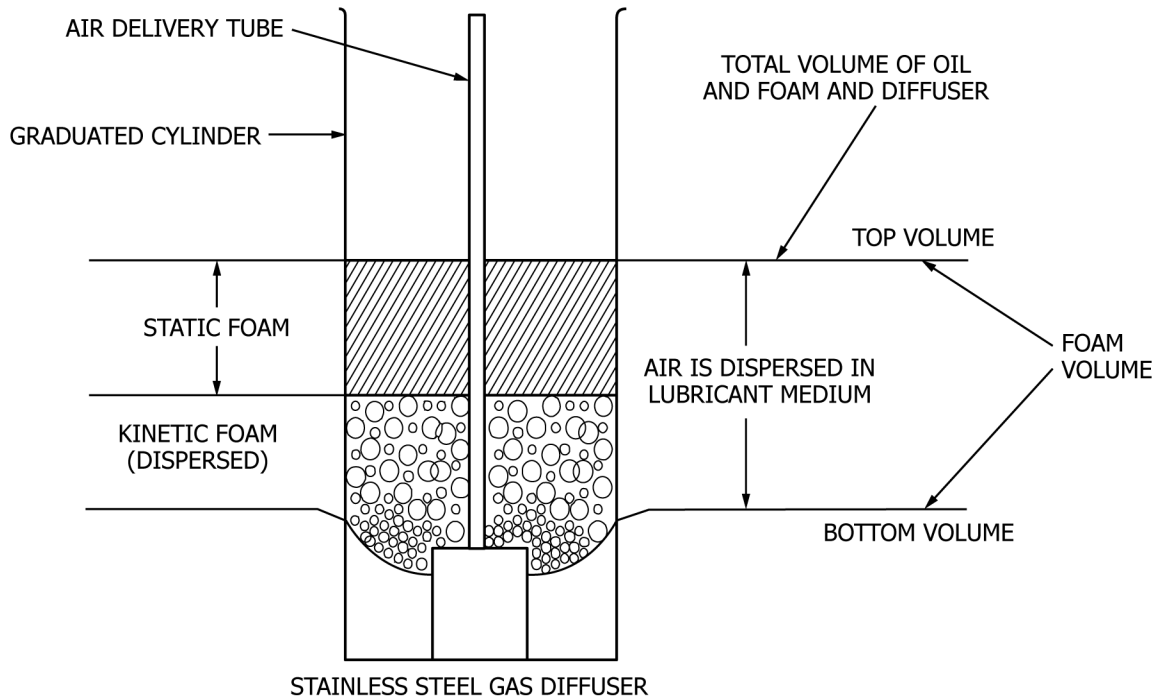

FIG. 1 Terminology Diagram

3.2.4.4 *five-minute foam stability, n*—the amount of static foam present 5 min after disconnecting the air supply.

3.2.4.5 *ten-minute foam stability, n*—the amount of static foam present 10 min after disconnecting the air supply.

3.2.5 *foaming tendency, n*—in foam testing, the amount of static foam immediately before the cessation of air flow.

3.2.6 *kinetic foam, n*—entrained air that has been created by the passage of air through the diffuser during the test (see Fig. 1).

3.2.6.1 *Discussion*—

Because the process of passing air through the diffuser and the oil sample during the test has resulted in an increase in volume and because such entrained air can be considered as foam on its way to being made, the term kinetic foam has been introduced.

3.2.7 *percent volume increase, n*—in foam testing, the increase in total volume expressed as a percentage of the initial total volume with diffuser in place at test temperature.

3.2.8 *static foam, n*—foam that has been created by the passage of air through the diffuser during the test (see Fig. 1).

3.2.9 *top volume, n*—the volume of the foam (if any), liquid, diffuser, and the submersed portion of the delivery tube (see Fig. 1).

3.2.10 *total volume, n*—in foam testing, the volume of foam, liquid, diffuser, and submersed portion of delivery tube (see Fig. 1).

3.2.10.1 *initial total volume (V_1), n*—in foam testing, the volume of the foam, liquid, diffuser, and submersed portion of the delivery tube at test temperature prior to connecting the air supply.

3.2.10.2 *final total volume (V_2), n*—in foam testing, the volume of the foam, liquid, diffuser, and submersed portion of the delivery tube just before disconnecting the air supply.

3.2.11 *zero foam, n*—in foam testing, occurs when any portion of the top surface of the liquid is free of bubbles.

4. Summary of Test Method

4.1 A measured quantity of sample is heated to 49 °C for 30 min and allowed to cool to room temperature. The sample is transferred to a 1000 mL graduated cylinder, heated to 150 °C, and aerated at 200 mL/min with dry air for 5 min with a metal

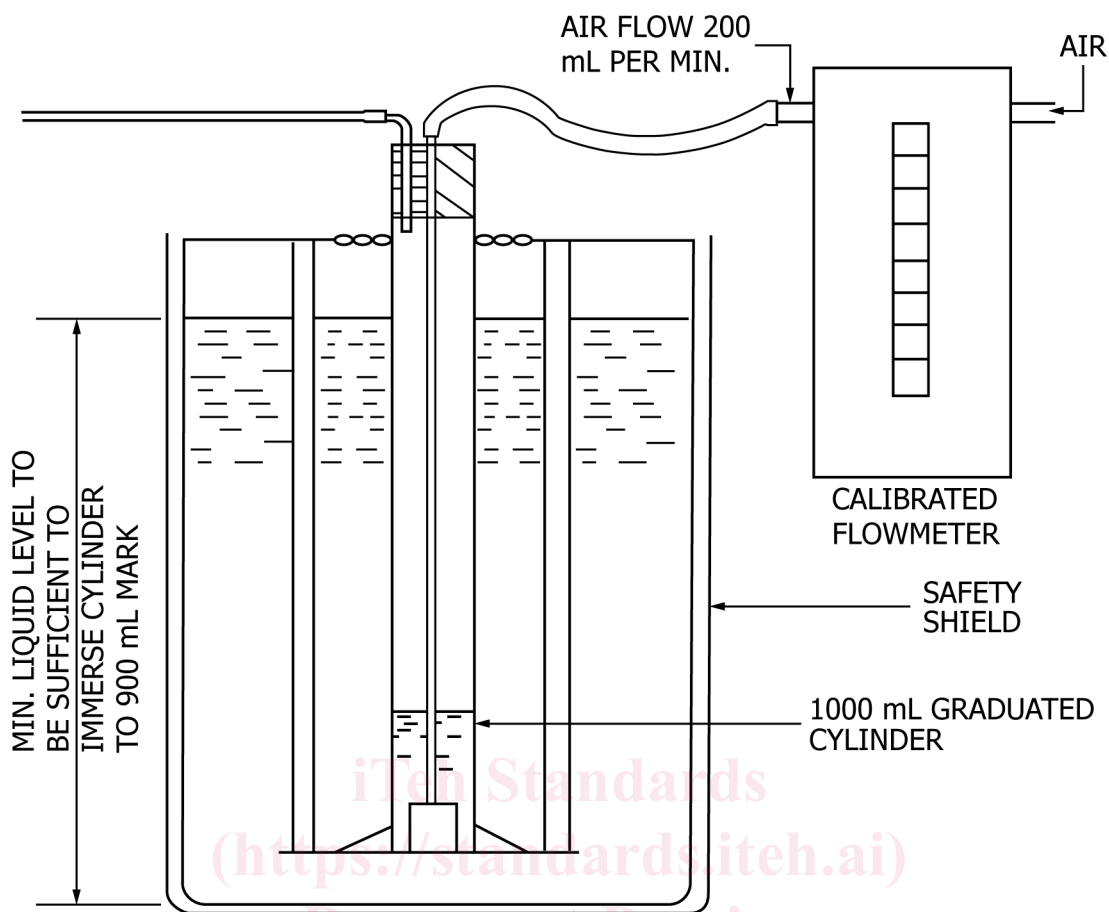

FIG. 2 Typical Liquid Bath

diffuser. The amount of foam generated before disconnecting the air, the amount of static foam at optional times after disconnecting the air (list of options in Section 10); and the time for the foam to collapse are measured and the percent increase in total volume calculated.

5. Significance and Use

5.1 The tendency of oils to foam at high temperature can be a serious problem in systems such as high-speed gearing, high volume pumping, and splash lubrication. Foaming can cause inadequate lubrication, cavitation, and loss of lubricant due to overflow, and these events can lead to mechanical failure.

5.2 Correlation between the amount of foam created or the time for foam to collapse, or both, and actual lubrication failure has not been established. Such relations should be empirically determined for foam sensitive applications.

6. Apparatus

6.1 *Heating Bath*, any heating system capable of maintaining a sample temperature of $150\text{ }^{\circ}\text{C} \pm 1\text{ }^{\circ}\text{C}$ (see Fig. 2).

NOTE 1—The precision of this test method was determined using only liquid baths.

6.1.1 *Heating Transfer Fluid*, any liquid with low volatility, at the test temperature, chemical stability and sufficient low viscosity to permit stirring.

NOTE 2—A $4\text{ mm}^2/\text{s}$ to $7\text{ mm}^2/\text{s}$ (cSt) polyalphaolefin has been found to be a suitable fluid. Silicone fluids are foam inhibitors and their use may alter the foam characteristics of the test sample and should be discouraged.

NOTE 3—A slow purge of nitrogen gas through the fluid, or as a blanket over the bath fluid, reduces darkening (oxidation) of the bath fluid.

6.2 *Foaming Test Apparatus*, 1000 mL graduated cylinder (of cylinders meeting Specification E1272 Class B tolerance requirement of ± 6 mL and having at least graduations of 10 mL), fitted with a device to overcome buoyancy if a liquid bath is used and modified to have a circular top. It shall be capable of withstanding the extreme temperature conditions of this test method.

NOTE 4—It may be necessary to confirm the volume of the cylinder.

NOTE 5—A heavy metal ring large enough to fit over the outside and rest on the bottom of the cylinder has been found to be suitable to overcome buoyancy.

NOTE 6—Graduated cylinders having a pouring spout can be prepared for this test method by making a horizontal cut below the spout and removing the part above the cut. The cut edges of the cylinder should be fire-polished or smoothed by grinding.

6.3 *Flow Meter and Regulator*, calibrated and capable of maintaining air flow volume of 200 mL/min \pm 5 mL/min.

6.3.1 A gas volume meter graduated in hundredths of a litre, or a technically equivalent flow measuring device, with sufficient capacity to measure a flow rate of at least 6000 mL/min, while generating a back pressure of no more than 10 mm of water, is required.

6.4 *Laboratory Oven*, without fan, capable of maintaining 49 °C \pm 1 °C.

6.5 *Stirrer*, capable of 500 r/min \pm 100 r/min, fitted with a 3.81 cm, 3-blade, 1.5-pitch marine propeller.

6.6 *Stainless Steel Diffuser*, 5 μ m stainless steel diffuser meeting the specifications of pore size 15 μ m to 60 μ m and permeability between 3000 mL/min to 6000 mL/min when tested according to the method given in Annex A1 (see Fig. 3).

6.6.1 Calibration verification of new diffusers and calibration after each set (10 samples or less) of evaluations is required.

6.7 *Thermometer*, or other temperature sensing device capable of measuring 150 °C \pm 0.2 °C.

6.7.1 Digital thermometers with a minimum accuracy of 0.1 % of reading 0.5 °C (1 °F) with 0.1° resolution throughout range, and J, K, and T type thermocouples probe style compatible have been found suitable for operation with either liquid or air foam baths.

6.7.2 A low noise iron-constantan J type thermocouple probe 457 mm (18 in.) in length, constructed of a 304 s/s sheath, with a glass-filled nylon connector body rated from -29 °C to 220 °C immersed in the sample at a minimum of 100 mm has been found suitable for operation with either liquid or air foam baths.

6.8 *Timing Device*, capable of measuring minutes and seconds (± 1 s).

6.9 *High Speed Blender*, with a container capacity of one litre, capable of maintaining a speed of 22 000 r/min (± 2000).

7. Reagents

7.1 *Purity of Reagents*—Reagent grade chemicals shall be used in all tests. Unless otherwise indicated, it is intended that all reagents conform to the specifications of the Committee on Analytical Reagents of the American Chemical Society where such specifications are available.⁴ Other grades may be used, provided it is first ascertained that the reagent is of sufficiently high purity to permit its use without lessening the accuracy of the determination.

7.2 *Acetone*, (**Warning**—Extremely flammable. Vapors may cause flash fire.)

7.3 *Compressed Air*, hydrocarbon free and dry to a dew point of -60 °C or lower.

⁴ ACS Reagent Chemicals, Specifications and Procedures for Reagents and Standard-Grade Reference Materials, American Chemical Society, Washington, DC. For suggestions on the testing of reagents not listed by the American Chemical Society, see *Analar Standards for Laboratory Chemicals*, BDH Ltd., Poole, Dorset, U.K., and the *United States Pharmacopeia and National Formulary*, U.S. Pharmacopeial Convention, Inc. (USPC), Rockville, MD.

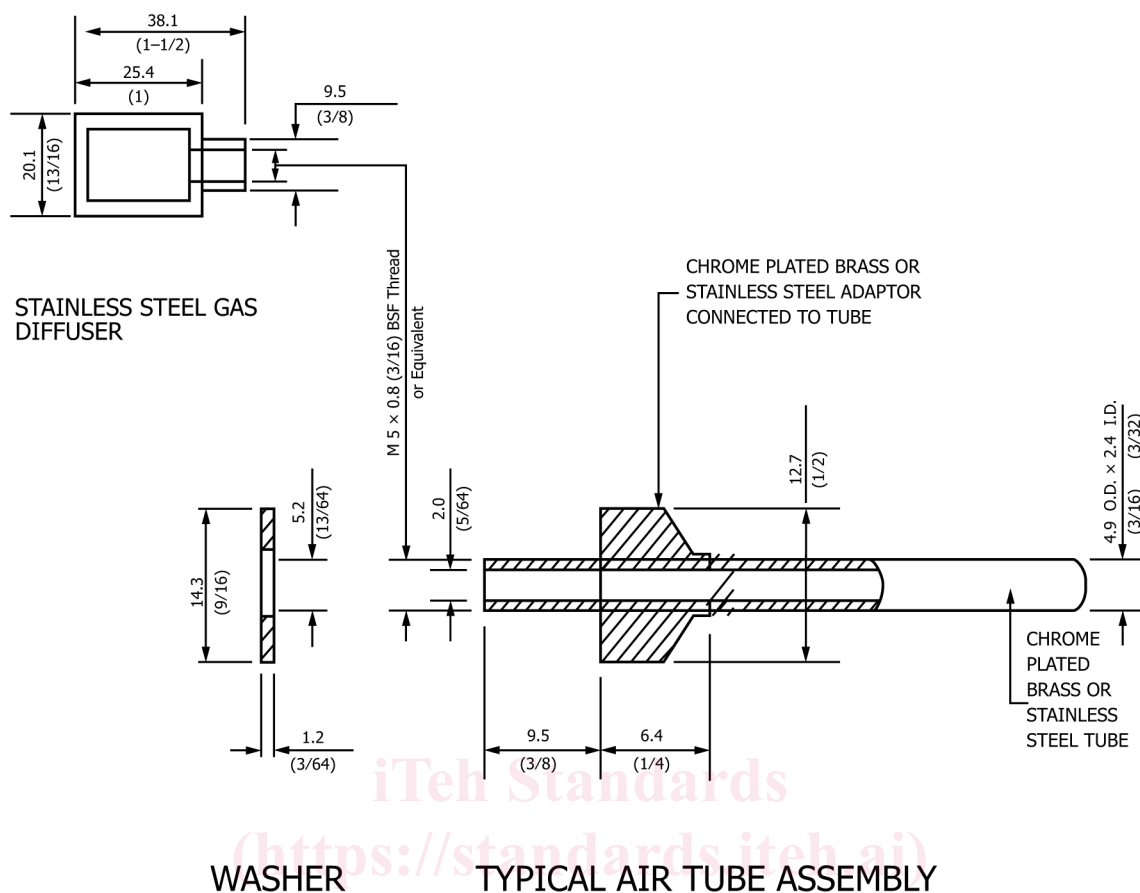

Dimensions are $\frac{\text{Millimeters}}{\text{(Inches)}}$ D6082-23

<https://standards.iteh.ai/catalog/standards/sist/f64993d3-5ee9-41c0-a676-be06e367c2f2/astm-d6082-23>
FIG. 3 Gas Diffuser and Air Tube Dimensions

7.4 *Heptane*, (**Warning**—Flammable. Vapor harmful.)

7.5 *Propan-2-ol*, (**Warning**—Flammable. Vapor harmful.)

7.6 *Toluene*, (**Warning**—Flammable. Vapor harmful.)

NOTE 7—Solvents with equivalent cleaning characteristics can be substituted for toluene.

8. Hazards

8.1 (**Warning**—Users of this test method shall be fully trained and familiar with all normal laboratory practice, or under the immediate supervision of such a person. It is the responsibility of the operator to ensure that all local legislative and statutory requirements are met.)

8.2 (**Warning**—Cleaning solvents have flash points lower than usual laboratory ambient temperatures. Avoid the possibility of a fire or explosion.)

8.3 (**Warning**—The fumes from the test oil and bath must be vented in a manner compatible with local environmental regulations.)

8.4 (**Warning**—Some apparatus assemblies can have as much as 20 L of bath oil at 150 °C. Therefore, in the event of a breakage of the containing vessel, suitable containment of the spill is advisable.)

9. Preparation of Apparatus

9.1 Thorough cleansing of the test cylinder, gas diffuser, and air-inlet tube is essential after each use to remove any additive remaining from previous tests which can seriously interfere with results of subsequent tests.

9.1.1 *Cylinder*—Rinse the cylinder with heptane (**Warning**—Flammable. Vapor harmful), followed by directing a current of compressed air into the cylinder. Wash the cylinder with a suitable detergent. Rinse the cylinder in turn with distilled water, then acetone (**Warning**—Extremely flammable. Vapors may cause flash fire), and dry with a current of compressed air or in a drying oven. Interior cylinder walls that drain distilled water cleanly, that is without drops forming, are adequately cleaned.

NOTE 8—Certain detergents are notorious for adhering to glass, therefore it is important to realize that such a circumstance can affect the test result. Several rinsings with water and acetone may be required.

9.1.2 *Gas Diffuser and Air Tube*—Clean the gas diffuser by washing it with toluene (**Warning**—Flammable. Vapor harmful) and heptane. Immerse the gas diffuser in about 300 mL of toluene. Flush a portion of the toluene back and forth through the gas diffuser at least five times with vacuum and air pressure. Repeat the process with heptane. After the final washing, dry both tube and gas diffuser thoroughly by forcing clean air through them. Wipe the outside of the air-inlet tube first with toluene, then with a clean cloth moistened with heptane, and finally with a clean dry cloth. Do not wipe the diffuser.

NOTE 9—Certain samples may contain ingredients which may not be adequately removed by this process and, because these can affect the next test, more rigorous cleaning may be required; this is recommended. When alternate diffuser cleaning methods are used certain cautions should be observed: (1) Non-metallic diffusers may have absorbed as well as adsorbed these interfering ingredients or the cleaners, or both, and this shall be considered before proceeding to the next test; (2) So that all tests performed start off under the same circumstances, when alternate diffuser cleaning methods are used, the final rinsing process shall be as detailed in 9.1.2; (3) See also Note 1. Gas diffuser permeability and porosity can change during use; therefore it is recommended that diffusers be tested when new and periodically thereafter, preferably after each use.

NOTE 10—It is useful to measure the total exit air volume to detect leaks in the system. See Test Method D892 for details of this apparatus.

10. Procedure

10.1 Proceed to 10.2.1 if optional blending is explicitly required by the lubricant specification (see Note 11).

NOTE 11—Lubricant specifications that require optional blending use the term “Option A” to identify this process.

10.2 Vigorously hand shake the container for 1 min before decanting approximately 200 mL of sample into a 400 mL beaker. Mix the sample with the lab mixer (see 6.5) for 60 s \pm 10 s at 500 r/min \pm 100 r/min. If optional blending is not required, proceed to 10.3.

10.2.1 *Optional Blending*—Clean the container of the 1 L (1 qt), high-speed blender (see 6.9). Vigorously hand shake the sample container for 1 min. Place 500 mL of sample into the container, cover, and blend at maximum speed for 1 min. Because it is normal for considerable air to be entrained during this agitation, allow to stand in a temperature controlled environment of 24 °C \pm 3 °C until entrained bubbles have dispersed and the temperature of the oil has reached 24 °C \pm 3 °C. Within 3 h following the agitation, continue testing at 10.3.

10.2.2 In case of viscous oils, 3 h can be insufficient time to eliminate the entrained air. If a longer time is required, record the time as a note on the results.

10.3 Heat the sample for 30 min in a convection oven set at 49 °C \pm 3 °C.

10.4 Allow the sample to cool to room temperature (23 °C \pm 4 °C). The test shall be performed within 3 h of the heating step.

10.5 Fill the 1000 mL graduated cylinder to the 180 mL mark, visually estimating the level to be within 5 mL.