



Designation: C1090/C1090M – 15 C1090/C1090M – 23

## Standard Test Method for Measuring Changes in Height of Cylindrical Specimens of Hydraulic-Cement Grout<sup>1</sup>

This standard is issued under the fixed designation C1090/C1090M; the number immediately following the designation indicates the year of original adoption or, in the case of revision, the year of last revision. A number in parentheses indicates the year of last reappraisal. A superscript epsilon ( $\epsilon$ ) indicates an editorial change since the last revision or reappraisal.

### 1. Scope\*

1.1 This test method covers measurement of the changes in height of hydraulic-cement grout by the use of ~~75 by 150 mm~~ [3 by 6 in.] 75 mm by 150 mm [3 in. by 6 in.] cylinders, when the cylinders are protected so that the tendency to change in height does not include evaporation so as to cause drying, uptake of moisture, carbonation, or exposure to temperatures outside the range  $23 \pm 2.0^\circ\text{C}$  [ $73 \pm 3.5^\circ\text{F}$ ]  $23^\circ\text{C} \pm 2.0^\circ\text{C}$  [ $73^\circ\text{F} \pm 3.5^\circ\text{F}$ ] or, optionally, to another specified temperature controlled within  $\pm 2.0^\circ\text{C}$  [ $\pm 3.5^\circ\text{F}$ ],  $\pm 2.0^\circ\text{C}$  [ $\pm 3.5^\circ\text{F}$ ].

1.2 If desired, this test method can be adapted to studies of changes in height involving either schedules or environmental treatment different from the standard procedures prescribed by this test method.

1.3 The values stated in either SI units or inch-pound units are to be regarded separately as standard. The values stated in each system ~~may not be~~ not necessarily exact equivalents; therefore, to ensure conformance with the standard, each system shall be used independently of the other. Combining ~~other, and~~ values from the two systems ~~may result in non-conformance with the standard. Some values have only SI units because the inch-pound equivalents are not used in practice..~~ shall not be combined.

NOTE 1—Sieve size is identified by its standard designation in Specification E11. The alternative designation given in parentheses is for information only and does not represent a different standard sieve size.

1.4 The text of this standard references notes and footnotes that provide explanatory material. These notes and footnotes (excluding those in tables and figures) shall not be considered as requirements of this standard.

1.5 *This standard does not purport to address all of the safety concerns, if any, associated with its use. It is the responsibility of the user of this standard to establish appropriate ~~safety and health~~ safety, health, and environmental practices and determine the applicability of regulatory limitations prior to use. (Warning—Fresh hydraulic cementitious mixtures are caustic and may cause chemical burns to exposed skin and tissue upon prolonged exposure.<sup>2</sup>)*

1.6 *This international standard was developed in accordance with internationally recognized principles on standardization established in the Decision on Principles for the Development of International Standards, Guides and Recommendations issued by the World Trade Organization Technical Barriers to Trade (TBT) Committee.*

<sup>1</sup> This test method is under the jurisdiction of ASTM Committee C09 on Concrete and Concrete Aggregates and is the direct responsibility of Subcommittee C09.68 on Volume Change.

Current edition approved Dec. 15, 2015; June 15, 2023. Published March 2016; July 2023. Originally approved in 1988. Last previous edition approved in 2010 as C1090 – 10. DOI: 10.1520/C1090\_C1090M-15.15. DOI: 10.1520/C1090\_C1090M-23.

<sup>2</sup> See Section on Safety Precautions, Manual of Aggregate and Concrete Testing, Annual Book of ASTM Standards, Vol. 04.02.

\*A Summary of Changes section appears at the end of this standard

## 2. Referenced Documents

### 2.1 ASTM Standards:<sup>3</sup>

- C125 Terminology Relating to Concrete and Concrete Aggregates
- C172/C172M Practice for Sampling Freshly Mixed Concrete
- C219 Terminology Relating to Hydraulic and Other Inorganic Cements
- C305 Practice for Mechanical Mixing of Hydraulic Cement Pastes and Mortars of Plastic Consistency
- C511 Specification for Mixing Rooms, Moist Cabinets, Moist Rooms, and Water Storage Tanks Used in the Testing of Hydraulic Cements and Concretes
- C670 Practice for Preparing Precision and Bias Statements for Test Methods for Construction Materials
- C827/C827M Test Method for Change in Height at Early Ages of Cylindrical Specimens of Cementitious Mixtures
- C939/C939M Test Method for Flow of Grout for Preplaced-Aggregate Concrete (Flow Cone Method)
- E11 Specification for Woven Wire Test Sieve Cloth and Test Sieves

## 3. Terminology

### 3.1 Definitions:

3.1.1 For definitions of terms used in this test method, refer to Terminologies C125 and C219.

### 3.2 Definitions of Terms Specific to This Standard:

3.2.1 *change in height*—either an increase or decrease in the vertical dimension of a test specimen, provided the change has been caused by factors other than externally applied forces, changes in ambient temperature not conforming to the specified range, drying caused by evaporation, carbonation, or uptake of moisture.

## 4. Significance and Use

4.1 This test method is intended to provide a means of assessing the ability of a hydraulic-cement grout to retain a stable volume during the stipulated testing period of 28 days, provided that the tendency to change height does not include the effects of drying caused by evaporation, uptake of moisture, carbonation, or exposure to temperatures outside the range  $23.0 \pm 2.0^\circ\text{C}$  [ $73 \pm 3.5^\circ\text{F}$ ]  $23.0^\circ\text{C} \pm 2.0^\circ\text{C}$  [ $73^\circ\text{F} \pm 3.5^\circ\text{F}$ ] (Note 2). An exception is made when the options described in the section on test conditions are exercised.

NOTE 2—This test method does not measure the change in height before setting (see Test Method C827/C827M).

## 5. Apparatus

5.1 *Cylinder Molds*, steel cylindrical molds with dimensions as shown in Fig. 1 and Table 1, fitted with clamp assemblies for closing, fitted with a removable ~~6 mm~~ **6 mm** [~~¼ in.~~] in.] thick steel base plate that can be clamped in place with the cylinder molds, top edge machined to a narrow rim as shown in Fig. 1.

NOTE 3—Satisfactory molds can be made from lengths of steel tubing or pipe that is slit on one side parallel to the longitudinal axis and fitted with a means of closing the vertical slit as well as a means of attaching a base plate.

5.2 *Glass Plate*, approximately 100 mm [4 in.] square by ~~6 mm~~ **6 mm** [~~¼ in.~~] in.] thick, thinly coated on one surface with a silicone-base spray or other inert material such as mineral oil, and permitted to dry before use.

5.3 *Hold-Down Weight*, having a mass of 1.5 kg [3 lb]  $\pm$  1%.

5.4 *Micrometer Bridge*, designed to support and hold one cylinder in a level, firm position (Fig. 2) with dimensions as shown in Table 1, with steel rods, and a top made of noncorroding metal with 4 equally spaced holes from the center of the hold-down device, not more than 1 mm [ $\frac{3}{64}$  in.] larger than the diameter of the measuring shaft of the micrometer depth gage, and numbered 1 to 4.

<sup>3</sup> For referenced ASTM standards, visit the ASTM website, www.astm.org, or contact ASTM Customer Service at service@astm.org. For Annual Book of ASTM Standards volume information, refer to the standard's Document Summary page on the ASTM website.

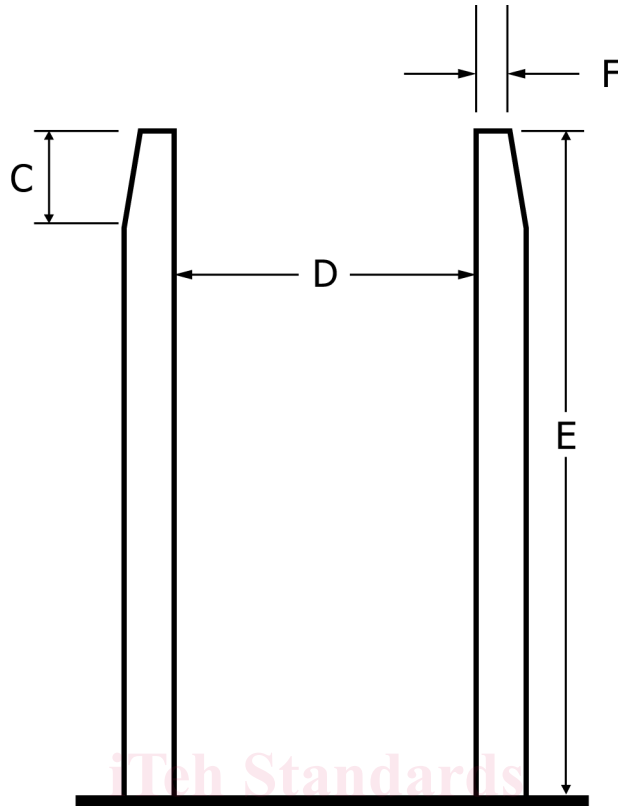

FIG. 1 Cylinder Mold with Machined (Tapered) Top Edge (see Table 1 for dimensions)

TABLE 1 Dimensions and Tolerances for Cylinder Mold (Fig. 1) and Micrometer Bridge (Fig. 2)

Dimensions	SI units	Inch-Pound Units	Tolerance
A	150 mm	6 in.	±2%
A	150 mm	6 in.	±2 %
B	75 mm	3 in.	±1%
B	75 mm	3 in.	±1 %
C	8 mm	5/16 in.	±20%
C	8 mm	5/16 in.	±20 %
D	75 mm	3 in.	±1%
D	75 mm	3 in.	±1 %
E	150 mm	6 in.	±2%
E	150 mm	6 in.	±2 %
F	1 mm	3/64 in.	±30%
F	1 mm	3/64 in.	±30 %
G	180 mm	7 in.	±2%
G	180 mm	7 in.	±2 %
H	10 mm	3/8 in.	±2%
H	10 mm	3/8 in.	±2 %
I	6 mm	1/4 in.	±2%
I	6 mm	1/4 in.	±2 %
J	185 mm	7 1/4 in.	±2%
J	185 mm	7 1/4 in.	±2 %
K	30 mm	1 1/4 in.	±20%
K	30 mm	1 1/4 in.	±20 %
L	50 mm	2 in.	±25%
L	50 mm	2 in.	±25 %

5.5 *Micrometer Depth Gage*, having a range from 25 to 50 mm [1.0 to 2.0 in.] 25 mm to 50 mm [1.0 in. to 2.0 in.] graduated in units not larger than 0.01 mm [0.001 in.]. The diameter of the shaft of the depth micrometer shall be 3.0 ± 0.4 mm [3.0 mm ± 0.4 mm [1/8 in. ± 1/64 in.], in.].

5.6 *Outside Micrometer Caliper*, used to measure the thickness of the plate, with a capacity of at least 12 mm [1/2 in.] and graduated in units not larger than 0.01 mm [0.001 in.] having throat depth of at least 50 mm [2.0 in.].

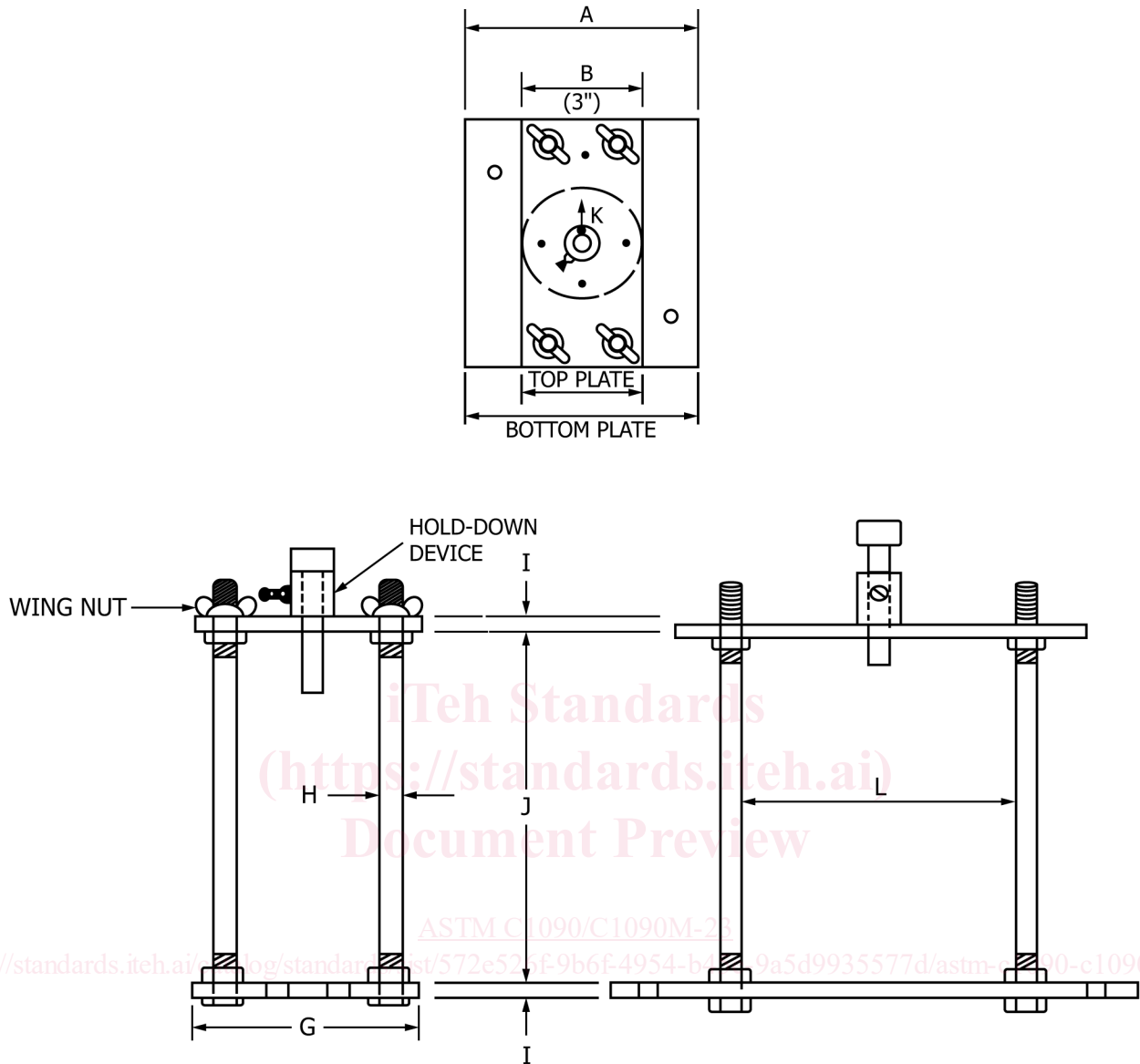

FIG. 2 Dimensions of Micrometer Bridge (see Table 1 for numerical values)

5.7 *Tamping Rod*, a straight steel rod with at least the tamping end rounded to a hemispherical tip of the same diameter as the rod, 10 mm [ $\frac{3}{8}$  in.] in diameter and at least 250 mm [10 in.] long.

5.8 *Mechanical Mixer*, as described in Practice C305.

NOTE 4—This mixer has clearances between paddle and bowl that are suitable only for mortars made with fine aggregates that are finer than the 850- $\mu\text{m}$  850  $\mu\text{m}$  (No. 20) sieve. Mortars made with aggregates containing particles coarser than the 850- $\mu\text{m}$  850  $\mu\text{m}$  (No. 20) sieve may require special clearance or a different type of paddle to permit the mixer to operate freely and avoid damage to the paddle and bowl.

## 6. Preparation of Sample

6.1 Take a sample of the freshly mixed grout to be tested either in accordance with Practice C172/C172M or prepared in sufficient quantity to permit molding at least one test specimen for height-change measurements and such additional tests as may be required or specified.



6.2 If the grout to be tested is blended from individual components, mix in accordance with Practice C305 (Note 5). If the grout is made using a packaged product, proceed as follows, unless otherwise recommended by the manufacturer.

6.2.1 Use ~~3000 to 3500 g [6 to 8 lb]~~ 3000 g to 3500 g [6 lb to 8 lb] of dry material as required and the proportionate amount of water required for the test. Record amounts used.

6.2.2 Place mixing water in mixing bowl.

6.2.3 Add dry material during the first ~~30-s~~ 30 s period while mixing at slow speed, ~~140~~ 140 rev/min ± 5-5 rev/min/min.

6.2.4 Continue mixing for 3 min, stopping the mixer for not over 15 s after 1 min to scrape down into the batch any grout that may have collected on the side of the bowl.

NOTE 5—If the grout contains fine aggregate, the mixing procedure for mortar is applicable; if it does not, that for paste is applicable.

6.3 Cast the specimen and lock the glass plate, micrometer bridge, top plate, plunger, and weight into position within ~~4-min~~ 4 min after completion of mixing. Complete the initial measurements within 3 min after completion of these operations.

6.4 If it is required or desired to cast the specimen after a longer holding period, continue mixing of either the whole or remaining portion, as appropriate, at slow speed for the specified time and the sample cast, apparatus locked, and take initial measurements within 3 min after completion of these operations.

## 7. Preparation of Apparatus

7.1 Coat the exterior seams of the cylinder mold and the exterior joint between the mold and the base plate with melted paraffin wax. Coat the interior of the cylinder mold and base plate lightly with mineral oil (Note 6). Attach the mold to the micrometer bridge.

NOTE 6—The exterior of the mold and the base plate may be coated with paraffin wax to facilitate cleanup after completion of the test.

## 8. Conditioning

8.1 Keep the air temperature at ~~23 ± 2°C [73 ± 3.5°F]~~, 23 °C ± 2 °C [73 °F ± 3.5 °F], and a relative humidity of not less than ~~50%~~ 50 %. Store the test specimen at a temperature of ~~23 ± 2°C [73 ± 3.5°F]~~, 23 °C ± 2 °C [73 °F ± 3.5 °F] for the duration of the test, unless otherwise specified. When it is desired to test the height change of material that is permitted to be used in the field at temperatures either below or above ~~23 ± 2°C [73 ± 3.5°F]~~, 23 °C ± 2 °C [73 °F ± 3.5 °F], use such other temperatures controlled to ~~±2°C (±3.5°F)~~, ±2 °C (±3.5 °F) throughout instead of ~~23 ± 2°C [73 ± 3.5°F]~~, 23 °C ± 2 °C [73 °F ± 3.5 °F]. Record the temperature of the mixing water, other materials, and of the mixture immediately after mixing is completed. Store the height-change apparatus in air at the desired test storage temperature within ~~±2°C [±3.5°F]~~, ±2 °C [±3.5 °F] before casting the specimen.

8.2 Protect the test specimen from loss of moisture, absorption of moisture, or reaction with carbon dioxide for the duration of the test. Store the specimen in the moist room or in laboratory air described in 8.2.2. Under either condition, the specimen shall remain protected at all times during the test for 28 days except during removal of the glass plate and the taking of measurements.

8.2.1 *Moist Room Storage*—Immediately after taking the initial measurements, cover the plunger and bridge apparatus with a plastic bag previously fitted and cut to a length that extends downward to the midpoint of the specimen mold to prevent water from dripping on the bridge, glass plate, or specimen. Then place the specimen without vibration in a moist room or moist cabinet meeting the requirements of Specification C511.

8.2.2 *Laboratory Air Storage*—Prior to casting the test specimen, place the entire apparatus in a prefitted plastic bag just large enough to be gathered and tied above the plunger and bridge. Roll down or collapse the bag so as not to interfere with the casting operation. Immediately after taking the initial measurement, place a damp, but not dripping, towel around the outside of the lower portion of the four posts supporting the bridge, inside the plastic bag. The towel shall extend upward, but not to more than half the height of the cylinder. Gather and tie the plastic bag just above the plunger and bridge.