



Standard Specification for Berths, Marine¹

This standard is issued under the fixed designation F1244; the number immediately following the designation indicates the year of original adoption or, in the case of revision, the year of last revision. A number in parentheses indicates the year of last reapproval. A superscript epsilon (ϵ) indicates an editorial change since the last revision or reapproval.

1. Scope

1.1 This specification covers the construction of marine berths for officers, crew, and passengers.

1.2 The values stated in inch-pound units are to be regarded as standard. The values given in parentheses are mathematical conversions to SI units that are provided for information only and are not considered standard.

1.3 *This international standard was developed in accordance with internationally recognized principles on standardization established in the Decision on Principles for the Development of International Standards, Guides and Recommendations issued by the World Trade Organization Technical Barriers to Trade (TBT) Committee.*

2. Referenced Documents

2.1 *ASTM Standards:*²

[A512 Specification for Cold-Drawn Butt Weld Carbon Steel Mechanical Tubing](#)

[A1008/A1008M Specification for Steel, Sheet, Cold-Rolled, Carbon, Structural, High-Strength Low-Alloy, High-Strength Low-Alloy with Improved Formability, Required Hardness, Solution Hardened, and Bake Hardenable](#)

[F825 Specification for Drawers, Furniture, Marine, Steel](#)

[F1085 Specification for Mattress and Box Springs for Use in Berths in Marine Vessels](#)

2.2 *AISC Manual:*³

[AISC Wire and Sheet Metal Gages—Equivalent Thicknesses in Decimals of an Inch, U.S. Standard Gage for Uncoated, Hot and Cold Rolled Sheets](#)

¹ This specification is under the jurisdiction of ASTM Committee F25 on Ships and Marine Technology and is the direct responsibility of Subcommittee F25.03 on Outfitting and Deck Machinery.

Current edition approved July 1, 2023. Published July 2023. Originally approved 1989. Last previous edition approved in 2018 as F1244 – 08 (2018). DOI: 10.1520/F1244-08R23.

² For referenced ASTM standards, visit the ASTM website, www.astm.org, or contact ASTM Customer Service at service@astm.org. For *Annual Book of ASTM Standards* volume information, refer to the standard's Document Summary page on the ASTM website.

³ Available from American Institute of Steel Construction (AISC), 130 E. Randolph St., Suite 2000, Chicago, IL 60601-6219, <http://www.aisc.org>.

3. Terminology

3.1 *Definitions of Terms Specific to This Standard:*

3.1.1 *base*—the structure on which the drawer and pan sections are supported and which serves to tie the berth to the deck.

3.1.2 *berth*—an item of fixed or built-in furniture for sleeping, with a base and drawer section below the mattress and box spring pan.

3.1.3 *berth side rail*—the berth side that runs from head to foot of berth.

3.1.4 *box spring*—the resilient box-type support for the mattress covered by fabric.

3.1.5 *drawer section*—the section of the berth below the pan section normally designed to contain drawers for stowage of life preservers and other items.

3.1.6 *hand*—the berth may be right hand, left hand, or finished both sides for use in the middle of the room. Right hand is defined as follows: the berth is right hand if the head of the berth is on the right hand end when the berth is viewed from the front. Left hand is opposite. See [Fig. 1](#) and [Fig. 2](#) and [Table 1](#) and [Table 2](#) for elevations of left-handed berths. A berth finished on both sides is not shown, but it is one that is accessible from either side, has the head of the berth against a bulkhead, and is not handed.

3.1.7 *lee rail*—a guard to inhibit a person from rolling out of bed because of ship motion. In this specification, the lee rail is a raised pine railing.

3.1.8 *mattress*—a fabric-covered, box-type unit containing springs and cushioning material that supports the sleeping surface.

3.1.9 *pan section*—the section of the berth designed to support the mattress and box spring.

4. Classification

4.1 *Type I*—A single berth with pipe, side lee rail with a box spring and mattress pan having inside measurements of 54 in. (1372 mm) wide by 80 ½ in. (2045 mm) long. (See [Fig. 1](#), [Table 1](#), and [Note 8](#) and [Note 11](#) of [Fig. 1](#).)

4.1.1 *Type IA*—Berths conforming generally to the Type I specifications but having special requirements as indicated in the ordering information.

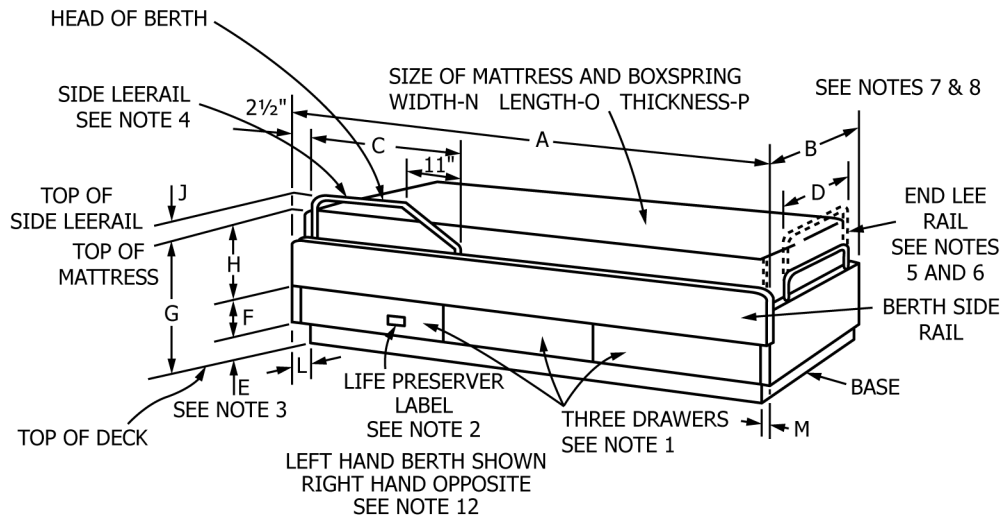

NOTE 1—For a description of the drawers, see Specification F825. The minimum stowage capacity of each drawer shall be 1.35 ft³ (0.038 m³) (drawer pulls not shown).

NOTE 2—The location of life preserver stowage shall be indicated on the front face of one drawer. See 6.10 for description.

NOTE 3—The minimum value for Dimension “E” (toe space height) shall be 3/4 in. (83 mm).

NOTE 4—Berth Types I, II, or III, with pipe rail detail, will be supplied as shown on Fig. 1. For description of pipe rail, see 6.12.

NOTE 5—End lee rail for bottom berths that are to be installed athwartship shall be furnished extending above the mattress, to restrain occupant in heavy seas. (See 5.1.6.2).

NOTE 6—See 6.12 for a description of the pipe lee rail.

NOTE 7—For a description of the mattress and box springs, see Specification F1085.

NOTE 8—The mattress and box spring are ordered 1 in. (25.4 mm) smaller in width and length than the inside dimensions of the berth pan.

NOTE 9—Dimensions G, H, I, and J are shown as nominal dimensions, without tolerances. Their real value depends upon the tolerance of the thickness of the mattress and the box spring. The commercial tolerance on these thicknesses is ±1/2 in. (12 mm).

NOTE 10—Where ceiling heights are low, overhead clearance, Dimension I, should be equalized between upper and lower berths. Minimum clearance is 20 in. (508 mm).

NOTE 11—Fig. 1 and Fig. 2 depict the basic berth Types I, II, and III covered by these specifications. If special architectural requirements are needed to match other furniture in the same area, they shall be defined in the ordering specifications and berths will be identified as Types IA, IIA, and IIIA.

NOTE 12—For hand of berths see 3.1.6.

FIG. 1 Type I (53-in. (1345-mm) wide mattress) and Type II (38-in. (965-mm) wide mattress) Berths With Pipe, Side Lee Rail

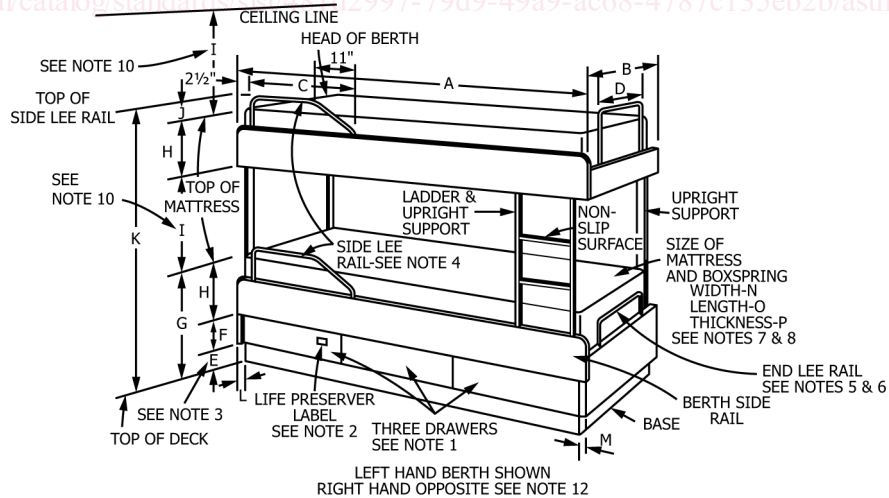

NOTE 1—See Notes 1-12 under Fig. 1.

FIG. 2 Type III (38-in. (965-mm) Wide Mattress) Berths With Side Lee Rail

4.2 Type II—A single berth with pipe, side lee rail with a box spring and mattress pan having inside measurements of

39 in. (991 mm) wide by 80 1/2 in. (2045 mm) long. (See Fig. 1, Table 1, and Note 8 and Note 11 of Fig. 1).

TABLE 1 Dimensions of Type I and Type II Berths

Designation	in.		mm		Note (See Fig. 1)	
	Dimension	Tolerance to + or –	Dimension	Tolerance to + or –		
Length	A	85	max	2159	max	
Type I width	B	59	max	1499	max	
Type II width	B	44	max	1118	max	
Lee rail length	C	30	min	762	min	
Lee rail length	D	24	min	610	min	
Toe space height	E	4¾	...	121	...	See Note 3.
Drawer section height	F	6½	⅙	165	3	
Deck to mattress	G	24¾	...	629	...	See Note 9.
Box spring plus mattress height	H	13½	...	343	...	See Note 9.
Lee rail height	J	6½	...	165	...	See Note 9.
Toe space, front	L	1½	min	38	min	
Toe space, end	M	¼	min	6	min	
Type I mattress or box spring width	N	53	...	1346	...	See Note 7, Note 8, and Note 9.
Type II mattress or box spring width	N	38	...	965	...	See Note 7, Note 8, and Note 9.
Mattress or box spring length	O	79½	...	2019	...	See Note 7, Note 8, and Note 9.
Mattress or box spring thickness	P	7	...	178	...	

TABLE 2 Dimensions of Type III Berths

Designation	in.		mm		Note (See Fig. 1)	
	Dimension	Tolerance to + or –	Dimension	Tolerance to + or –		
Length	A	85	max	2159	max	
Width	B	44	max	1118	max	
Lee rail length	C	30	min	762	min	
Lee rail length	D	24	min	610	min	
Toe space height	E	4¾	...	121	...	See Note 3.
Drawer section height	F	6½	⅙	165	3	
Deck to mattress	G	24¾	...	629	...	See Note 9.
Box spring plus mattress height	H	13½	...	343	...	See Note 9.
Overhead clearance	I	23¾	...	619	...	See Note 9 and Note 10.
Lee rail height	J	6½	...	165	...	See Note 9.
Overall height	K	68⅙	max	1730	max	
Toe space, front	L	1½	min	38	min	
Toe space, end	M	¼	min	6	min	
Type II mattress or box spring width	N	38	...	965	...	See Note 7, Note 8, and Note 9.
Mattress or box spring length	O	79½	...	2019	...	See Note 7, Note 8, and Note 9.
Mattress or box spring thickness	P	7	...	178	...	See Note 7, Note 8, and Note 9.

4.2.1 *Type IIA*—Berths conforming generally to the Type II specifications but having special requirements as indicated in the ordering information.

4.3 *Type III*—A two-high berth with pipe, side lee rail, the same as Type II, but fitted with an additional pan and uprights to form an upper berth. (See Fig. 2, Table 2, and Note 8, Note 10, and Note 11 of Fig. 1).

4.3.1 *Type IIIA*—Berths conforming generally to the Type III specifications but having special requirements as indicated in the ordering information.

5. Ordering Information

5.1 Orders for items purchased under this specification shall include the following:

5.1.1 Type of berth.

5.1.1.1 Type I, IA; II, IIA; or III, IIIA.

5.1.1.2 *Hand*—Right, left, or finished both sides.

5.1.2 *Quantity*—The quantity of right hand, left hand, or finished both sides for each type.

5.1.3 *Mattress and Box Spring*—Shall be furnished in accordance with Specification F1085.

5.1.4 *Paint*:

5.1.4.1 *Color*—The purchaser shall pick from manufacturer's samples or submit a sample chip of the color desired.

5.1.4.2 The manufacturer's standard baked enamel will be furnished unless otherwise required and specified by the purchaser.

5.1.5 *Weights*—If the total weight of the berth assembly is required, it shall be requested by the purchaser.

5.1.6 *Options*:

5.1.6.1 If a special architectural appearance or finish is required for these berths to match other furniture in the same space, it shall be defined in the ordering documents.

5.1.6.2 The pipe lee rail at the foot of all berths shall be furnished extending above the mattress, to restrain occupants in heavy sea.

5.1.6.3 Normally, on berths installed in a corner, the head of the berth is installed against one of the bulkheads. On some