



Standard Specification for Cleats, Welded Horn Type¹

This standard is issued under the fixed designation F1074; the number immediately following the designation indicates the year of original adoption or, in the case of revision, the year of last revision. A number in parentheses indicates the year of last reapproval. A superscript epsilon (ϵ) indicates an editorial change since the last revision or reapproval.

1. Scope

1.1 This specification covers hollow cleats and pads for marine use.

1.2 The cleats shall be used where securing of boat handling lines are required onboard commercial and navy boats and crafts.

1.3 The values stated in inch-pound units are to be regarded as standard. The values given in parentheses are mathematical conversions to SI units that are provided for information only and are not considered standard.

1.4 *This international standard was developed in accordance with internationally recognized principles on standardization established in the Decision on Principles for the Development of International Standards, Guides and Recommendations issued by the World Trade Organization Technical Barriers to Trade (TBT) Committee.*

2. Referenced Documents

2.1 *ASTM Standards:*²

A36/A36M Specification for Carbon Structural Steel

A370 Test Methods and Definitions for Mechanical Testing of Steel Products

A385 Practice for Providing High-Quality Zinc Coatings (Hot-Dip)

3. Ordering Information

3.1 Orders for material under this specification shall include the following:

¹ This specification is under the jurisdiction of ASTM Committee F25 on Ships and Marine Technology and is the direct responsibility of Subcommittee F25.03 on Outfitting and Deck Machinery.

Current edition approved July 1, 2023. Published July 2023. Originally approved in 1987. Last previous edition approved in 2018 as F1074 – 87 (2018). DOI: 10.1520/F1074-87R23.

² For referenced ASTM standards, visit the ASTM website, www.astm.org, or contact ASTM Customer Service at service@astm.org. For *Annual Book of ASTM Standards* volume information, refer to the standard's Document Summary page on the ASTM website.

3.1.1 Title, number, and date of this specification,

3.1.2 Quantity,

3.1.3 Size of cleats, and

3.1.4 Packaging, packing, or marking requirements.

4. Materials and Manufacture

4.1 *Material:*

4.1.1 The horn cleats shall be of galvanized steel, grade 1023W, in accordance with Practice A385.

4.1.2 The base plate shall be of steel, (carbon 0.35 maximum), in accordance with Specification A36/A36M.

4.1.3 All chafing surfaces shall have a 125 μ finish.

4.2 *Manufacture*—The cleats' horns shall be of cast steel, round in shape, and free of burrs or sharp edges. The horns shall be welded to a base plate as shown in Fig. 1 (see Table 1). The weld is to be ground smooth to prevent chafing of ropes. The base plate shall be oval shaped with smooth rounded edges. The dimensions shall be in accordance with Table 1.

5. Packaging

5.1 The packing shall afford protection against deterioration and physical damage during shipment from the manufacturer to the using activity for immediate use.

6. Product Marking

6.1 Containers shall be stenciled with the ASTM standard designation, in black paint with approximately 1 in. (25.4 mm) high letters and numbers with the following information:

6.1.1 Address,

6.1.2 purchase order number, and

6.1.3 Manufacturer's name.

7. Keywords

7.1 base plates; boat handling lines; cleats; hollow cleats; horn cleats; marine; marine cleats; ship; welded cleats

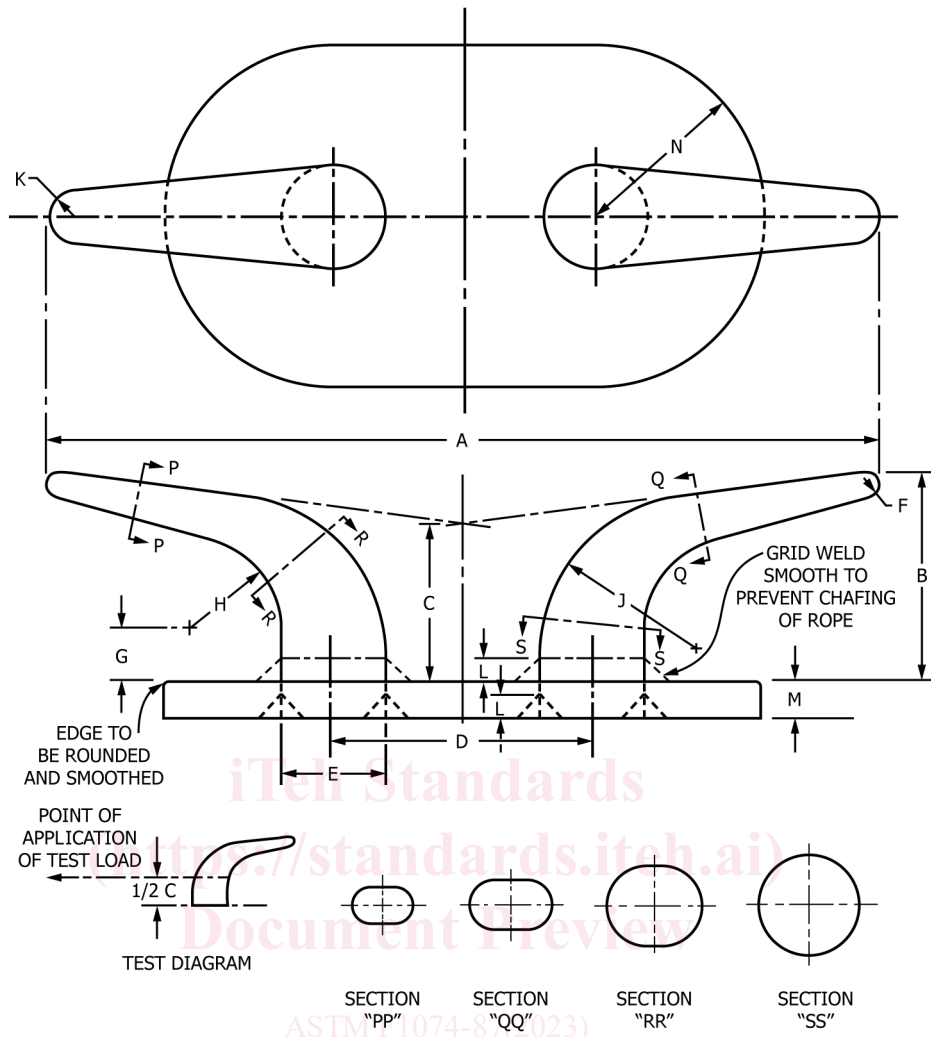

SECTION "PP" SECTION "QQ" SECTION "RR" SECTION "SS"

NOTE 1—See Table 1 for dimensions.

FIG. 1 Welded Horn Type Cleat (16 in.)