



Designation: E741 – 23

# Standard Test Method for Determining Air Change in a Single Zone by Means of a Tracer Gas Dilution<sup>1</sup>

This standard is issued under the fixed designation E741; the number immediately following the designation indicates the year of original adoption or, in the case of revision, the year of last revision. A number in parentheses indicates the year of last reapproval. A superscript epsilon ( $\epsilon$ ) indicates an editorial change since the last revision or reapproval.

## 1. Scope

1.1 This test method covers techniques using tracer gas dilution for determining a single zone's air change with the outdoors, as induced by weather conditions and by mechanical ventilation. These techniques are: (1) concentration decay, (2) constant injection, and (3) constant concentration.

1.2 This test method is restricted to a single tracer gas.

1.3 The associated data analysis assumes that one can characterize the tracer gas concentration within the zone with a single value. The zone shall be a building, vehicle, test cell, or any conforming enclosure.

1.4 Use of this test method requires a knowledge of the principles of gas analysis and instrumentation. Correct use of the formulas presented here requires consistent use of units, especially those of time.

1.5 Determination of the contribution to air change by individual components of the zone enclosure is beyond the scope of this test method.

1.6 The results from this test method pertain only to those conditions of weather and zonal operation that prevailed during the measurement. The use of the results from this test to predict air change under other conditions is beyond the scope of this test method.

1.7 The text of this test method references notes and footnotes which provide explanatory material. These notes and footnotes (excluding those in tables and figures) shall not be considered requirements of this test method.

1.8 *This standard does not purport to address all of the safety concerns, if any, associated with its use. It is the responsibility of the user of this standard to establish appropriate safety, health, and environmental practices and determine the applicability of regulatory limitations prior to use.*

<sup>1</sup> This test method is under the jurisdiction of ASTM Committee E06 on Performance of Buildings and is the direct responsibility of Subcommittee E06.41 on Air Leakage and Ventilation Performance.

Current edition approved July 1, 2023. Published July 2023. Originally approved in 1980. Last previous edition approved in 2017 as E741 – 11 (2017). DOI: 10.1520/E0741-23.

1.9 *This international standard was developed in accordance with internationally recognized principles on standardization established in the Decision on Principles for the Development of International Standards, Guides and Recommendations issued by the World Trade Organization Technical Barriers to Trade (TBT) Committee.*

## 2. Referenced Documents

### 2.1 ASTM Standards:<sup>2</sup>

D4480 Test Method for Measuring Surface Wind by Means of Wind Vanes and Rotating Anemometers (Withdrawn 1999)<sup>3</sup>

E260 Practice for Packed Column Gas Chromatography

E631 Terminology of Building Constructions

E779 Test Method for Determining Air Leakage Rate by Fan Pressurization

E1186 Practices for Air Leakage Site Detection in Building Envelopes and Air Barrier Systems

### 2.2 ASHRAE Documents:<sup>4</sup>

ASHRAE Handbook of Fundamentals Chapter 23

ASHRAE Standard 62 Ventilation And Acceptable Indoor Air Quality

## 3. Terminology

### 3.1 Definitions:

3.1.1 For definitions of general terms related to building construction used in this test method, refer to Terminology E631.

### 3.2 Definitions of Terms Specific to This Standard:

3.2.1 *air change flow,  $Q, n$* —the total volume of air passing through the zone to and from the outdoors per unit time ( $\text{m}^3/\text{s}$ ,  $\text{m}^3/\text{h}$ ,  $\text{ft}^3/\text{h}$ ).

<sup>2</sup> For referenced ASTM standards, visit the ASTM website, [www.astm.org](http://www.astm.org), or contact ASTM Customer Service at [service@astm.org](mailto:service@astm.org). For *Annual Book of ASTM Standards* volume information, refer to the standard's Document Summary page on the ASTM website.

<sup>3</sup> The last approved version of this historical standard is referenced on [www.astm.org](http://www.astm.org).

<sup>4</sup> Available from American Society of Heating, Refrigerating, and Air-Conditioning Engineers, Inc. (ASHRAE), 1791 Tullie Circle, NE, Atlanta, GA 30329, <http://www.ashrae.org>.

3.2.2 *air change rate, A, n*—the ratio of the total volume of air passing through the zone to and from the outdoors per unit of time to the volume of the zone (1/s, 1/h).<sup>5</sup>

3.2.3 *envelope, n*—the system of barriers between a conditioned building zone and the outdoors.

3.2.3.1 *Discussion*—This includes exterior doors, windows, roofs, walls, floors and ductwork. It excludes interior partitions, ducts, and so forth, that separate conditioned zones.

3.2.4 *single zone, n*—a space or set of spaces wherein the concentration of a tracer gas is maintained uniformly throughout and that only exchanges air with the outside.

3.2.4.1 *Discussion*—Multizone buildings are difficult to treat as single zones and meet the uniformity of tracer gas concentration required in this test method. Single zones within multizone buildings are difficult to isolate such that they exchange air only with the outside and not to other zones within the building via ventilation ducts, electrical conduits, elevator shafts, stairs, and other pathways.

3.2.5 *tracer gas, n*—a gas that is mixed with air and measured in very small concentrations in order to study air movement.

3.2.6 *tracer gas analyzer, n*—a device used to measure the concentration of tracer gas in an air sample.

3.2.7 *tracer gas concentration, C, n*—the ratio of the quantity of tracer gas in air to the quantity of that air (moles/mole or m<sup>3</sup>/m<sup>3</sup>).

### 3.3 Symbols:

#### 3.3.1 Variables:

<i>A</i>	= air change rate (1/s, 1/h).
<i>C</i>	= concentration (dimensionless).
<i>CONF</i>	= confidence limit value (units of the variable measured).
<i>d</i>	= desired precision (dimensionless).
<i>ESE</i>	= estimated standard error.
<i>i</i>	= location number.
<i>k</i>	= constant.
<i>n</i>	= number of data points.
<i>N</i>	= number of sampling locations in the zone.
<i>Q</i>	= flow (m <sup>3</sup> /s, m <sup>3</sup> /h, ft <sup>3</sup> /h).
<i>s</i>	= sample standard deviation (units of the variable estimated).
<i>t</i>	= a specific time (s, h).
<i>T</i>	= a period of time (s, h).
<i>V</i>	= volume (m <sup>3</sup> , ft <sup>3</sup> ).
<i>α</i>	= probability (dimensionless).
<i>ε</i>	= error (units of the variable estimated).
<i>v</i>	= coefficient of variation (dimensionless).

#### 3.3.2 Superscripts:

'	= value at the end of the test.
–	= mean value.

#### 3.3.3 Subscripts:

<i>A</i>	= pertaining to air change rate.
<i>avg</i>	= average.
<i>bias</i>	= pertaining to bias.
<i>C</i>	= pertaining to concentration.
<i>est</i>	= estimated.
<i>GA</i>	= pertaining to the gas analyzer.
<i>i</i>	= pertaining to time or location.
<i>inj</i>	= pertaining to the injection period.
<i>lower</i>	= lower limit.
<i>meas</i>	= pertaining to the measurement.
<i>mix</i>	= pertaining to the mixing period.
<i>precis</i>	= pertaining to precision.
<i>rep</i>	= pertaining to replicates.
<i>sample</i>	= pertaining to a discrete tracer gas or air sample.
<i>target</i>	= pertaining to the desired level of tracer gas.
<i>test</i>	= pertaining to the test period.
<i>tracer</i>	= pertaining to the tracer gas.
<i>twt</i>	= weighted according to tracer gas flow.
<i>upper</i>	= upper limit.
<i>vol</i>	= pertaining to the volume of the zone.
<i>zone</i>	= pertaining to the zone under study.
<i>1</i>	= first occurrence under discussion.
<i>2</i>	= last occurrence under discussion.

#### 3.3.4 Other Notations:

$\Delta t$	= time interval between periodic samples.
$f(t)$	= function of time.
$f(t, i)$	= function of time, <i>t</i> , and location, <i>i</i> .
$t(n, 1-\alpha)$	= <i>t</i> -distribution value for <i>n</i> degrees of freedom and a two-sided probability of $\alpha$ .

## 4. Summary of Test Method

4.1 This test method uses the measurement of tracer gas dilution to determine air change within a building or other enclosure that is characterized as a single zone. The measurement of the concentration, and sometimes the volume rate of the tracer gas that is injected into the zone, allows calculation of the volume rate of outgoing air from the zone. From this, one can infer the volume rate of incoming air. Three techniques are presented: (1) concentration decay, (2) constant injection, and (3) constant concentration. Each technique employs specific tracer gas injection and sampling strategies. Other techniques exist but are beyond the scope of this test method. **Table 1** summarizes the three techniques.

4.2 *Choice of Technique*—In choosing a technique for measuring air change, consider the quantity to be measured, the comparative capabilities of the techniques, and the complexity of the required equipment.

4.2.1 *Air Change Quantity to Be Measured*—Choose between direct measurement of air change rate or air change flow. Conversions between rate and flow and vice versa are subject to the precision and bias of the measurement of the zone volume. To obtain air change rate directly, use the tracer gas decay technique. To obtain air change flow, use the constant injection or constant concentration techniques.

## 5. Significance and Use

5.1 *Effects of Air Change*—Air change often accounts for a significant portion of the heating or air-conditioning load of a

<sup>5</sup> A common way of expressing air change rate units is ACH = air changes per hour = 1/h.

**TABLE 1 Summary of Air Change Measurement Techniques**

NOTE 1—*Speed of Measurement*—A one-time measurement of air change is most quickly acquired with the concentration decay technique and least quickly with the constant concentration technique.

NOTE 2—*Time-Varying Air Change*—The constant concentration and constant injection techniques may be useful for measuring air change rates that vary with time.

NOTE 3—*Complexity of Zone Geometry*—Whereas all the techniques require uniform tracer gas concentration, the constant concentration technique may be useful to achieve this in a zone with complex geometry.

NOTE 4—*Equipment Complexity*—The complexity of the required equipment is lowest for the tracer gas decay technique and highest for the constant concentration technique.

Tech- nique	Type of Air Change Measurement	Steady-State Assumption Required?	Volume Control of Tracer Gas	Concentration Measurement Relative To
<b>Concentration Decay—Section 8</b>				
Average	Rate	No	Approximate initial target	Other samples
Regression	Rate	Yes	Approximate initial target	Other samples
<b>Constant Injection—Section 9</b>				
Average	Flow	No	Flow rate to within 2 %	Absolute standard
<b>Constant Concentration—Section 10</b>				
	Flow	No	Mean concentration within 2 % of target	Absolute standard

building. It also affects the moisture and contaminant balances in the building. Moisture-laden air passing through the building envelope can permit condensation and cause material degradation. An appropriate level of ventilation is required in all buildings; one should consult ASHRAE Standard 62 to determine the ventilation requirements of a building.

5.2 *Prediction of Air Change*—Air change depends on the size and distribution of air leakage sites, pressure differences induced by wind and temperature, mechanical system operation, and occupant behavior. Air change may be calculated from this information, however, many of the needed parameters are difficult to determine. Tracer gas testing permits direct measurement of air change.

5.3 *Utility of Measurement*—Measurements of air change provide useful information about ventilation and air leakage. Measurements in buildings with the ventilation system closed are used to determine whether natural air leakage rates are higher than specified. Measurements with the ventilation system in operation are used to determine whether the air change meets or exceeds requirements.

5.4 *Known Conditions*—Knowledge of the factors that affect air change makes measurement more meaningful. Relating building response to wind and temperature requires repetition of the test under varying meteorological conditions. Relating building response to the ventilation system or to occupant behavior requires controlled variation of these factors.

5.5 *Applicability of Results*—The values for air change obtained by the techniques used in this test method apply to the specific conditions prevailing at the time of the measurement. Air change values for the same building will differ if the prevailing wind and temperature conditions have changed, if

the operation of the building is different, or if the envelope changes between measurements because of construction or deterioration. To determine air leakage sites, follow Practices E1186.

5.6 *Fan Pressurization*—A related technique (Test Method E779) uses a fan to pressurize the building envelope. Measurements of corresponding air flows and pressure differences across the envelope characterize envelope airtightness as either the air leakage rate under specified induced pressure differences or the equivalent leakage area of the envelope. These factors permit modeling natural air change due to wind and temperature differences. However, direct measurement of natural air change is not possible with Test Method E779. Test Method E779 permits comparison of different buildings, isolation of leakage sites, and evaluation of retrofit measures.

## 6. Apparatus

6.1 The apparatus includes means for distributing the tracer gas, means for obtaining air samples, a gas analyzer to measure tracer gas concentration in the air samples, and other measurement devices.

6.2 *Tracer Gas*—See Appendix X1 for information on tracer gases and equipment used to measure their concentrations. Appendix X1 also contains tracer gas target concentration levels and safety information.

6.2.1 *Tracer Gas Concentration Standard*—A known concentration of tracer gas in air.

6.3 *Tracer Gas Injection and Distribution Apparatus*—There are several means for releasing the appropriate volume of tracer gas and distributing it in the zone.

6.3.1 *Tracer Gas Metering and Injection Devices*—These include (1) a graduated syringe or other container of known volume with a means for controlled release of its contents and (2) a compressed tracer gas supply with a critical orifice, a critical orifice metering valve, an electronic mass flow controller, or other tracer gas flow rate measurement and control device.

6.3.2 *Tracer Gas Distribution Devices*—These include (1) fans that permit good mixing of tracer gases injected manually within the zone (oscillating or hassock fans, or, ducted forced air systems can serve this purpose), (2) tubing networks that dispense tracer gas via manifolds and automated valves and (3) pressure-operated valves that stop the flow from a tubing network when the tubing is not pressurized. (Note that leaks in tubing networks release tracer gas at unintended locations.)

6.4 *Tracer Gas Sampling Apparatuses*—Examples include containers for manual sampling and automatic samplers that employ containers or networks.

6.4.1 *Materials for Sampling Apparatuses*—Select and check materials used in tracer gas sampling systems carefully for their reactivity and absorption of the tracer gas in use. Depending on the tracer gas, desirable materials include glass, copper, and stainless steel. Metal foil is appropriate for flexible containers. Other acceptable materials include polypropylene, polyethylene, and nylon. Materials that absorb tracer gas degrade the accuracy of the measurement. Other materials release substances that interfere with tracer gas analyzer



accuracy. Depending on the tracer gas, materials to avoid include soft plastics, like vinyl and TFE-fluorocarbon.

**6.4.2 Manual Samplers**—These include syringes, flexible bottles, or air sample bags with a capacity of at least three times the minimum sample size of the gas analyzer used. These containers shall have an airtight seal to assure that the sample is not diluted or contaminated. Each container shall have a label that keys it to a record of the time and location that it was used. Do not reuse sample containers without first confirming that they are not contaminated with tracer gas.

**6.4.3 Automatic Samplers**—These apparatuses comprise either a sampling network or automated samplers.

**6.4.3.1 Sampling Networks**—These include (1) tubing, (2) a manifold or selection switch (the manifold receives, combines, and averages equal flows from individual legs of the network; the selection switch, often solenoid-driven, permits sampling of individual legs of the network), and (3) a pump that draws air samples through the network at a rate that minimizes delays between the time air samples leave the zone and the time they reach the gas analyzer.

**6.4.3.2 Automated Samplers**—These self-contained units, such as syringe samplers, are programmed to draw air samples at defined time intervals. Place such devices at different locations throughout the zone to be evaluated when required.

**6.5 Gas Analyzer**—This device shall be suited for the tracer gas used and the concentrations within the zone studied. It shall be properly calibrated and have a precision<sup>6</sup> of better than  $\pm 5\%$  at concentrations employed in the tracer gas study. See **Appendix X2** for calibration information.

**6.6 Ancillary Measurement Devices:**

**6.6.1 Portable Meteorological Station**—This records wind speed and direction and outdoor temperature. Meteorological data collected at a local weather station are acceptable.

**6.6.2 Temperature Measurement**—Use a thermometer or record the output of thermocouples, thermistors, resistance thermal devices (RTDs), and so forth.

**6.6.3 Timing Device**—This provides a common standard for all events relating to the measurement procedure, including gas injection times, sampling times, and meteorological driving forces. The timing device shall determine time differences between events within a 1 % uncertainty.

**6.7 Data Acquisition and Control System**—This equipment is optional for all but the constant concentration technique.

**6.7.1 Data Acquisition**—Appropriate interfaces provide temperature, wind speed, wind direction, and tracer gas concentration data to a computer or other machine-readable data storage unit.

**6.7.2 Control of Processes**—A computer uses current tracer gas concentration information to control metering and switching equipment to deliver tracer gas to the appropriate parts of the network. When a feedback process controls gas concentrations, based on gas concentration measurements, an algorithm that minimizes deviation from the target concentra-

tion is required. A digital optimal adaptive proportional control algorithm has been used effectively for constant concentration measurements (1).<sup>7</sup>

## 7. Hazards

**7.1 Safety** is the responsibility of the user of this test method. Tracer gases have safe maximum concentration limits due to health and, in some cases, explosiveness. **Table X1.1** presents, as a guide, the maximum allowable concentration in air for some tracer gases that have been used for air change measurements. The tracer gas supplier's material safety data sheet also provides information about health, fire, and explosion hazards.

**7.2 Health Limitations**—Use the current OSHA information on the permissible exposure limit (PEL) to determine the maximum safe concentration for the tracer gas chosen for the test. Use a concentration that is at most one tenth of the maximum safe concentration. Avoid using tracer gases for which no OSHA PEL exists.

**NOTE 1**—Special circumstances may cause one tenth of PEL to be too high a concentration. For example, the heat of a lit cigarette decomposes some tracer gases into potentially hazardous by-products when air is inhaled through the cigarette. In such cases, lower tracer gas concentrations are required.

**7.3 Explosive Limits**—If the tracer gas is explosive, the tracer gas concentration shall never exceed one tenth the lower explosive limit.

**7.4 Compressed Gas Equipment**—Observe the supplier's safety information and CGA (2) information on the transportation, use, and storage of compressed gas cylinders, regulators, and related equipment.

## 8. Procedure for the Concentration Decay Test Method

**8.1 Summary**—To determine average air change rate, one introduces a small volume of tracer gas uniformly into the zone, ensures a uniform concentration, and then measures tracer gas concentration at known times. One calculates the average air change rate for that period as the difference between the logarithms of the initial and final tracer gas concentrations divided by the time period. When required, one shall obtain additional air samples to test the hypothesis that the air change rate was constant during the test with an optional regression analysis of the logarithms of additional tracer gas concentration measurements. **Fig. 1** gives a simplified overview of this test method.

**8.2 Preparation:**

**8.2.1 Ancillary Measurements**—Refer to **11.1**.

**8.2.2 Zonal Operation**—Prepare the zone according to **11.2**.

**8.2.3 Tracer Gas Injection Volume**—Determine the volume of the tracer gas to be injected  $V_{tracer}$  according to the following steps:

**8.2.3.1** Estimate the volume of the zone  $V_{zone}$  in the same units as  $V_{tracer}$  will be measured (**15.3**),

<sup>6</sup> Precision refers to the standard error of the measurement.

<sup>7</sup> The boldface numbers in parentheses refer to the list of references at the end of this standard.

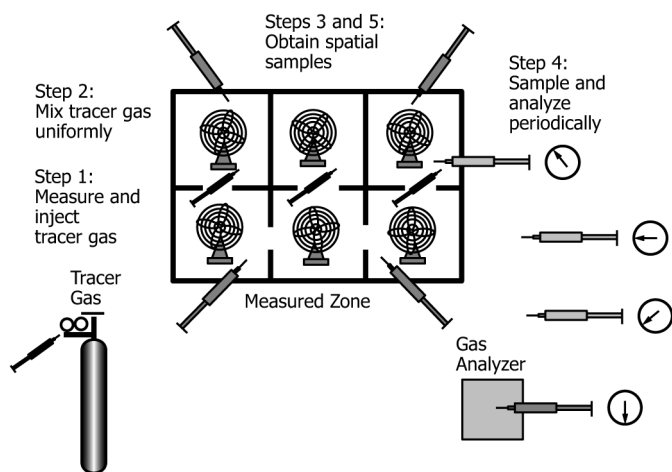

**FIG. 1 Simplified Summary of the Apparatus and Procedure for the Concentration Decay Method**

8.2.3.2 Determine the target tracer gas concentration  $C_{target}$  at the high end of the detection limits of the gas analyzer, and  
 8.2.3.3 Compute the following:

$$V_{tracer} = C_{target} \times V_{zone} \quad (1)$$

8.2.4 *Sampling*—Emplace the desired apparatus for sampling, according to one of the methods described in Section 13. Note that manual sampling, 13.1, or direct automated sampling, 13.2.2, are the most likely choices.

8.2.4.1 *Sampling Duration*—Table 2 illustrates *minimum* sampling durations based on a 10 % uncertainty at the 95 % confidence level in the determination of air change rate, a tracer gas concentration measurement precision error (14.1.3),  $v_{meas}$ , of 5 % of reading, and various air change rates. Refer to Eq A1.1 for the general case. Note that when using the regression method the minimum test duration is often less than the test duration values shown in Table 2. This decrease in test duration is primarily due to the inclusion of more than two data points in the determination of the best fit line as described in 8.5.3.2.

8.2.4.2 *Sampling Frequency*—For the optional regression method (8.5.3.2), there shall be a minimum of five points, approximately evenly distributed over the measurement period.

8.3 *Tracer Gas Injection*—Note that manual injection, 12.2, is the simplest acceptable technique of those available in Section 12. Record the time and volume of the injection. Distribute the tracer gas uniformly in the zone according to 12.4.3 in order to meet the uniformity of concentration criterion of 12.4.1.

**TABLE 2 Examples of Minimum Durations Between the Initial and Final Samples for the Above Assumptions**

Air Change Rate (1/h)	Minimum Duration of Test (h)
0.25	4
0.5	2
1	1
2	0.5
4	0.25

8.4 *Sampling*—First, perform spatial sampling to confirm uniformity of concentration, using 13.3. When the uniformity of concentration criterion 12.4.1 is confirmed, then sample as follows:

8.4.1 *All Conditions*—At a minimum, take a second set of spatial samplings (13.3) at the end of the sampling period, for the period  $T_{test}$ . Check for tracer gas sources in adjacent spaces, according to 13.4.3.

8.4.2 *Time Series for the Optional Regression Method*—Take representative samples at intervals, as determined in 8.2.4.2. A minimum of five such samples is required for the regression method (8.5.3.2).

8.5 *Analysis:*

8.5.1 *Analyze Tracer Gas Concentrations*—Analysis of tracer gas concentration takes place either on site concurrently with the sampling process, or off site, if the samples are stored in sealed, labeled containers. Analyze and record the tracer gas concentration of each sample, together with the sampling time and location, according to the procedures in Section 14. Eliminate any concentration data that are outside the 5 % precision range of the analyzer.

8.5.2 *Confirm Uniformity of Concentration*—Assess the concentrations of the spatial samplings for uniformity of concentration, according to 12.4.1. Confirm uniformity of tracer gas concentrations at the beginning and end of the sampling period (8.4.1). Estimate the measurement precision using 14.1.3.

8.5.3 *Calculate Air Change Rate*—Calculate air change rate by the averaged method or the regression method as follows:

8.5.3.1 *Averaged Method*—Calculate  $C_1$ , the average of the concentrations at the time  $t_1$  that confirmed the uniformity of concentration criterion (8.4). Calculate  $C_2$ , the average of the concentrations at the time  $t_2$  that confirmed the uniformity of concentration criterion at the end of the test (8.4.1). Calculate mean air change rate  $\bar{A}$  by Eq 2:

$$\bar{A} = [\ln C(t_2) - \ln C(t_1)] / (t_2 - t_1) \quad (2)$$

8.5.3.2 *Optional Regression Method*—Calculate  $C_r$ , the average of the concentrations for the time period ( $t$ ) after satisfying the uniformity of concentration criterion (8.4). Plot the data on axes of  $\ln C(t)$  against  $t$ , as illustrated in Fig. 2. With the assumption of constant air change, the following relationship holds:

$$\ln C(t) = -At + \ln C(0) \quad (3)$$

Perform a regression of  $\ln C(t)$  against  $t$ . In a typical regression program on a hand-held calculator or spreadsheet program, one performs a regression on  $Y$  against  $X$  to find the constants  $a$  and  $b$  in the relationship:

$$Y = aX + b \quad (4)$$

In this case  $A$  corresponds to  $a$ ,  $\ln C(0)$  corresponds to  $b$ ,  $\ln C(t)$  corresponds to  $Y$ , and  $t$  corresponds to  $X$ . Establish confidence intervals for  $A$ , according to Appendix X3.1.

8.5.4 *Reporting of Ancillary Measurements*—Refer to 15.4 for reporting of ancillary measurements.

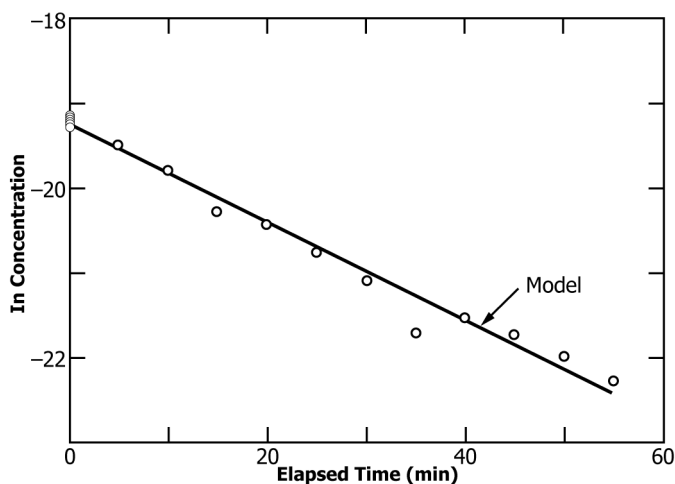

FIG. 2 Concentrations and Estimate of Concentrations Plotted Logarithmically

### 9. Procedure for the Constant Injection Test Method

9.1 *Summary*—To determine the average air change flow, inject tracer gas uniformly into the zone at a known, constant rate, ensure a uniform concentration, and then measure tracer gas concentration at known times. Calculate the average air change flow for the measurement period as the product of the tracer gas flow rate times the average of the inverses of measured concentration less a correction for the beginning and ending concentrations:

$$A = \frac{\left( Q_{tracer} \left[ \frac{1}{C} \right]_{avg} - \frac{V_{zone}}{t2 - t1} \ln \left[ \frac{C2}{C1} \right] \right)}{V_{zone}} \quad (5)$$

It is not necessary to know the volume of the zone if the beginning and ending concentrations used in the calculation are approximately equal and the equation above reduces to:

$$A = \frac{\left( Q_{tracer} \left[ \frac{1}{C} \right]_{avg} \right)}{V_{zone}} \quad (6)$$

Or for flow:

$$Q = Q_{tracer} \left[ \frac{1}{C} \right]_{avg} \quad (7)$$

Test the assumption of constant air change for the time period with an optional analysis of confidence intervals of the tracer gas concentrations after equilibrium has occurred. Fig. 3 gives a simplified overview of this test method.

#### 9.2 Preparation:

9.2.1 *Ancillary Measurements*—Refer to 11.1. The constant injection technique requires determination of zone volume (15.3) in the presence of non-steady-state air change flow.

9.2.2 *Zonal Operation*—Prepare the zone according to 11.2.

9.2.3 *Tracer Gas Injection Flow Rate and Initial Volume*—Determine the volume flow rate of the tracer gas to be injected  $Q_{tracer}$  according to the following steps:

9.2.3.1 Estimate the volume of the zone being measured  $V_{zone}$  in the same volume units as  $Q_{tracer}$

9.2.3.2 Estimate the air change rate  $A$  in the zone and convert it into  $A_{est}$  in the time units of  $Q_{tracer}$

9.2.3.3 Determine the target tracer gas concentration  $C_{target}$  that is mid-range in the detection limits of the gas analyzer, and

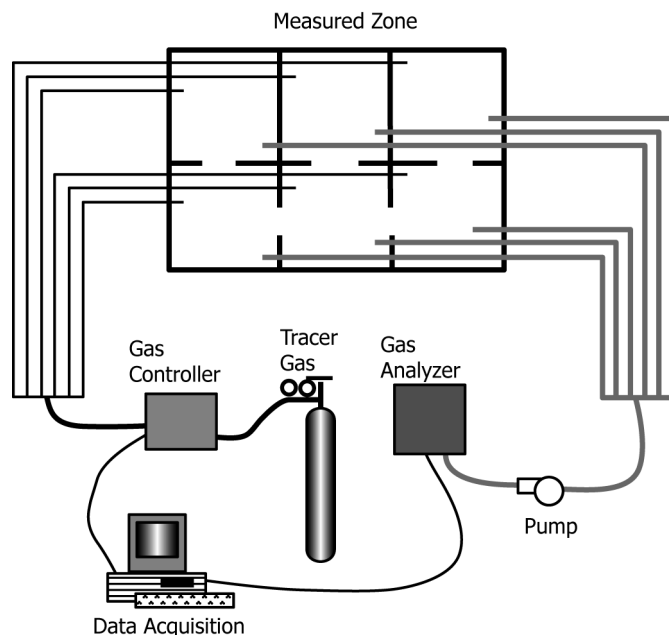

FIG. 3 Schematic Diagram of the Apparatus for the Constant Injection Method

9.2.3.4 Compute the following:

$$Q_{tracer} = C_{target} \times V_{zone} \times A_{est} \quad (8)$$

Eq 1 presents one method used to calculate an initial dose of tracer gas  $C(0) \approx C_{target}$  in order to obtain a more rapid tracer gas concentration equilibrium.

9.2.4 *Sampling*—Emplace the desired apparatus for sampling, according to one of the methods described in Section 13. Automated sampling (13.2) offers a convenient means to obtain a time series. Place the intake of each sampling unit away from tracer gas injection points.

9.3 *Tracer Gas Injection*—Inject tracer gas at a constant, known rate; metered injection (12.3) is one method. Record the starting time, duration, and rate  $Q_{tracer}$  of the injection. Also note any initial measured dose of tracer gas used to achieve an equilibrium. Distribute the tracer gas in the zone according to 12.4.3 in order to meet the uniformity of concentration criterion of 12.4.1. If the equilibrium concentration falls outside of the range for accurate measurement, adjust the flow rate appropriately. Do not use concentration data that are outside the 5% precision range of the analyzer.

9.3.1 *Tracer Gas Injection Uncertainty and Bias*—The uncertainty of the tracer gas injection rate shall be less than 2%. The bias of the assumed injection rate shall be no more than 2% of the true rate.

9.4 *Sampling*—First, perform spatial sampling to confirm adequate uniformity of concentration using 13.3. When the uniformity of concentration criterion 12.4.1 is confirmed, then sample as follows:

9.4.1 *Spatial Sampling*—At a minimum, take a second set of spatial samplings (13.3) at the end of the sampling period, for the period  $T_{tesr}$ . Check for tracer gas sources in adjacent spaces according to 13.4.3.

9.4.2 *Time Series Sampling*—Take a representative sample or set of spatial samples over a consistent timeframe for the period  $T_{test}$ . A minimum of five such samples or five sets of spatial samples is required during the measurement period. Compute the average air flow rate with these data using Eq 7.

9.4.3 *Concentration Equilibrium*—If one chooses to test the assumption of constant air change for the time period, then one shall continue to sample (9.4.2) after equilibrium has occurred. The criterion for equilibrium shall have been met if:

$$\left| \frac{C_{final} - C_{initial}}{T_{test}} \right| < 0.05 \frac{Q_{tracer}}{V_{zone}} \quad (9)$$

If one starts with a zero tracer gas concentration in the zone and injects at a constant rate, the tracer gas reaches 95 % of the equilibrium concentration within the zone after a period of time,  $T_{crit} = 3/A$ . So, for  $A = 1, 2,$  and  $3$  per hour,  $T_{crit} = 3, 1.5,$  and  $1$  hours, respectively.

9.5 Analysis:

9.5.1 *Analyze Tracer Gas Concentrations*—Analysis of tracer gas concentration shall occur either on site concurrently with the sampling process, using network sampling (13.2.1) connected to a gas analyzer, or off site, if the samples are stored in sealed, labeled containers. Note that if off-site analysis reveals that the mixing or equilibrium criterion has been violated, it is too late to remedy the problem with the measurement. Analyze and record the tracer gas concentration of each sample, together with the sampling time and location, according to the procedures in Section 14.

9.5.2 *Confirm Uniformity of Concentration*—Assess the concentrations of the spatial samplings for uniformity of concentration, according to 12.4.1. Confirm uniformity of concentration prior to the time of any grouping of points that is used to calculate air change flows. Estimate measurement precision using 14.1.3.

9.5.3 *Calculate Air Change Flow*—Calculate the average air change flow for the measurement period using time series tracer gas concentration data (9.5.3.1). One may test the assumption of constant air change for the measurement period (9.5.3.2) after an equilibrium tracer gas concentration has occurred.

9.5.3.1 *Average Air Change Flow*—Compute average air change flow with Eq 10.

$$Q = Q_{tracer} \left[ \frac{1}{C} \right]_{avg} - \frac{V_{zone}}{(t_2 - t_1)} \ln \left[ \frac{C_2}{C_1} \right] \quad (10)$$

The uncertainty in the zone volume shall be less than 15 % and the concentration shall never go outside  $\pm 20$  % of the average concentration. However, if the zone volume is known to 5 %, then the concentration shall vary by up to  $\pm 40$  %. If these conditions are violated, then the user shall do an error analysis (X6.2). Appendix X5 contains one method to measure zone volume. One minimizes the need to know the volume of the zone if the beginning and ending concentrations used in the calculation are close to equal, and Eq 9 is satisfied.

9.5.3.2 *Test for Constant Air Change Flow*—If one has achieved an equilibrium tracer gas concentration (9.4.3), then one may test the assumption of constant air change flow by calculating  $Q$  in Eq 10, using individual  $C$  data. Application of

a confidence interval calculation (X3.2) to these  $Q$  values tests how far the air change flow is from constant.

9.5.4 *Correlation with Ancillary Measurements*—Refer to 15.4 for reporting of ancillary measurements.

10. Procedure for the Constant Concentration Test Method

10.1 *Summary*—To monitor changing air change flow, measure and control tracer gas at a constant concentration with automated equipment. The equipment measures tracer gas concentration and then injects enough tracer gas into the zone to maintain a desired uniform concentration. Calculate the air change flow for each measurement interval from the ratio of the required additional tracer gas to the desired concentration. Fig. 4 gives a simplified overview of this test method. With this technique one is able to achieve a uniform tracer gas concentration in many single zones with complex geometries.

10.2 Preparation:

10.2.1 *Ancillary Measurements*—Refer to 11.1.

10.2.2 *Zonal Operation*—Prepare the zone according to 11.2.

10.2.3 *Tracer Gas Injection Flow Rate and Initial Volume*—This technique requires automated, switched, network injection (12.3.2.2). Connect the injection apparatus to the gas metering device and to the computer controlling the process of switching, sampling, and gas injection. Determine the target tracer gas concentration  $C_{target}$  that is mid-range in the detection limits of the gas analyzer. Wait for the apparatus to achieve the target concentration. Eq 1 is another method to calculate an initial dose of tracer gas  $C(0) \approx C_{target}$  in order to reach the target concentration more rapidly.

10.2.4 *Sampling*—This technique requires automated, switched, network sampling (13.2.1 and 13.2.1.2). Connect the sampling apparatus to the gas analyzer and to the computer controlling the process of switching, sampling and gas injection. An important limitation on the accuracy of this technique

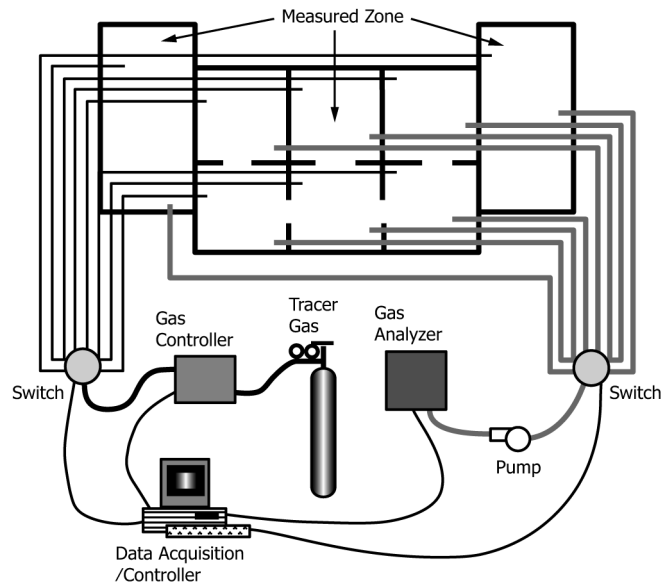

FIG. 4 Schematic Diagram of the Apparatus Used for the Constant Concentration Technique