



Designation: **E2446—16** E2446 – 23

## Standard Practice for Manufacturing Characterization of Computed Radiography Systems<sup>1</sup>

This standard is issued under the fixed designation E2446; the number immediately following the designation indicates the year of original adoption or, in the case of revision, the year of last revision. A number in parentheses indicates the year of last reappraisal. A superscript epsilon ( $\epsilon$ ) indicates an editorial change since the last revision or reappraisal.

### 1. Scope

1.1 This practice ~~describes~~covers the manufacturing characterization of computed radiography (CR) systems, consisting of a particular phosphor imaging plate (IP), scanner, software, scanner operational parameters, and an image display monitor, in combination with specified metal screens for industrial radiography.

1.2 The practice defines system tests to be used to characterize the systems of different suppliers and make them comparable for users.

1.3 This practice is intended for use by manufacturers of CR systems or certification agencies to provide quantitative results of CR system characteristics for nondestructive testing (NDT) user or purchaser consumption. Some of these tests require specialized test phantoms to ensure consistency of results among suppliers or manufacturers. These tests are not intended for users to complete, nor are they intended for long term stability tracking and lifetime measurements. However, they may be used for this purpose, if so desired. Practice E2445 describes tests which are intended for users to observe the CR performance and test the long term stability.

1.4 The CR system performance is described by the basic spatial resolution, contrast, signal and noise parameters, and the equivalent penetrometer sensitivity (EPS). Some of these parameters are used to compare with DDA characterization and film characterization data (see Practice E2597 and Test Method E1815).

NOTE 1—For film system characterization, the signal is represented by the optical density of 2 (above fog and base) and the noise as granularity. The signal-to-noise ratio is normalized by the aperture (similar to the basic spatial resolution) of the system and is part of characterization. This normalization is given by the scanning circular aperture of 100  $\mu\text{m}$  of the micro-photometer, which is defined in Test Method E1815 for film system characterization.

1.5 The measurement of CR systems in this practice is restricted to a selected radiation quality to simplify the procedure. The properties of CR systems will change with radiation energy but not the ranking of CR system performance. Users of this practice may carry out the tests at different or additional radiation qualities (X-ray or gamma ray) if required.

1.6 The values stated in SI are to be regarded as the standard.

1.7 *This standard does not purport to address all of the safety concerns, if any, associated with its use. It is the responsibility of the user of this standard to establish appropriate ~~safety and health practices and to~~safety, health, and environmental practices and determine the applicability of regulatory limitations prior to use.*

<sup>1</sup> This practice is under the jurisdiction of ASTM Committee E07 on Nondestructive Testing and is the direct responsibility of Subcommittee E07.01 on Radiology (X and Gamma) Method.

Current edition approved ~~June 1, 2016~~ June 15, 2023. Published ~~June 2016~~ August 2023. Originally approved in 2005. Last previous edition approved in ~~2015~~ 2016 as E2446—15: E2446 – 16. DOI: 10.1520/E2446-16.10.1520/E2446-23.

1.8 *This international standard was developed in accordance with internationally recognized principles on standardization established in the Decision on Principles for the Development of International Standards, Guides and Recommendations issued by the World Trade Organization Technical Barriers to Trade (TBT) Committee.*

## 2. Referenced Documents

### 2.1 ASTM Standards:<sup>2</sup>

- E746 Practice for Determining Relative Image Quality Response of Industrial Radiographic Imaging Systems
- E1165 Test Method for Measurement of Focal Spots of Industrial X-Ray Tubes by Pinhole Imaging
- E1316 Terminology for Nondestructive Examinations
- E1815 Test Method for Classification of Film Systems for Industrial Radiography
- E2002 Practice for Determining Image Unsharpness and Basic Spatial Resolution in Radiography and Radioscopy
- E2007 Guide for Computed Radiography
- E2033 Practice for Radiographic Examination Using Computed Radiography (Photostimulable Luminescence Method)
- E2445 Practice for Performance Evaluation and Long-Term Stability of Computed Radiography Systems
- E2597 Practice for Manufacturing Characterization of Digital Detector Arrays
- E2903 Test Method for Measurement of the Effective Focal Spot Size of Mini and Micro Focus X-ray Tubes

### 2.2 ISO Standard:<sup>3</sup>

- ISO 17636-2 Non-Destructive Testing of Welds—Radiographic Testing—Part 2: X- and Gamma Ray Technologies with Digital Detectors

## 3. Terminology

3.1 *Definitions*—The definition of terms relating to gamma- and X-radiography, which appear in Terminology E1316, Guide E2007, and Practice E2033, shall apply to the terms used in this practice.

3.2 *Definitions of Terms Specific to This Standard:*

3.2.1 *computed radiography system (CR system)*—A complete system of a storage phosphor imaging plate (IP), a corresponding read out unit (scanner or reader), software, scanner operational parameters, and an image display monitor, which converts the information of the IP into a digital image (see also Guide E2007).

3.2.2 *computed radiography system performance level*—A particular group of CR performance levels, which is characterized by an SNR<sub>N</sub> (signal-to-noise (normalized signal-to-noise ratio) range, an interpolated basic spatial resolution range  $iSR_b^{detector}$  and equivalent penetrameter sensitivity (EPS) shown in Table 4 in a specified exposure range.

3.2.3 *gain/amplification*—Opto-electrical gain setting of the scanning system.

3.2.4 *ISO speed  $S_{IPx}$* —Defines the speed of a CR system and is calculated from the reciprocal dose value, measured in Gray (Gy), which is necessary to obtain a specified minimum SNR<sub>N</sub> of a CR system performance level.

3.2.5 *linearized signal intensity*—a numerical signal value of a picture element (pixel) of the digital image, which is proportional to the radiation dose. The linearized signal intensity is zero, if the radiation dose is zero.

## 4. Significance and Use

4.1 There are several factors affecting the quality of a CR image including the basic spatial resolution of the IP system, geometrical unsharpness, scatter and contrast sensitivity. There are several additional factors (for example, software and scanning parameters) that affect the accurate reading of images on exposed IPs using an optical scanner.

4.2 This practice is to be used to establish a characterization of CR system by performance levels on the basis of a normalized SNR, interpolated basic spatial detector resolution and EPS. The CR system performance levels in this practice do not refer to any particular manufacturers' imaging plates. A CR system performance level results from the use of a particular imaging plate together with the exposure conditions, standardized phantom, the scanner type, and software and the scanning parameters. This characterization system provides a means to compare differing CR technologies, as is common practice with film systems, which

<sup>2</sup> For referenced ASTM standards, visit the ASTM website, www.astm.org, or contact ASTM Customer Service at service@astm.org. For *Annual Book of ASTM Standards* volume information, refer to the standard's Document Summary page on the ASTM website.

<sup>3</sup> Available from International Organization for Standardization (ISO), 1, ch. de la Voie-Creuse, CP 56, CH-1211 Geneva 20, Switzerland, <http://www.iso.org>.

guides the user to the appropriate configuration, IP, and technique for the application at hand. The performance level selected may not match the imaging performance of a corresponding film class because of the difference in the spatial resolution and scatter sensitivity. Therefore, the user should always use IQIs for proof of contrast sensitivity and basic spatial resolution.

4.3 The measured performance parameters are presented in a characterization chart. This enables users to select specific CR systems by the different characterization data to find the best system for his specific application.

4.4 The quality factors can be determined most accurately by the tests described in this practice. Some of the system tests require special tools, which may not be available in user laboratories. Simpler tests are described for quality assurance and long term stability tests in Practice E2445.

4.5 Manufacturers of industrial CR systems or certification agencies will use this practice. Users of industrial CR systems may use Practice E2445 or perform some of the described tests and measurements outlined in this practice, provided that the required test equipment is used and the methodology is strictly followed. Any alternative methods or radiation qualities may be applied if equivalence to the methods of this practice is proven to the appropriate cognizant engineering organization.

4.6 The publication of CR system performance levels will enable specifying bodies and contracting parties to agree to particular system performance level, as a first step in arriving at the appropriate settings of a system, or the selection of a system. Confirmation of necessary image quality shall be achieved by using Practice E2033.

## 5. Apparatus

5.1 CR system evaluation depends on the combined properties of the phosphor imaging plate (IP) type, the scanner and software used, and the selected scan parameters and image display monitor. Therefore, documentation for each test shall include the IP type, scanner, software, scan parameters, and image display monitor, and the results shall be calculated and tabulated before arriving at a performance assignment. The applied test equipment for SNR measurement (Fig. 1) and algorithm 6.1.1 correspond to Test Method E1815. The recommended thickness for aperture test object (diaphragm) is 10.2 mm (0.4 in.) of Pb. The SDD shall be at least 1 m (39 in.). Do not use any material (for example, lead) behind the cassette and leave a free space of at least 1 m (39 in.) behind the cassette or use a steel screen of about 0.5 mm (0.02 in.) and a lead plate of  $\geq 2 \geq 2$  mm (0.08 in.) just behind the cassette (steel screen is positioned between cassette and lead) and in contact with the cassette.

5.2 The step wedge method (Fig. 2) describes a simpler procedure for SNR measurement than described in Test Method E1815, which permits obtaining similar results with less expense, and less accuracy.

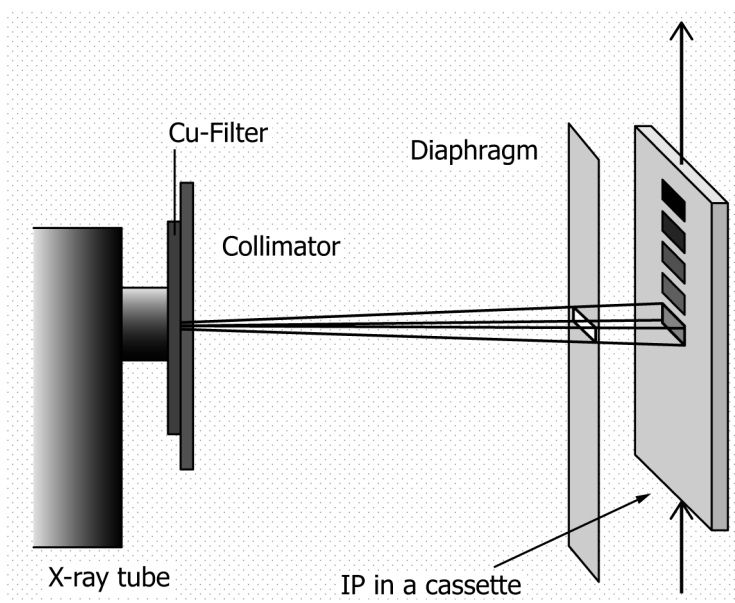

FIG. 1 Scheme of Experimental Arrangement for the Step Exposure Method

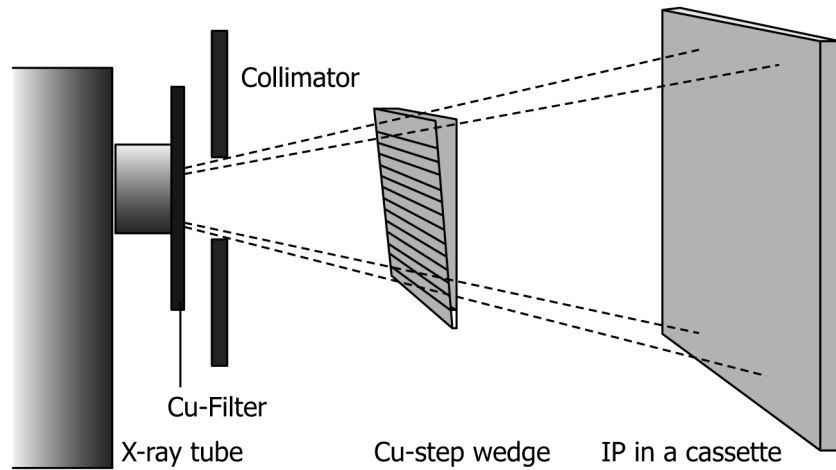

FIG. 2 Scheme for the Measurement of the SNR by the Step Wedge Method

## 6. Procedure for Quantitative Measurement of Image Quality Parameters

### 6.1 Measurement of the Normalized Signal-to-Noise Ratio ( $SNR_N$ )

6.1.1 *Step Exposure Method*—For measurement of the SNR, the following steps are taken (see also Test Method E1815):

6.1.1.1 The IP shall be positioned in front of an X-ray tube with tungsten anode. Make the exposures with an ~~8 mm~~ 8 mm (0.32 in.) copper filter at the X-ray tube and the kilovoltage set such that the half value layer in copper is ~~3.5 mm~~ 3.5 mm (0.14 in.). The kilovoltage setting will be approximately 220 kV. Metal screens can be used in the cassette if the manufacturer recommends its application. The focal spot size is not relevant for SNR measurements.

6.1.1.2 Determine the required exact kilovoltage setting by making an exposure (or an exposure rate) measurement with the detector placed at a distance of at least 750 mm (29.5 in.) from the tube target and an 8 mm (0.32 in.) copper filter at the tube. Then make a second measurement with a total of 11.5 mm (0.45 in.) of copper at the tube. These filters should be made of 99.9 % pure copper.

6.1.1.3 Calculate the ratio of the first and second readings. If this ratio is not 2, adjust the kilovoltage up or down and repeat the measurements until a ratio of 2 (within 5 %) is obtained. Record the setting of kilovoltage for use with the further IP tests.

6.1.1.4 The scanner shall read with a dynamic range of  $\geq 12$  bit and operate at its highest spatial resolution or a basic spatial resolution for which the characterization shall be carried out. Background and anti-shading correction may be used before the analysis of data, if it relates to the standard measurement procedure for all measurements.

6.1.1.5 The procedure shall be carried out and documented for one or more agreed sets of scanner parameters per imaging plate type. It is recommended to use the standard parameters of the CR scanner as given by the manufacturer and the parameter set for the highest resolution.

6.1.1.6 IPs are exposed under the conditions described above: A signal ( $S$ ) and noise ( $\sigma$ ) or the quotient, the signal to noise ratio ( $SNR$ ) vs. versus dose and pixel value curve shall be measured—see Fig. 3 and Fig. 4). It is important that the exposure of the IP for the SNR measurements be spatially uniform. Any non-uniformities in X-ray transmission of the cassette front, or defects in a front metal screen or in the phosphor layer itself could influence the SNR measurement. No major scratches or dust shall be visible in the measurement area. Therefore, exercise considerable care in selection and placement of the aperture, selection, and maintenance of the cassette, the metal screens (if any), and the imaging plate. To achieve a uniform area of interest on to the IP, the following standard protocol is recommended. Other approaches may be used as long as a uniform exposure is created. At least twelve areas (test areas) of  $\geq 400$  mm<sup>2</sup> (0.62 in.<sup>2</sup>) are evenly exposed on the same IP over the full working range of dose. Due to the different construction principles of scanners, the measurement shall be performed for different pixel sizes as recommended by the manufacturer. A waiting time of 15 minutes min is recommended between exposure and scan of the IPs to avoid distortions by fading effects. Typically, the characterization is performed for selected parameter sets only if agreed by the manufacturer and the certifying laboratory. The digital read-out pixel values shall be calibrated in such a way that they are linear in relation to the radiation dose, which corresponds to the photo stimulated luminescence (PSL) intensity of the exposed IPs. These calibrated pixel

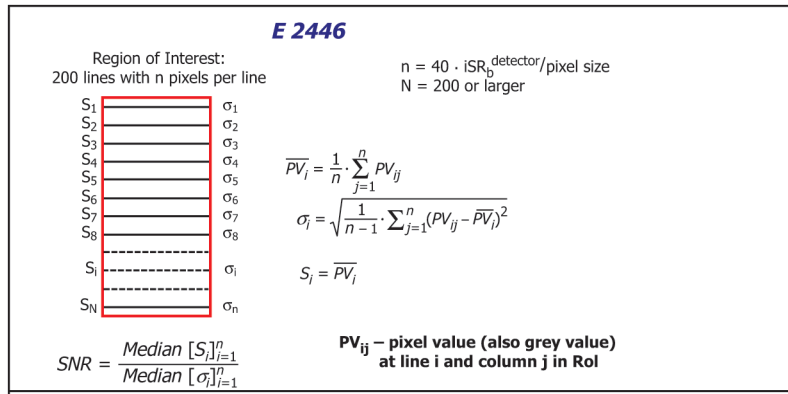
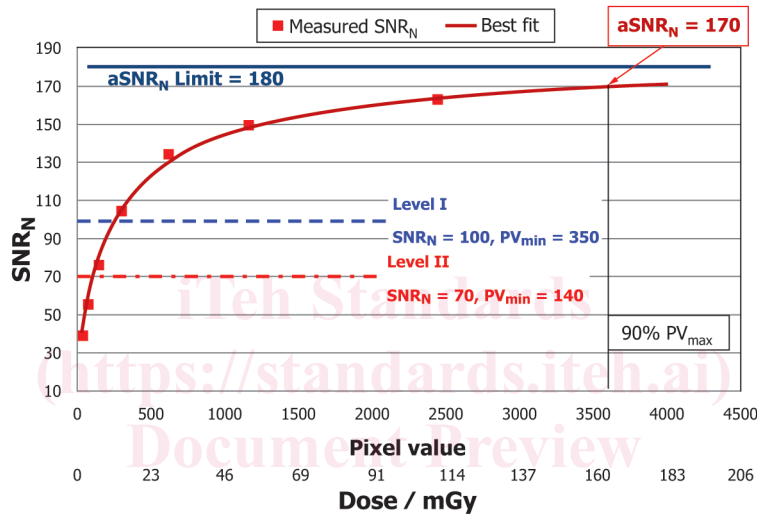

FIG. 3 Scheme for Measurement of SNR in the RoI with Pixel Values PV<sub>ij</sub>



NOTE 1—The tested CR system qualifies for:

Level I performance from PV 350 – 4095 (see Table 4)

Level II performance from PV 140 – 4095 (see Table 4)

PV<sub>max</sub> = 4095, as determined with procedure of 6.4

FIG. 4 Example Plot of Measured SNR<sub>N</sub> Versus PV (12 bit system,  $iSR_b^{detector} = 70 \mu\text{m}$ ) for Determination of Level I and II Performance Range (see 6.4)

values shall be used for the calculation of the SNR to obtain a reliable result. Measurements shall be made on at least six different samples, and the results are to be averaged for each of the twelve or more dose levels measured.

6.1.1.7 The signal (*S*) and noise (standard deviation  $\sigma$ ) of the measured pixel values shall be calculated from a region of interest (RoI) without shading or artifacts. Sample SNR values shall be taken in different regions of the image area under test to ensure that SNR values are within 10 %. The size of the RoI used to measure the mean signal and noise shall be at least 4040 pixels by 200 pixels.

6.1.1.8 An example technique for ensuring reliable signal-to-noise measurements is described in the following. This can be achieved using a commonly available image processing tool. The signal and noise shall be calculated from a data set of 8000 values or more per exposed area. The unfiltered data set is subdivided into 200 groups or more with 40 values per group (200 or more profile lines with 40 pixels per profile). For each group with index *i*, the signal *S<sub>i</sub>* and the noise value  $\sigma_i$  are calculated from the pixel values *PV<sub>ij</sub>* in the region of interest (RoI). An increased number of groups per RoI yields a better (lower) uncertainty of the result. Fig. 3 describes the measurement procedure in detail and the equations to use. If

$iSR_b^{detector} > \text{pixel size}$ , it is recommended to use a profile line width (*lw*) of:

$$lw(\text{pixel}) = 40 \cdot iSR_b^{detector} / \text{pixelsize} \quad (1)$$

$$lw_{\text{pixel}} = 40 \cdot \frac{SR_b^{detector}}{\text{pixelsize}} \quad (1)$$

6.1.1.9 The final value  $S$  is obtained by the median of all  $S_i$  values. The final  $\sigma$  value is obtained by the median of all  $\sigma_i$  values. SNR shall be calculated as reference value  $SNR_N$ , normalized to a resolution of  $88.6 \mu\text{m}$ , which is related to a squared aperture (pixel size of  $88.6 \mu\text{m}^2$  by  $88.6 \mu\text{m} \times 88.6 \mu\text{m}$ ). The final value  $SNR_N$  is calculated by considering the measured interpolated basic spatial resolution  $iSR_{bmax}$ , which is the larger value of both, measured in fast and slow scan direction (see 6.5):

$$SNR_N = SNR \cdot \frac{88.6 \mu\text{m}}{iSR_{bmax}} \quad (2)$$

$$SNR_N = SNR \cdot \frac{88.6 \mu\text{m}}{iSR_b^{detector}} \quad (2)$$

where:

$iSR_{bmax}$  = interpolated maximum value of basic spatial resolution in  $\mu\text{m}$  as measured in 6.5.

$iSR_b^{detector}$  = interpolated maximum value in  $\mu\text{m}$  of both basic spatial resolution values as measured in fast and slow scan direction (see 6.5).

NOTE 2—Test Method E1815 requires the use of a micro-photo densitometer with circular aperture of  $100 \mu\text{m}$  diameter for the measurement of granularity  $\sigma_D$  of films. Because the pixels in digital images are organized in squares, the corresponding pixel size is calculated by  $\text{sqrt}((100 \mu\text{m})^2 \pi / 4) = 88.6 \mu\text{m}$  ( $1 \mu\text{m} = 3.93701\text{E-}05 \text{ in.}$ ). This value of  $88.6 \mu\text{m}$  for normalization was selected for comparison of noise in digital images with film granularity.

6.1.1.10  $SNR_N$  shall be plotted versus pixel value (Fig. 4) and versus exposure dose.

6.1.2 *Step Wedge Method (Manufacturer Test and Enhanced User Test)*—The measurement of the SNR can be performed with less accuracy using a step wedge, as shown in Fig. 2. This method, if approved by the cognizant engineering organization (CEO), may be of interest for users to determine the SNR with less expensive equipment:

6.1.2.1 For that purpose, a step wedge of Cu, with at least twelve equally increasing steps, shall be used as in the arrangement shown in Fig. 2. The selection of the X-ray voltage shall be as described in 6.1.1.1. The maximum thickness of the step wedge shall absorb 90 % of the radiation of the central beam, which requires a thickness of  $11.7 \text{ mm}$  ( $0.46 \text{ in.}$ ). To cover a range of two or more orders of magnitude of the radiation dose, at least two suitable and different exposures with adequate exposure time or tube current (mA) shall be made. A waiting time of 10 minutes is recommended between exposure and scan of the IPs to avoid distortions by fading effects. The distance between step wedge and IP shall be  $\geq 500 \text{ mm}$  ( $19.69 \text{ in.}$ ) to reduce the influence of scattered radiation. A magnification of  $2\times$  is recommended. A beam collimator shall be used to restrict exposures to the step wedge only. X-ray voltage and filtering shall be selected in accordance with 6.1.1.1 through 6.1.1.3.

NOTE 3—X-ray penetration through Cu-steps of different thickness is distorted by beam hardening and suitable adjustment of exposure is required.

6.1.2.2 The projected area of each step shall be about  $20 \text{ mm}$  by  $20 \text{ mm}$  ( $\geq 400 \text{ mm}^2$ ). SNR values should not be taken closer than four times the  $iSR_b^{image}$  to an edge.

6.1.2.3 All details for the measurement of the SNR shall correspond to 6.1.1.6 – 6.1.1.9. The graphical analysis shall be based on the plot of  $SNR = f(\sqrt{\text{exposure} \cdot e^{-\mu_{Cu} \cdot w_{Cu}}})$  where  $\mu_{Cu}$  is the absorption attenuation coefficient,  $w_{Cu}$  is the wall thickness of the corresponding step of the step wedge, and the value “Exposure” “exposure” is calculated from exposure time (seconds) multiplied by tube current (mA).

NOTE 4—For accurate plots, it is necessary to consider the wall thickness dependence of  $\mu_{Cu}$  on the wall thickness (beam hardening). The influence of scattered radiation should be reduced by exact collimation. Different exposures with different exposure time or mA-settings are recommended for the required plot. The exposure value (mAs) of the different exposures of the step wedge target should be increased by about 5.

## 6.2 Contrast Sensitivity by Equivalent Penetrameter Sensitivity (EPS)

6.2.1 The characterization by performance levels being based on the EPS can be performed with less accuracy on basis of visual evaluation of radiographs than by the quantitative  $SNR_N$  step exposure method using the following procedure on basis of Practice E746, as illustrated in Fig. 5. The standard procedure is the EPS measurement at 90% of the maximum achievable pixel value,  $PV_{max}$  (see also 6.3 and Fig. 4) with a steel absorber as described in Practice E746 and the measurement of the effective attenuation

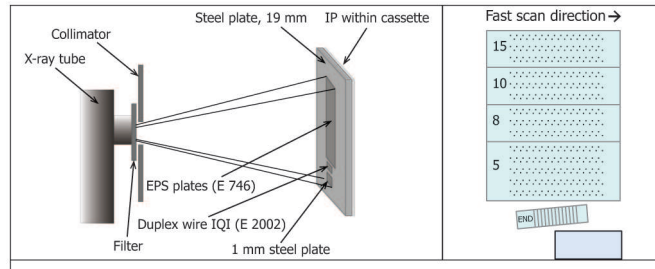

FIG. 5 Illustration of EPS Characterization Set Up (left) and Test Phantom (right). The Duplex Wire IQI is Tilted Approximately 5°.

coefficient. Optionally, the complete plot of EPS vs. dose curve may be measured (Fig. 5) and  $PV_{min}$  may be determined as shown in Fig. 6 for the different performance levels. Other fine grained materials than mild steel and different radiation qualities may be used if requested for other applications as, for example, testing of light materials in aerospace applications.

6.2.2 Required Measurements and Evaluations—These evaluations are adapted from Practices E746 and E2002. Image quality indicators from these standards and a 1 mm steel plate for measurement of the relative contrast are arranged in a standard phantom (Fig. 5) and exposed with a (Practice E746) 19 mm (3/4 in.) absorber of mild steel to qualify. The tube voltage shall be 220 kV with 2 mm Cu in front of the tube port instead of 200 kV as recommended in Practice E746.

6.2.2.1 The EPS value shall be determined at least at 90 % of the  $PV_{max}$ . Alternatively, the EPS performance may be determined in the characterized linear or linearized PV range as illustrated in Fig. 5.

6.2.2.2 Determination of Relative Contrast  $C_{1mm}$ —Fig. 5 illustrates a typical layout for a 19 mm (3/4 in.) 19 mm (3/4 in.) thick steel plate, at least 20 cm (≈ 8 in.) wide by 25 cm (≈ 10 in.) long, containing a series of Practice E746 EPS plaques of varying thicknesses and hole sizes, a 1 mm steel plate, and a Practice E2002 unsharpness gauge with duplex wires oriented approximately 5° tilted to the plate edge direction for monitoring of the influence of the geometric unsharpness and unsharpness; all IQIs are situated on the source side. The 19 mm 19 mm (3/4 in.) steel plate should cover the complete IP and IP cassette. The X-ray source shall be collimated to the 19 mm 19 mm (3/4 in.) plate only. The surface finish of the absorber plate shall be no worse than RMS 250. If the EPS absorber plate does not cover the entire IP, the IP shall be masked with lead around the absorber plate.

6.2.3 EPS characterization by Practice E746—EPS characterization by Practice E746. For each exposure (data point in Fig. 6) at different dose of the set of Fig. 5, determine the lowest (best) EPS performance of each exposure by determining the duplex row (Practice E746 illustrates step layout and corresponding EPS %), where a minimum of 15 holes out of 30 holes in each duplex row (50% (50 % rule) are clearly visible. Table 1 provides EPS values (see also Practice E746) for each visible duplex row on the

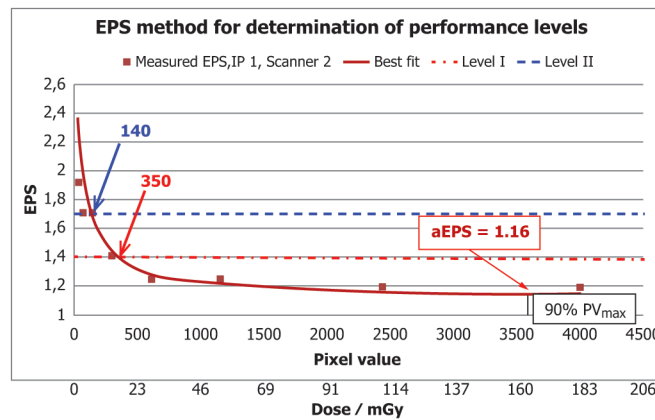

NOTE 1—The tested CR system qualifies for:  
 —Level I performance from PV 350–4095 (see Table 4)  
 —Level II performance from PV 140–4095 (see Table 4)  
 — $PV_{max}$  = 4095, as determined with procedure of 6.4  
 — $aEPS$  = 1.16

FIG. 6 Example Plot for Measured of EPS Versus PV (12 bit system,  $iSR_{D,detector} = 70 \mu m$ ) for Determination of Level I and II Performance Range

**TABLE 1 EPS Values on Standard 19-mm (¾-in.) Absorber Plate as a Function of Step and Hole Size**

Plaque Number	Step Size mm (in.)	Hole Size mm (in.)	EPS %
15	0.38 (0.015)	0.71 (0.028)	1.92
		0.64 (0.025)	1.82
		0.58 (0.023)	1.71
10	0.25 (0.010)	0.79 (0.031)	1.66
		0.71 (0.028)	1.57
		0.64 (0.025)	1.49
8	0.20 (0.008)	0.71 (0.028)	1.41
		0.64 (0.025)	1.33
		0.58 (0.023)	1.25
5	0.13 (0.005)	0.81 (0.032)	1.19
		0.71 (0.028)	1.12
		0.64 (0.025)	1.05
		0.58 (0.023)	1.00
		0.50 (0.020)	0.94

specified standard of a 19-mm (¾-in.) absorber plate of steel. Plot the EPS (in %) taken with the set of Fig. 5 in a graph as presented in Fig. 6 that corresponds with the qualifying hole size row of Table 1, its corresponding exposure identification, and pixel value.

6.2.3.1 The source-to-detector distance (SDD) shall be at least 1 m (39 in.). The geometric unsharpness,  $u_g$ , shall not exceed 50  $\mu$ m and  $u_g$  shall not exceed 20% of  $iSR_p^{detector}$ . The kilovoltage setting shall be selected corresponding to 6.1.1.1 – 6.1.1.3 and is approximately 220 kV for the steel absorber. No material (for example, lead) shall be used behind the cassette; free space of at least 1 m shall be left behind the cassette or a steel screen of about 0.5 mm (0.02 in.), and a lead plate of  $\geq 2$  mm (0.08 in.) shall be used just behind the cassette (steel screen is positioned between cassette and lead) and in contact with the cassette. The EPS method may be applied for materials other than steel by agreement of the CEO or the contracting parties.

Document Preview

**TABLE 2 Required Tests of Practice E2446 as described in Annex A1 and Annex A2 Required Result, and Required Results**

Required Test	Required Result
Geometric Distortion (by spatial linearity image quality indicators in Type I Test Phantom)	Fail if distortion > 2%
Geometric Distortion (by spatial linearity image quality indicators in CR Test Phantom, Annex A3, see Annex A1 for details.)	Fail if distortion > 2%
Laser Jitter (by T-target in Type I CR Test Phantom)	Not permitted
Laser Jitter (by T-target in CR Test Phantom, Annex A3, see Annex A1 for details.)	Not permitted
Laser Beam Scan Line Integrity (no test object required)	Not permitted
Laser Beam Scan Line Integrity (no test object required, see Annex A1 for details.)	Not permitted
Scan column dropout (no test object required)	Not permitted
Scan column dropout (no test object required, see Annex A1 for details.)	Not permitted
Scanner Slippage (by homogeneous strip slippage target in Type I CR Test Phantom)	Not permitted
Scanner Slippage (by homogeneous strip slippage target in CR Test Phantom, Annex A3, see Annex A1 for details.)	Not permitted
Imaging plate Artifacts (no test object required)	Not permitted
Erasure (high absorption object required)	Fail if > 2%
Erasure (high absorption object required, see Annex A2 for details.)	Fail if > 2%
Shading or banding (by homogeneous plate, three shading image quality targets in Type I)	Fail if more than $\pm 10\%$
Shading or banding (by homogeneous plate, three shading image quality targets in CR Test Phantom, Annex A3)	Fail if more than $\pm 10\%$
Test Results Shall be Reported, also in Case of Exceeding the Limits	Result to Report
PMT Non-linearity (by T-target in Type I CR Test Phantom)	Report if > 2%
PMT Non-linearity (by T-target in CR Test Phantom, Annex A3, see 6.6.2 for details and Annex A1)	Report if > 2%
Burn-In (high absorption object required)	Report if > 2%
Burn-In (high absorption object required, see Annex A2 for details)	Report if > 2%
Spatial Linearity (by spatial linearity image quality indicators in Type I CR Test Phantom)	Report if > 2%
Spatial Linearity (by spatial linearity image quality indicators in CR Test Phantom, Annex A3, see Annex A1 for details.)	Report if > 2%
Imaging plate response variation (no test object required)	Report if > $\pm 10\%$
Imaging plate response variation (no test object required, see Annex A2 for details.)	Report if > $\pm 10\%$
Optional Test on Request	Result to Report
Imaging Plate Fading (no test object required), optional test	Report fading in %, calculated from values measured at 5 min and 2 h.
Imaging Plate Fading (no test object required), optional test, see 6.6.1.2 and 6.6.1.3 and Annex A2 for details.	Report fading in %, calculated from values measured at 5 min and 2 h.



6.2.3.2 The interpolated basic spatial resolution as determined from the exposure through the absorber plate shall be no more than ~~10%~~ 10% worse than the interpolated basic spatial resolution as determined without the absorber plate at 220 kV (8 mm (8 mm Cu). If this is not achieved, the focal spot size (as measured by Test Methods E1165 or E2903) shall be reduced or the SDD shall be increased.

6.3 Linearity Test of Pixel Value Response for Linearized Values

6.3.1 Measured signal values (mean pixel values) of 6.1 or 6.2 are plotted versus exposure dose along a linear exposure scale for linear systems (see Fig. 7). Nonlinear systems shall be tested with a numeric linearization corresponding to the manufacturer’s conversion equation for linearization. The pixel value range characterization is valid only for the specific scanner operational parameters used, including photomultiplier tube gain, laser power, sampling resolution setting, and all other operator-adjustable scanner control parameters. Exposures should be approximately equally distributed within the qualified PV range. The linearity test shall be performed in the range from ~~10%~~ 10% to 90% of the full PV range. At least eight data points should be taken.

6.3.2 The measured pixel values shall not deviate from the linear fit more than 5%. If the linearity does not cover the full range, a PV<sub>max</sub> value shall be specified that shall not be exceeded in NDT practice.

6.3.3 No PV<sub>max</sub> characterization is required if the system is linear over the full scanner PV range to exposure dose.

NOTE 5—PV<sub>max</sub> specification is typically not required. Related to the observation that sometimes nonlinearities may appear, if readers scan IP areas that have been exposed with extraordinary high exposure dose values, the linearity test should cover the full PV range. Fading may also influence the linearity with increased exposure time.

6.4 Determination of Minimum Pixel Value, PV<sub>min</sub>

iTeh Standards  
(https://standards.itih.ai)

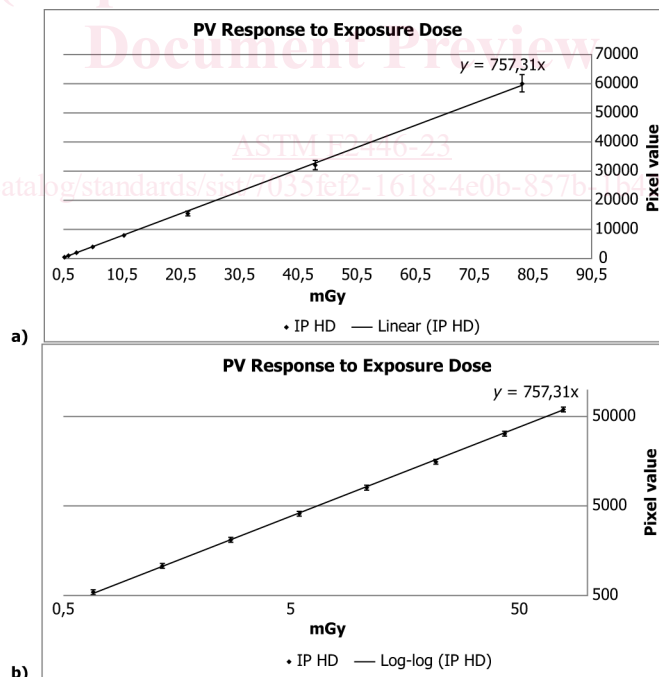

FIG. 7 PV Linearity Characterization for CR Systems with 5% Bars

- (a) The system is qualified successfully in the PV range from 0 to 65535 (16 bit system);
- (b) The error bars in the low intensity range can be evaluated better in the double logarithmic graph.

NOTE 1—X—distance  
Y—amplitude

- (a) The system is qualified successfully in the PV range from 0 to 65535 (16 bit system).
- (b) The error bars in the low intensity range can be evaluated better in the double logarithmic graph.

FIG. 8 Example for Measurement of the Modulation's Depth of Radiographs with Duplex Wire IQI  
(a) Image of Duplex Wire as Shown in a Radiograph

6.4.1 Determination of  $PV_{min}$  with the SNR Method—Method

6.4.1.1 Plot a graph of  $SNR_N$  versus mean pixel value  $PV_{mean}$  as a function as illustrated in Fig. 4.

**TABLE 3 Determination of ISO Speed ( $S_{ISO}$ ) from Dose  $K_S$  (in Gray) for an IP Read-Out Intensity of  $PV_{min}$  at the Characterized Performance Level as Determined from  $SNR_N$  and EPS Method**

Log <sub>10</sub> K <sub>S</sub>		ISO Speed ( $S_{ISO}$ )	ISO Speed ( $S_{ISO}$ )
From	To		
-4.66	< -4.55	40 000	
-4.55	< -4.45	32 000	
-4.45	< -4.35	25 000	
-4.35	< -4.25	20 000	
-4.25	< -4.15	16 000	
-4.15	< -4.05	12 500	
-4.05	< -3.95	10 000	
-3.95	< -3.85	8000	
-3.85	< -3.75	6300	
-3.75	< -3.65	5000	
-3.65	< -3.55	4000	
-3.55	< -3.45	3200	
-3.45	< -3.35	2500	
-3.35	< -3.25	2000	
-3.25	< -3.15	1600	
-3.15	< -3.05	1250	
-3.05	< -2.95	1000	
-2.95	< -2.85	800	
-2.85	< -2.75	640	
-2.75	< -2.65	500	
-2.65	< -2.55	400	
-2.55	< -2.45	320	
-2.45	< -2.35	250	
-2.35	< -2.25	200	
-2.25	< -2.15	160	
-2.15	< -2.05	125	
-2.05	< -1.95	100	
-1.95	< -1.85	80	
-1.85	< -1.75	64	
-1.75	< -1.65	50	
-1.65	< -1.55	40	
-1.55	< -1.45	32	
-1.45	< -1.35	25	
-1.35	< -1.25	20	

6.4.1.2 Use  $SNR_N$  versus  $PV$  correlation data as presented in Fig. 4 for the specific qualifying CR system to determine the minimum pixel value that provides the desired minimum  $SNR_N$  for the performance level as specified in Table 4.

6.4.1.3 Pixel values and  $SNR_N$  values shall be determined without the use of any digital filtering. Some scanner systems may provide degraded  $SNR$  or  $SNR_N$  values at very high pixel values and low gain. In the event that this occurs, a maximum pixel value ( $PV_{max}$ ) shall be specified as the upper linear  $PV$  without degradation of the plotted line.

6.4.1.4 When establishing minimum pixel values using this method, the specific scanner and its parameters used as well as the specific imaging plate type used shall be recorded for this characterization.

6.4.1.5 The minimum  $SNR_N$  values for specification of  $PV_{min}$  and  $PV_{max}$  (if required) for performance Special to Level III are provided in Table 4.

6.4.2 Determination of  $PV_{min}$  with the EPS Method—Method

TABLE 4 CR System Performance by Performance Levels

NOTE 1—The terminology of the CR performance levels is chosen in analogy to the film system classes of Test Method E1815. It is recommended to select the related CR performance levels for replacement of films with the classes: Special, T1, T2, T3. Nevertheless, CR performance and image quality change depending on exposure time, mA, kV and performance level in a different way than films. Therefore, no exact assignment can be made.

CR System Performance	Required Minimum SNR <sub>N</sub> (Normalized to SR <sub>N</sub> =88.6 μm)	Permitted Maximum $iSR_{b,detector}$ Value (μm)	Permitted Maximum Achieved EPS by E746 (%) <sup>A</sup>
CR Special	200	50	1.00
CR Level I	100	100	1.41
CR Level II	70	160	1.66
CR Level III	50	200	1.92

<sup>A</sup>E746 specifies the test for steel at 200-220-200 kV to 220 kV. If the measurement is performed with other materials or kV values, or both, user dependent values may be specified.

6.4.2.1 Plot a graph of EPS versus mean pixel value PV<sub>mean</sub> as a function as illustrated in Fig. 6.

6.4.2.2 Use the EPS versus PV graph as presented in Fig. 6 for the specific characterization of the CR system to determine the minimum pixel value that provides the desired EPS for the performance level as specified in Table 4.

6.4.2.3 Pixel values and EPS values shall be determined without the use of any digital filtering. Some scanner systems may provide degraded EPS values at very high pixel values and low gain. In the event that this occurs, a maximum pixel value (PV<sub>max</sub>) shall be specified.

6.4.2.4 When establishing minimum pixel values using this method, the specific scanner and its parameters used as well as the specific imaging plate type used shall be recorded for this characterization.

6.4.2.5 The maximum EPS values for specification of PV<sub>min</sub> and PV<sub>max</sub> (if required) for performance Special to Level III are provided in Table 4.

NOTE 6—Minimum SNR<sub>N</sub> performance levels are one of the three basic preconditions for satisfying image quality. The IQI sensitivity improves (smaller EPS) with (1) higher SNR or SNR<sub>N</sub> (higher radiation intensity and exposure time), (2) higher attenuation coefficients (reduced radiation energy), and (3) better (lower values) basic spatial resolution. All these three parameters are relevant for sufficient image quality.

NOTE 7—The classical quality assurance procedure in film radiography is based on the measurement of the film density, optical density of films. Exposed films are accepted only if they have achieved a minimum optical density. A similar procedure can be applied in CR. Each CR system (or any digital imaging system) provides pixel values of each picture element (pixel). The pixels in the region of interest (RoI) that are to be evaluated, evaluated should exceed a minimum pixel value, in a similar way as minimum optical density in film radiography. Single outliers as e.g. as, for example, indications of dust indications may not be evaluated. This minimum pixel value is the reference minimum pixel value PV<sub>minx</sub> as determined in 6.4. This procedure permits basic quality assurance in CR in relation to contrast sensitivity.

## 6.5 Determination of Interpolated Basic Spatial Detector Resolution of CR Systems

### 6.5.1 Duplex-Wire Method

6.5.1.1 The test object to measure the  $iSR_{b,detector}$  is the duplex-wire gagegauge corresponding to Practice E2002. The exposure shall be performed in a distance of 1 m (39 in.) or greater using an X-ray tube with a focal spot size ≤ 1 mm. Focal spot size and focus detector distance shall be selected for a geometric unsharpness of less than 5 % of the total measured unsharpness. The duplex-wire gagegauge shall be positioned directly on the cassette with the IP and lead-screen, metal screens. The measurement shall be performed perpendicular and parallel to the scanning direction of the laser beam. This requires two exposures with one gauge or one exposure with two gauges. The duplex-wire gagegauge shall be used in an angle of about 5° to the scanning direction of the laser beam and about 5° to the perpendicular direction.