



Designation: **C1629/C1629M—19 C1629/C1629M – 23**

Standard Classification for Abuse-Resistant Nondecorated Interior Gypsum Panel Products and Fiber-Reinforced Cement Panels¹

This standard is issued under the fixed designation C1629/C1629M; the number immediately following the designation indicates the year of original adoption or, in the case of revision, the year of last revision. A number in parentheses indicates the year of last reapproval. A superscript epsilon (ϵ) indicates an editorial change since the last revision or reapproval.

1. Scope*Scope

1.1 This standard establishes classifications of abuse resistance based on the abrasion resistance and impact resistance performance of nondecorated interior gypsum panel products and fiber-reinforced cement panels (abuse resistant wall panels).

1.1.1 This standard is a method of classifying gypsum panel product performance and is not intended to classify systems for abuse resistance.

1.2 The values stated in inch-pound and SI (metric) units are to be regarded separately as standard. Within the text, the SI units are shown in brackets. The values stated in each system shall be used independent of the other. Values from the two systems shall not be combined.

1.3 *This standard does not purport to address all of the safety concerns, if any, associated with its use. It is the responsibility of the user of this standard to establish appropriate safety, health, and environmental practices and determine the applicability of regulatory limitations prior to use.*

1.4 *This international standard was developed in accordance with internationally recognized principles on standardization established in the Decision on Principles for the Development of International Standards, Guides and Recommendations issued by the World Trade Organization Technical Barriers to Trade (TBT) Committee.*

2. Referenced Documents

2.1 ASTM Standards:²

[C11 Terminology Relating to Gypsum and Related Building Materials and Systems](#)

[C473 Test Methods for Physical Testing of Gypsum Panel Products](#)

[C840 Specification for Application and Finishing of Gypsum Board](#)

[C1154 Terminology for Non-Asbestos Fiber-Reinforced Cement Products](#)

[D1517 Terminology Relating to Leather](#)

[D4977/D4977M Test Method for Granule Adhesion to Mineral-Surfaced Roofing by Abrasion](#)

[D5420 Test Method for Impact Resistance of Flat, Rigid Plastic Specimen by Means of a Striker Impacted by a Falling Weight \(Gardner Impact\)](#)

2.2 ISO Document:

[ISO 6707-1 Building and Civil Engineering—Vocabulary—Part 1: General Terms](#)

2.3 Federal Specification:

[A-A-50197A Thread, Linen](#)

¹ This classification is under the jurisdiction of ASTM Committee C11 on Gypsum and Related Building Materials and Systems and is the direct responsibility of Subcommittee C11.01 on Specifications and Test Methods for Gypsum Products.

Current edition approved June 1, 2019; June 1, 2023, Published June 2019; August 2023. Originally approved in 2005. Last previous edition approved in 2018 as C1629/C1629M—18a; C1629/C1629M – 19. DOI: [10.1520/C1629-C1629M-19](#); [10.1520/C1629-C1629M-23](#).

² For referenced ASTM standards, visit the ASTM website, [www.astm.org](#), or contact ASTM Customer Service at [service@astm.org](#). For *Annual Book of ASTM Standards* volume information, refer to the standard's Document Summary page on the ASTM website.

***A Summary of Changes section appears at the end of this standard**

2.4 *Voluntary Product Standard:*
PS20 American Softwood Lumber Standard

3. Terminology

3.1 Definitions of terms shall be in accordance with Terminologies **C11** and **C1154**.

3.2 *Definitions of Terms Specific to This Standard:*

3.2.1 *failure (hard body impact), n*—test result constituted by the penetration or deformation of the wall cavity by the impact head establishing a residual deflection of the panel exceeding the nominal thickness of the test panel.

3.2.2 *structural failure (soft body impact), n*—a test result constituted by the penetration or deformation of the wall cavity by the soft body impact bag establishing a residual deflection of any area on the test panel that exceeds the nominal thickness of the test panel.

3.2.2.1 *deformation, n*—change of shape or dimension or both. **ISO 6707-1**

3.2.2.2 *surface damage, n*—pulverization of the core of the test panel at the point of impact, which is evidenced by cracking, creasing, or other visible damage short of failure as defined in **3.2.2**.

3.2.3 *residual deflection, n*—permanent deformation of a building element, component, or structure after removal of applied force.

3.2.3.1 *Discussion*—

Also called permanent set or residual deformation.

4. Significance and Use

4.1 Each abuse/impact property of abuse resistant wall panels is divided into three classification levels. The three levels of classification are: Level I, Level II, and Level III, with Level I representing the lowest rating for any given property. The test methods specified are utilized to establish the abuse-resistance classification of an abuse resistant wall panel. Each classification level requires a minimum overall specified performance. Any classified abuse resistant wall panel can be used at a classification level which is rated lower than the highest level qualified.

5. Basis of Classification

5.1 Abuse resistant wall panels are classified into one of three levels of abuse resistance based on minimum performance when tested in accordance with test methods that evaluate surface abrasion, indentation, soft body impact, and hard body impact as specified in **6.1** through **6.4**.

5.2 Minimum requirements for each level are as shown in **Tables 1-4**.

**TABLE 1 Performance Requirements
 Surface Abrasion Resistance**

Classification Level	Abraded Depth Maximum in. [mm]
1	0.126 [3.2]
2	0.059 [1.5]
3	0.010 [0.3]

**TABLE 2 Performance Requirements
 Indentation Resistance**

Classification Level	Indentation Maximum in. [mm]
1	0.150 [3.8]
2	0.100 [2.5]
3	0.050 [1.3]



**TABLE 3 Performance Requirements
Soft Body Impact Test**

Classification Level	Soft Body Minimum ft·lbf [J]
1	90 [122]
2	195 [265]
3	300 [408]

**TABLE 4 Performance Requirements
Hard Body Impact**

Classification Level	Hard Body Minimum ft·lbf [J]
1	50 [68]
2	100 [136]
3	150 [204]

6. Test Methods

6.1 *Surface Abrasion Test*—This test is conducted in accordance with Test Method **D4977/D4977M** using a total load of ~~25.0 lb~~ **25.0 lb** [11.3 kg]. The specimen is conditioned to constant weight at ~~70°F [21°C]~~ **70°F** [21 °C] and 50 % relative humidity and subjected to 50 abrasion cycles. The abrasive motion on the specimen creates measurable surface wear or indentation which is measured to determine the level of surface abrasion resistance.

NOTE 1—It is especially important to prepare the apparatus and condition the brush as specified in Test Method **D4977/D4977M**.

6.2 *Indentation Test*—This test, conducted in accordance with Test Method **D5420** (Gardner Impact), utilizes procedure GC, with a ~~7/8-in.~~ **7/8-in.** [15.9 mm] hemispherical head and a ~~72 in.·lbf~~ **72 in.·lbf** [12.6 J] impact energy. The depth of the indentation is measured to determine the level of indentation resistance.

6.3 *Soft Body Impact Test*—This test is conducted in accordance with the method described in **Annex A2**.

6.4 *Hard Body Impact Test*—This test is conducted in accordance with the method described in **Annex A1** or with another apparatus equipped with an equivalent impact head that is capable of delivering equivalent impact loads.

ANNEXES

(Mandatory Information)

A1. HARD BODY IMPACT TEST

A1.1 Scope

A1.1.1 The hard body impact test measures resistance to penetration of a wall panel when impacted by a rigid body. Failure in the hard body impact test is achieved when the impacting head completely penetrates through the test panel, or the depth of the indentation exceeds the thickness of the product being tested when measured from the face side following impact, or both.

A1.2 Summary of Test Method

A1.2.1 A nominal 2 × 2 ft [~~610 × 610 mm~~] by 2 ft [610 by 610 mm] specimen is mounted to the apparatus frame. A ramming arm impactor strikes the wall specimen while swinging in an arc. The impactor is dropped from a fixed height to impart specific design energy to the wall specimen. Weights are progressively added to the impactor to increase the design impact energy until specimen failure occurs. For each impact, a new test specimen is used.

A1.3 Significance and Use

A1.3.1 The test method measures relative performance of interior wall panel materials. Although the test panel is mounted on framing and tested vertically as a wall assembly, the impact damage is normally limited to a small area. The method is not intended to evaluate the performance of studs used in wall construction.

A1.4 Apparatus

A1.4.1 The apparatus consists of a rigid frame with a ramming arm pinned to swing in an arc. See **Figs. A1.1 and A1.2**. The frame is constructed of 14 ga, 1 5/8 × 1 5/8 in. [~~41 × 41 mm~~][41 by 41 mm] B-Line B24 Regular Framing Channels.

TABLE A1.1 Weight (Mass) Schedule for the Components of the Ramming Arm Impactor

Component	Weight	Mass
	lb, ±0.5 %	kg, ±0.5 %
Structural Steel Tubing (square cross-section)	8.10	3.67
Steel Plate Pivot Arm	1.10	0.50
Front Square Steel Plate (end plate attached to the front of the structural steel tubing)	0.90	0.41
Rear Square Steel Plate (end plate attached to the back of the structural steel tubing)	0.90	0.41
Cylindrical Steel Impact Head	1.90	0.86
Steel Round Bar (Weight Bar)	2.60	1.18
Bottom Rectangular Steel Plate (attached to the bottom of the structural steel tubing)	4.50	2.04

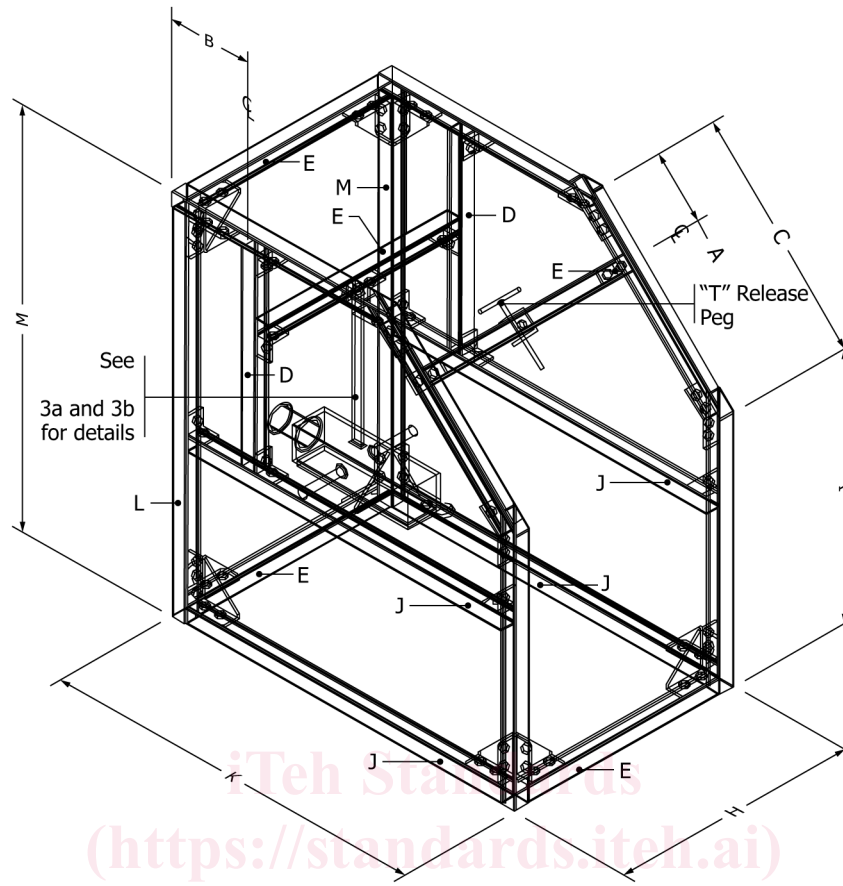

	in.	mm		in.	mm
A	6 ¹ / ₁₆	154.0	I	26 ⁵ / ₁₆	668.3
B	8 ⁵ / ₁₆	211.1	J	34 ¹ / ₄	870.0
C	20 ⁵ / ₁₆	515.9	K	37 ¹ / ₂	952.5
D	20 ⁹ / ₁₆	522.3	L	39 ¹ / ₁₆	992.2
E	20 ³ / ₄	527.1	M	40 ¹¹ / ₁₆	1033.5
H	24	609.6			

NOTE 1—All framing members shall be B-Line B24 Regular Framing Channels cut to the specified dimensions in this sketch. These channels are 14 gauge and have an outside dimension of 1⁵/₈ ×by 1⁵/₈ in. [41 ×by 41 mm].

FIG. A1.1 Axonometric of Hard Body Apparatus Framing Members (not to scale)

A1.4.1.1 The dimensions and details of the ramming arm impactor are shown in Fig. A1.3. The ramming arm impactor consists of a cylindrical steel impact head (made by milling a round steel bar), a structural steel tubing with square cross-section, two square steel plates (front and rear end plates of the structural steel tubing), a steel plate pivot arm, a round steel bar (to add weights), and a rectangular steel plate attached to the bottom of the structural steel tubing. The total weight of the components of the ramming arm impactor is 20.0 lb [9.07 kg] ± 0.5 %, as shown in Table A1.1. The center of mass of the ramming arm impactor coincides with the location of the steel round bar (that is, the weight bar). Additional weights are attached to the weight bar to increase the impacting energy.

A1.4.1.2 The ramming arm impactor shall have a suitable mechanism to secure it at the top of the swing. An example of such a mechanism is a small eyebolt attached to the back of the impactor. When released from the top of the swing, the drop height of the center of mass of the ramming arm impactor shall be 12 in. [305 mm].

A1.4.1.3 The ramming arm is located such that the face of the impactor head, when hanging free at the bottom of the arc, is in the same plane as the surface of the test specimen so that, when dropped, the impactor head strikes the surface of the specimen at the bottom of the arc.

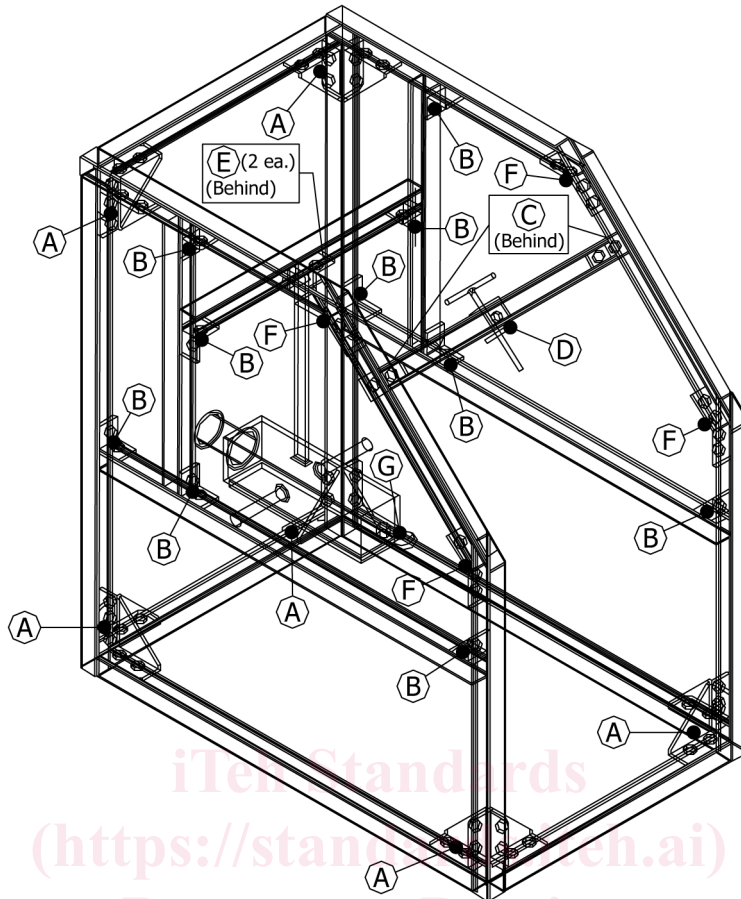

Fastener Schedule

- A B-Line Universal 90° Shelf Bracket B844
- B B-Line Two Hole 90° Corner Angle B230
- C B-Line Two Hole Flat Splice Plate
- D B-Line Beam Clamp B593 Clevis Swivel
- E Unistrut 90° Fitting P6281
- F B-Line Four Hole Open 45° Angle Fitting B248
- G Threaded steel eyebolts with a 1/2 in. [12.5 mm] threaded leg 3 in. [75 mm] long, and an eye interior diameter of 3/16 in. [5 mm]

NOTE 1—Use B-Line Hex Head Cap Screws HHCS 1/2 ×by 1 1/4 in. [12.7 ×by 31.8 mm], B-Line Flat Washers FW 1/2 in. [12.5 mm], and B-Line N225 Spring Nuts to secure all fasteners to framing members.

FIG. A1.2 Axonometric of Hard Body Apparatus Fasteners (not to scale)

A1.5 Test Specimen

A1.5.1 The support for the test specimen shall be constructed by attaching a 2 ×by 2 ft [610 ×by 610 mm] specimen of the interior wall panel material to a frame of 3 5/8 in. [92 mm] deep 30 mil [0.0296 in.] [0.752 mm] minimum thickness steel studs with Type S-12 bugle head screws spaced 8 in. [200 mm] o.c. as shown in Fig. A1.4. The length of the screws shall be 1 1/4 in. [32 mm] for panels up to 5/8 in. [15.9 mm] in thickness. For panels with thickness greater than 5/8 in. [15.9 mm], the length of the screws shall be not less than 5/8 in. [16 mm] longer than the panel thickness.

A1.6 Preparation of Apparatus

A1.6.1 The apparatus shall be securely anchored to a level floor to prevent sliding or rocking of the apparatus during impact.

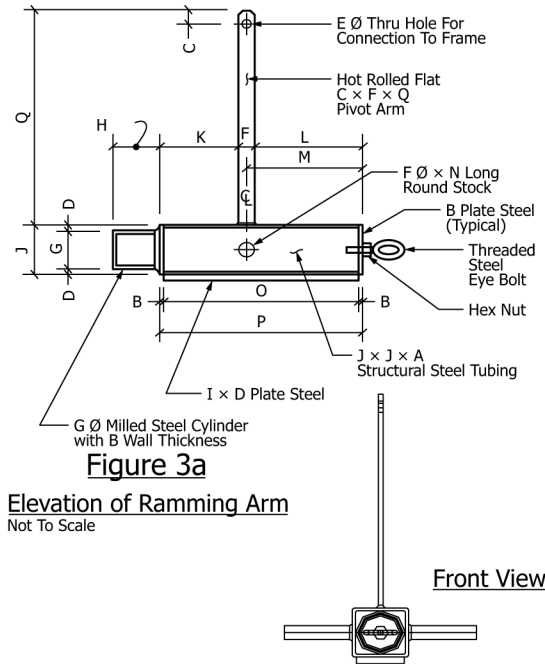

Note:
A Hole Must Be Drilled In The Structural Tubing To Accept The FØ Round Stock. A Hole Must Also Be Drilled In The Back End Plate To Accept The Steel Eye Bolt.

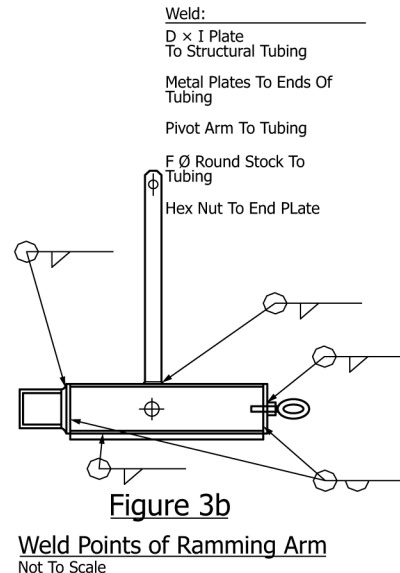

	in.	mm		in.	mm
A	3/16	4.8	J	3 1/2	88.9
B	1/4	6.4	K	4 7/8	123.8
C	5/16	7.9	L	6 3/4	171.5
D	7/16	11.1	M	7 1/4	184.2
E	5/8	15.9	N	12	304.8
F	1	25.4	O	12 1/8	308.0
G	2 3/4	69.9	P	12 9/8	320.7
H	2 15/16	74.6	Q	15 1/4	387.4

FIG. A1.3 Ramming Arm

ASTM C1629/C1629M-23

<https://standards.iteh.ai/catalog/standards/sist/7cf8f315-2db5-4982-b38d-a643ebf1eaae/astm-c1629-c1629m-23>

A1.7 Procedure

A1.7.1 The support for the test specimen shall be securely clamped to the face of the apparatus so that the surface of the test specimen is in the same plane as the face of the impact head.

A1.7.1.1 A new test specimen shall be used for each impact.

A1.7.2 The ramming arm is raised to the top of the arc and secured with a pin.

A1.7.3 The pin is removed, allowing the arm to swing freely and strike the test specimen.

A1.7.4 A new test specimen is mounted to the support and the weight on the impactor is increased by adding 2.5 lb [1.1 kg] to the weight bar and the test repeated.

A1.7.5 The test shall be performed by incrementally increasing the barbell free weights on the impactor until a failure impact energy is achieved.