



Designation: F608 – 22

Standard Test Method for Evaluation of Carpet Embedded Dirt Removal Effectiveness of Household/Commercial Vacuum Cleaners¹

This standard is issued under the fixed designation F608; the number immediately following the designation indicates the year of original adoption or, in the case of revision, the year of last revision. A number in parentheses indicates the year of last reapproval. A superscript epsilon (ϵ) indicates an editorial change since the last revision or reapproval.

1. Scope

1.1 This test method covers only a laboratory test for determining the relative carpet dirt removal effectiveness of household/commercial vacuum cleaners when tested under specified conditions.

1.2 This test method is applicable to household/commercial types of upright, canister, and combination cleaners.

1.3 The test method applies to embedded dirt removal from carpets, not the removal of surface litter and debris.

1.4 The values stated in inch-pound units are to be regarded as standard. The values given in parentheses are mathematical conversions to SI units that are provided for information only and are not considered standard.

1.5 *This standard does not purport to address all of the safety concerns, if any, associated with its use. It is the responsibility of the user of this standard to establish appropriate safety, health, and environmental practices and determine the applicability of regulatory limitations prior to use.*

1.6 *This international standard was developed in accordance with internationally recognized principles on standardization established in the Decision on Principles for the Development of International Standards, Guides and Recommendations issued by the World Trade Organization Technical Barriers to Trade (TBT) Committee.*

2. Referenced Documents

2.1 *ASTM Standards:*²

[C136/C136M Test Method for Sieve Analysis of Fine and Coarse Aggregates](#)

[E11 Specification for Woven Wire Test Sieve Cloth and Test Sieves](#)

[E177 Practice for Use of the Terms Precision and Bias in](#)

[ASTM Test Methods](#)

[E691 Practice for Conducting an Interlaboratory Study to Determine the Precision of a Test Method](#)

[F655 Specification for Test Carpets and Pads for Vacuum Cleaner Testing \(Withdrawn 2022\)](#)³

[F884 Test Method for Motor Life Evaluation of a Built-In \(Central Vacuum\) Vacuum Cleaner](#)

[F922 Test Method for Motor Life Evaluation of an Electric Motorized Nozzle](#)

[F1038 Test Method for Motor Life Evaluation of a Canister, Hand-held, Stick, and Utility Type Vacuum Cleaner Without a Driven Agitator](#)

[F1334 Test Method for Determining A-Weighted Sound Power Level of Vacuum Cleaners](#)

[F1409 Test Method for Straight Line Movement of Vacuum Cleaners While Cleaning Carpets](#)

[F2608 Test Method for Determining the Change in Room Air Particulate Counts as a Result of the Vacuum Cleaning Process](#)

[F2756 Test Method for Determining Energy Consumption of Vacuum Cleaners](#)

3. Terminology

3.1 *Definitions:*

3.1.1 *model, n*—the designation of a group of vacuum cleaners having identical mechanical and electrical construction with only cosmetic or nonfunctional differences.

3.1.2 *population, n*—the total of all units of a particular model vacuum cleaner being tested.

3.1.3 *repeatability limit, r*—the value below which the absolute difference between two individual test results obtained under repeatability condition may be expected to occur with a probability of approximately 0.95 (95 %).

3.1.4 *repeatability standard deviation, S_r*—the standard deviation of test results obtained under repeatability conditions.

3.1.5 *reproducibility limit, R*—the value below which the absolute difference between two test results obtained under reproducibility conditions may be expected to occur with a probability of approximately 0.95 (95 %).

³ The last approved version of this historical standard is referenced on www.astm.org.

¹ This test method is under the jurisdiction of ASTM Committee F11 on Vacuum Cleaners and is the direct responsibility of Subcommittee F11.21 on Cleanability.

Current edition approved Nov. 1, 2022. Published August 2023. Originally approved in 1979. Last previous edition approved in 2018 as F608 – 18. DOI: 10.1520/F0608-22.

² For referenced ASTM standards, visit the ASTM website, www.astm.org, or contact ASTM Customer Service at service@astm.org. For *Annual Book of ASTM Standards* volume information, refer to the standard's Document Summary page on the ASTM website.

3.1.6 *reproducibility standard deviation, S_R* —the standard deviation of test results obtained under reproducibility conditions.

3.1.7 *sample, n* —a group of vacuum cleaners taken from a large collection of vacuum cleaners of one particular model which serves to provide information that may be used as a basis for making a decision concerning the larger collection.

3.1.8 *test run, n* —the definitive procedure that produces a singular measured result.

3.1.9 *unit, n* —a single vacuum cleaner of the model being tested.

4. Significance and Use

4.1 This test method provides an indication of the capability of the vacuum cleaner to remove embedded dirt from carpeting. This test method is based upon results of home cleaning tests so that, in most cases, a reasonable correlation exists between home and laboratory results. The amount of dirt picked up in the laboratory test may not be the same as in the home; however, it will show that, in most cases, a vacuum cleaner that performs well in the laboratory will perform well in a home. Laboratory results may differ due to variations in the homes, carpets, dirt, and other factors (see Section 6).

4.2 In order to provide a uniform basis for measuring the performance described in 1.1, standardized test carpets and a standardized test dirt are employed in this procedure.

5. Apparatus

5.1 *Weighing Scale for Weighing Carpets*, accurate to 0.035 oz (1 g) and having a weighing capacity of at least 15 lb (6.82 kg).

5.2 *Weighing Scale (for Weighing Test Dirt and Dirt Container)*, (see 9.2.2.1(2)), accurate to 0.0035 oz (0.1 g) and having a weighing capacity of at least 1.1 lb (500 g).⁴

5.3 *Stopwatch*, with a second hand or other type of equipment capable of establishing the specified rate of movement and total cycle time.

5.4 *Voltmeter*, to measure input volts to the vacuum cleaner, to provide measurements accurate to within $\pm 1\%$.

5.5 *Voltage-Regulator System*, to control the input voltage to the vacuum cleaner. The regulator shall be capable of maintaining the vacuum cleaner's rated voltage $\pm 1\%$ and rated frequency having a wave form that is essentially sinusoidal with 3 % maximum harmonic distortion for the duration of the test.

5.6 *Dirt Embedment Tool*, with the roller locked (see Fig. 3).

5.7 *Dirt Dispenser*—Dispensing system that provides the operator with a method to distribute the test dirt *uniformly* on the carpet test area.

⁴ The Mettler-Toledo Model PM 2000, available from Mettler-Toledo, Inc. Box 71, Hightstown, NJ 08520, the OHAUS Model GT-8000 available from OHAUS, Inc. Florham Park, NJ, or equivalent, have been found suitable for this purpose. (It is recommended that the scale read directly in grams.) If you are aware of alternative suppliers, please provide this information to ASTM International Headquarters. Your comments will receive careful consideration at a meeting of the responsible technical committee,¹ which you may attend.

5.8 *Carpet-Conditioning Equipment*, to support the test carpet during new carpet conditioning and the removal of residual dirt from the test carpet before each test run (Fig. 4).

5.9 *Rotating Agitator Conditioning Vacuum Cleaner/Equipment*, for conditioning new test carpets and removing residual dirt from the test carpet before each test run. This cannot be the unit being tested.

NOTE 1—Automated methods for spreading the test dirt, embedding the test dirt, and cleaning and reconditioning the test carpets are acceptable if they do not change the results of this test method.

5.10 *Temperature and Humidity Indicators*, to provide temperature measurements accurate to within $\pm 1^\circ\text{F}$ ($\pm \frac{1}{2}^\circ\text{C}$) and humidity measurements accurate to within 2 % relative humidity.

5.11 *Supporting Surface*—A flat surface consisting of a piece of $\frac{3}{4}$ -in. (19-mm) thick exterior grade plywood with the “A” surface upward to support the test carpet and pad. If necessary, the four corners (only) of the test carpet and pad may be fastened to the supporting surface by any acceptable means.

5.12 *Rotating Agitator Reference Vacuum Cleaner*, one, for calibrating test carpets (see 9.3).

5.13 *Straight-Air Canister Reference Vacuum Cleaner*, one, for calibrating test carpets (see 9.3).

6. Materials

6.1 Standard carpets conforming to Specification F655,

6.2 Standard carpet padding conforming to Specification F655,

6.3 Test dirt (see Annex A1),

6.3.1 Silica sand (see Annex A1), and

6.3.2 Talc (see Annex A1).

6.4 All products being tested in a comparison test must be tested using materials from identical production lots or batches. Verify that a sufficient quantity of all materials from a single lot/batch is on hand prior to starting the test program.

7. Sampling

7.1 A minimum of three units of the same model vacuum cleaner selected at random in accordance with good statistical practice shall constitute the population sample.

7.1.1 To determine the best estimate of cleaning ability effectiveness for the population of the vacuum cleaner model being tested, the arithmetic mean of the cleaning ability rating of the sample from the population shall be established by testing it to a 90 % confidence level within $\pm 5\%$ of the mean value of the cleaning ability rating.

7.1.2 Annex A3 provides a procedural example for determining the 90 % confidence level and when the sample size shall be increased.

NOTE 2—See Annex A3 for method of determining 90 % confidence level for both individual carpets and geometric mean.

8. Conditioning

8.1 *Test Room*—Maintain the test room in which all conditioning and vacuum cleaner testing is performed at $70^\circ\text{F} \pm 5^\circ\text{F}$ ($21^\circ\text{C} \pm 3^\circ\text{C}$) and 45 % to 55 % relative humidity.

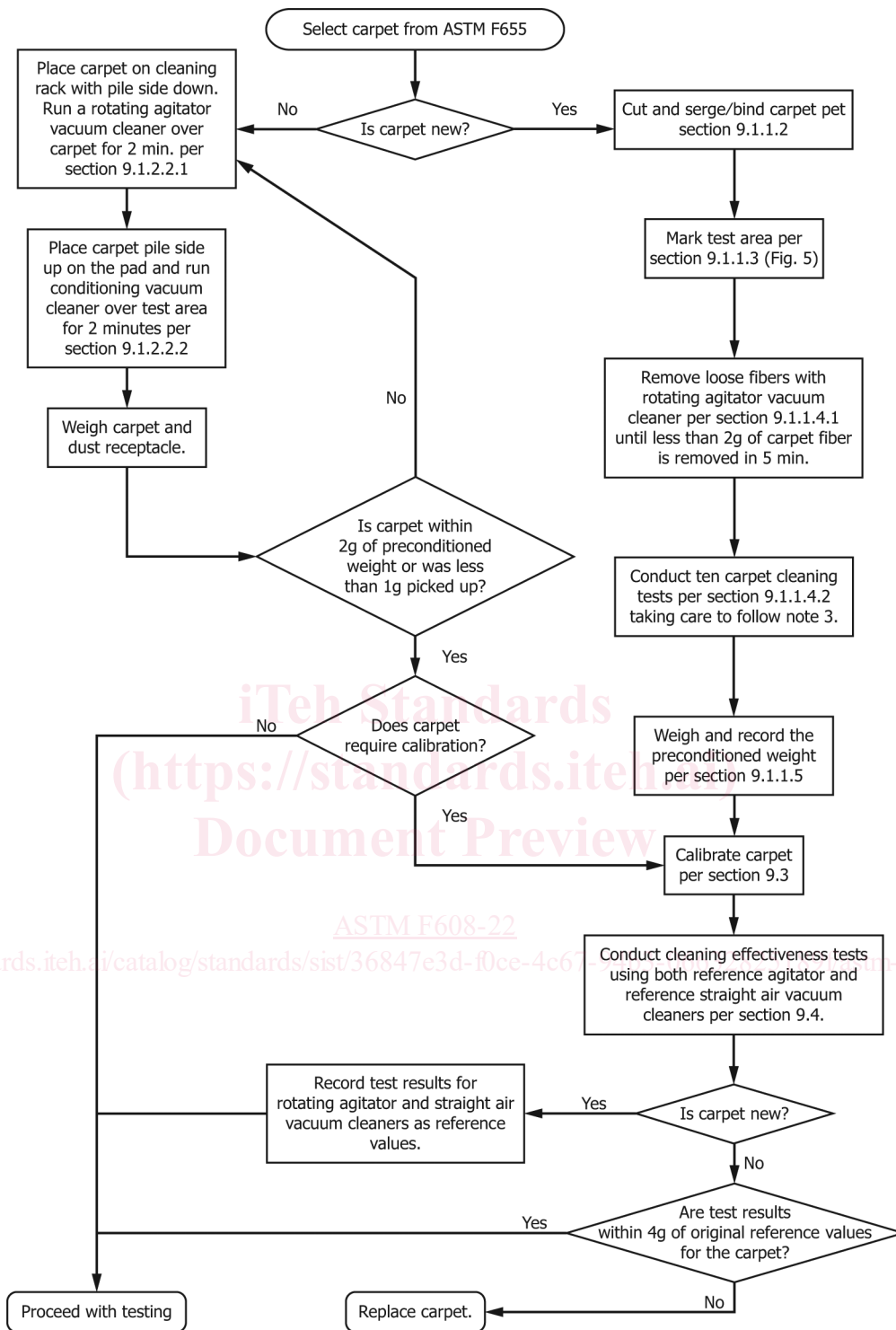

FIG. 1 Carpet Conditioning/Calibration Procedure

8.2 All components involved in the test shall remain and be exposed in the controlled environment for at least 16 h prior to the start of the test.

9. Procedure

9.1 Test Carpet Preparation:

9.1.1 Preconditioning New Test Carpet Samples:

9.1.1.1 New test carpets shall conform to Specification F655.

9.1.1.2 Cut a sample of each test carpet to a size of 27 in. by 72 in. (690 mm by 1830 mm) minimum. If the warp direction or “lay” of the carpet can be determined, it shall be in the 72 in. direction as indicated in Fig. 5. Carpets shall be bound or serged on all sides.

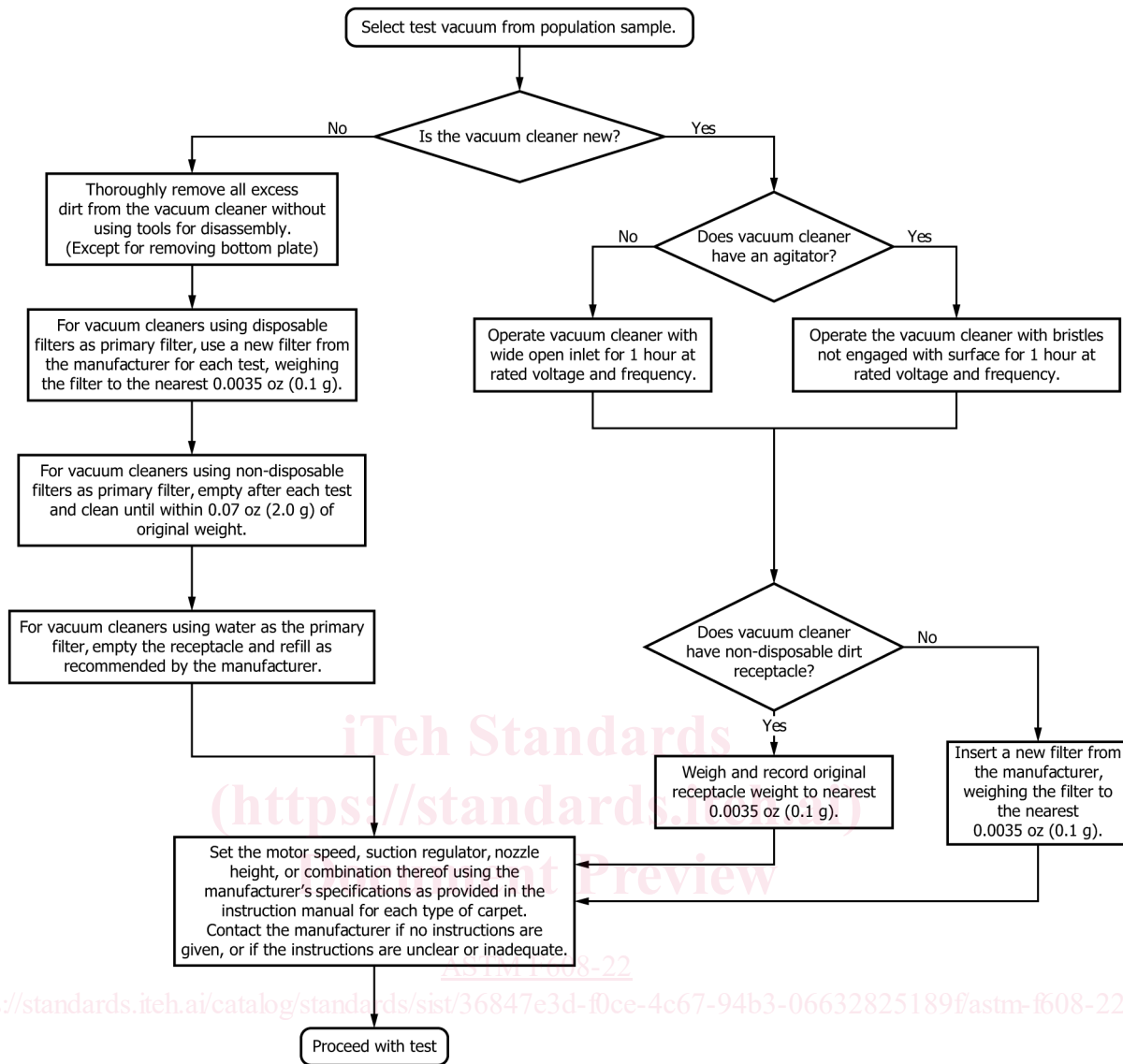

FIG. 2 Vacuum Cleaner Conditioning Procedure

9.1.1.3 Mark the test area on each carpet as indicated in Fig. 5.

9.1.1.4 Precondition New Test Carpet Samples:

(1) Precondition the entire area of the carpet by cleaning with the rotating agitator conditioning vacuum cleaner. Continue the operation until less than 0.07 oz (2 g) of carpet fiber is picked up in 5 min.

(2) Run ten carpet-embedded dirt removal effectiveness test runs in accordance with 9.4.2 – 9.4.18.

NOTE 3—Recondition the new test carpet following each preconditioning test run. It is not necessary, however, to meet the requirements set forth in 9.1.2.1 with respect to the preconditioned weight.

9.1.1.5 Weigh and record the preconditioned weight of the carpet.

9.1.1.6 Run a test carpet calibration in accordance with 9.3.

9.1.2 Reconditioning Used Test Carpet Samples:

9.1.2.1 Initial Daily Reconditioned Weight—At the beginning of each day, it is necessary to remove any dirt that may

have settled on the carpet surface and stabilize the moisture content of the carpet. Clean the carpet with a rotating agitator conditioning vacuum cleaner until its weight does not exceed the initial reconditioned weight from the previous day of testing by more than 0.07 oz (2 g) or less than 0.035 oz (1 g) is picked up by the conditioning vacuum cleaner using the procedure in 9.1.2.3.

9.1.2.2 Following each test run, it is necessary to remove the residual dirt and stabilize the moisture content of the carpet. Clean the carpet with a rotating agitator conditioning vacuum cleaner until its weight does not exceed the initial daily reconditioned weight requirement of 9.1.2.1 by more than 0.07 oz (2 g) or less than 0.035 oz (1 g) is picked up by the conditioning vacuum cleaner using the following procedure.

9.1.2.3 Procedure:

(1) Place the carpet on the carpet cleaning rack (Fig. 4) with the pile side down. Run the rotating agitator conditioning vacuum cleaner over the carpet for 2 min, concentrating on the

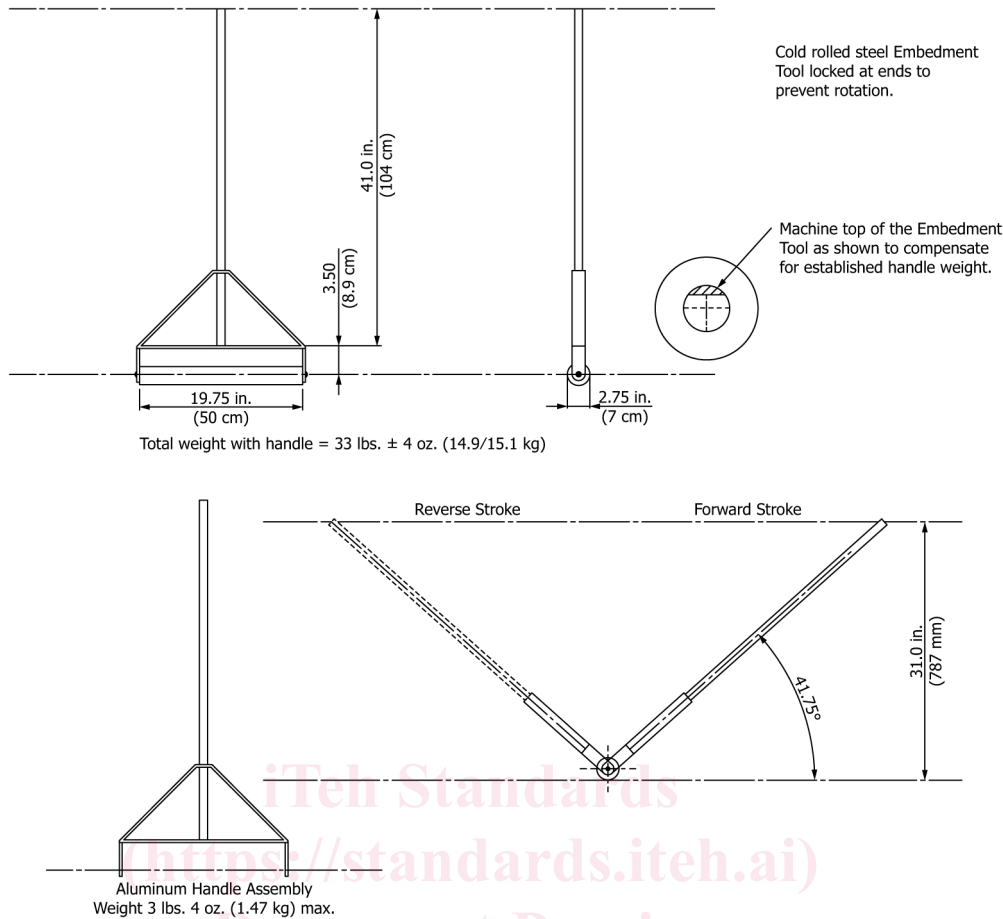

FIG. 3 Dirt Embedment Tool

test area at 21.6 in./s ± 0.8 in./s (0.55 m/s ± 0.02 m/s); then run the rotating agitator conditioning vacuum cleaner thoroughly over the entire carpet area at least one time.

(2) Place the carpet (pile side up) on the pad, on the plywood supporting surface, and clean it with the rotating agitator conditioning vacuum cleaner for 2 min, concentrating on the test area; then run the rotating agitator vacuum cleaner thoroughly over the entire area at least one time.

(3) Weigh the carpet.

(4) Keep alternating 9.1.2.3(1) and 9.1.2.3(2), always ending with the pile side up, until the carpet weight meets the requirements of 9.1.2.1 or 9.1.2.2.

(5) Change the disposable primary filter after a maximum of every 4 runs on the conditioning vacuum cleaner or more often if required.

(6) Reconditioning equipment that uses nondisposable filters should have the filter or filters cleaned after every four carpet reconditioning runs or more often, if required.

NOTE 4—A high-cleaning performance rotating agitator vacuum cleaner is recommended for reducing the time to recondition the carpet.

9.1.3 Reconditioning Used Carpet Padding:

9.1.3.1 Clean the carpet padding by shaking weekly or more often, if necessary, to remove any collected dirt.

9.1.3.2 Replace the carpet padding when it has holes, tears, or other signs of wear.

9.2 Preparation of Test Vacuum Cleaners:

9.2.1 New Test Vacuum Cleaners:

9.2.1.1 For a vacuum cleaner that has not been used for any testing, run the vacuum cleaner in at rated voltage ± 1 % and rated frequency with filters in place.

(1) *Preconditioning a Rotating Agitator Type Vacuum Cleaner*—In a stationary position, operate the vacuum cleaner for 1 h with the agitator bristles not engaged on any surface.

(2) *Preconditioning a Straight-Air Type Vacuum Cleaner*—Operate the vacuum cleaner for 1 h with a wide-open inlet (without hose).

9.2.1.2 For vacuum cleaners with non-disposable dirt receptacles, weigh and record the receptacle's original weight and any filters, to the nearest 0.0035 oz (0.1 g).

9.2.2 Used Test Vacuum Cleaners:

9.2.2.1 Recondition a used test vacuum cleaner, prior to each test run, as follows:

(1) Thoroughly remove excess dirt from the vacuum cleaner. Without using tools for disassembly, clean the entire outer surface, brushes, nozzle chamber, ductwork, inside of the chamber surrounding the primary filter, and inside hose and wands. Check the condition of all mechanisms for signs of wear or damage. See Note 5.

(2) For vacuum cleaners using disposable filters as the primary filters, use a new disposable primary filter from the

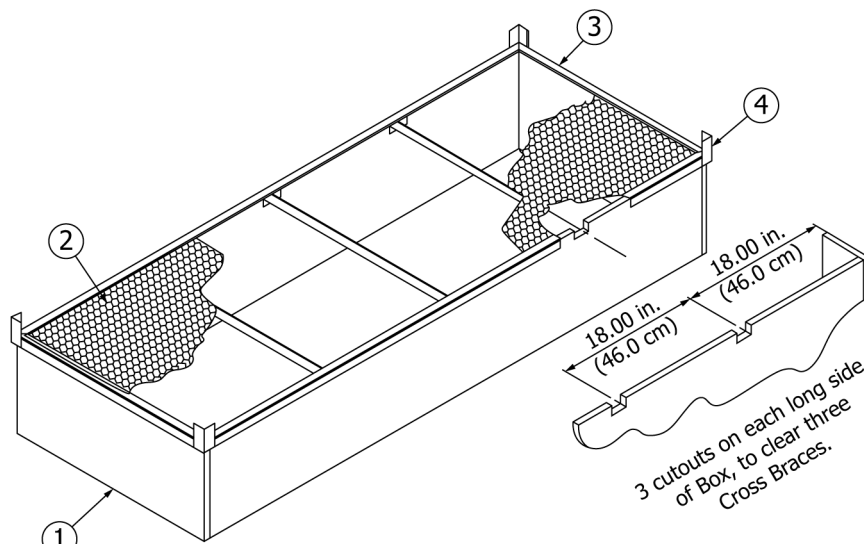

- ①— **Five Sided Box** with open top.
Outside Dimensions, Length -72 in. (183 cm)
Width - 27 in. (69 cm)
Depth - 12 in. (30.5 cm)
Material - Plywood, 3/4 in. (1.9 cm) thick.
Optional - Bottom of box may be sloped downward to center opening to simplify emptying of test dirt accumulation.
- ②— **Flattened Expanded Steel Top Panel**, 0.070 in. (1.8 mm) thick, with "75%open" area, and with diamond shaped openings.

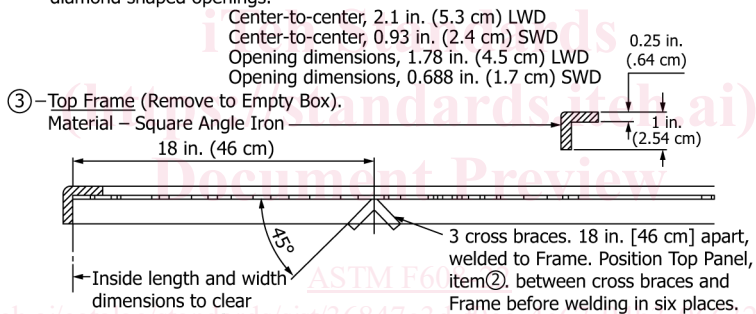

- ③— **Top Frame** (Remove to Empty Box).
Material - Square Angle Iron
18 in. (46 cm)
- ④— **Corner Supports** (four) to position carpet.
Material - Square Angle Iron
3 in. (7.6 cm)
1.25 in. (3.2 cm)
0.125 in. (0.32 cm) radius

FIG. 4 Carpet Cleaning Rack

manufacturer for each test run. Weigh the filter to the nearest 0.0035 oz (0.1 g) and install it as recommended by the vacuum cleaner manufacturer.

(3) For vacuum cleaners using water as the primary filter, empty the receptacle and refill as recommended by the manufacturer.

(4) For vacuum cleaners using non-disposable dirt receptacles, empty in accordance with the manufacturer's instructions after each test run. The dust receptacle and any additional filters removable without the aid of tools shall, prior to each trial, be cleaned according to manufacturer's instructions until its weight is within 0.07 oz (2 g) of its original weight. Weigh the combined receptacle and any integral filters

to the nearest 0.0035 oz (0.1 g) and install as recommended by the vacuum cleaner manufacturer. If it is determined after repeated attempts at cleaning that the dust receptacle cannot be cleaned sufficiently to return it to within 0.07 oz (2 g) of its original weight, but trial results fall within the repeatability limits, the trial is deemed acceptable, and testing may continue.

(5) Clean all secondary filters that are removable without the aid of tools in accordance with manufacturer's instructions until its weight is within 0.07 oz (2 g) of its original weight. Washing of filters is not permitted.

NOTE 5—It is recommended that a replaceable brush drive belt for vacuum cleaner agitators be changed after each four test runs, if

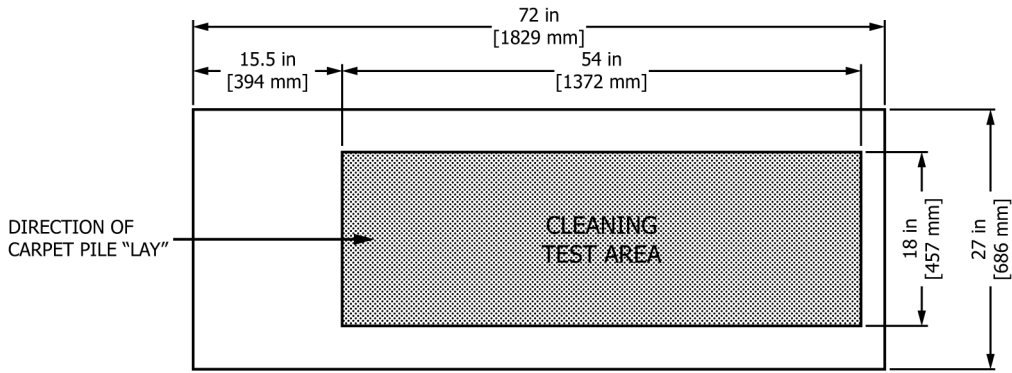

NOTE 1 – Cleaning test area should be positioned as shown. First forward stroke of cleaner is in direction with “lay” of carpet pile.

NOTE 3—Cleaning test area should be positioned as shown. First forward stroke of cleaner is in direction with “lay” of carpet.

NOTE 1—Cleaning test area should be positioned as shown. First forward stroke of cleaner is in direction with “lay” of carpet.

FIG. 5 Test Carpet

considered applicable, using manufacturer’s instructions. Any other maintenance task, such as cleaning the brush belt with distilled water, should only be done in accordance with manufacturer’s recommendations.

9.2.3 Test Vacuum Cleaner Settings:

9.2.3.1 If various settings are provided, set the motor speed setting, suction regulator, nozzle height, or combination thereof using the manufacturer’s specifications as provided in the instruction manual for each type of carpet. Contact the manufacturer if no instructions are given, or if the instructions are unclear or inadequate.

9.2.3.2 All straight line movement (see Test Method F1409), sound power (see Test Method F1334), edge cleaning (see Test Method F2608), energy measurement (see Test Method F2756), and motor life evaluation (see Specification F655 and Test Methods F884, F922, and F1038) tests shall be conducted using the same settings (nozzle, motor speed, suction regulator, etc.) for each specific carpet.

9.2.4 Reference Vacuum Cleaners (Calibration):

9.2.4.1 Use the reference vacuum cleaners only for determining the reference rating of carpets and for the verification of carpet acceptability (see 9.3).

9.2.4.2 Maintain the performance of the reference vacuum cleaners throughout the acceptable life of the carpet (i.e. nozzle suction, bristle extension, motor and agitator speeds, etc.).

9.3 Test Carpet Calibration:

9.3.1 The purpose of calibration is to determine when the test carpet needs to be replaced by establishing a reference rating for each new preconditioned test carpet and to check this rating 50 or fewer test runs.

9.3.2 The reference ratings are determined for each test carpet by the percent pickup using the reference rotating agitator vacuum cleaner and the reference straight-air vacuum cleaner.

9.3.3 The percent pickup is determined by performing a carpet-embedded dirt removal effectiveness test (see 9.4).

9.3.4 When the embedded dirt rating for either reference cleaner varies by 0.14 oz (4 g) from the original reference rating for the carpet, replace the carpet.

9.3.4.1 All products being tested in a comparison test must be tested on the same calibrated carpet panels throughout the test program. If a particular carpet panel is found to no longer be acceptable for testing due to the 0.14 oz (4 g) limit being exceeded during a calibration check, all products tested on that particular carpet panel during the test program must be retested on the new carpet panel to ensure proper comparison.

NOTE 6—Carpet pick up changes over time as the test carpet panel is used due to normal carpet wear. General laboratory practice is to track and record the number of test runs on each carpet panel. It is recommended to estimate, as closely as possible, the number of required test runs on all carpet panels intended to be used prior to starting any test program in order to establish that the selected carpet panels have a sufficient number of test runs left to complete the test program.

9.4 Carpet Embedded Dirt Removal Effectiveness Test:

9.4.1 If preconditioning or reconditioning has been done more than 1 h before a test run, weigh the carpet. If the weight of the carpet exceeds the preconditioned or reconditioned weight by more than 0.07 oz (2 g), clean the carpet with a rotating agitator conditioning vacuum cleaner until these criteria are met.

9.4.2 Position the test carpet on the padding (with “scrim” side of the padding up) on the supporting surface (see 5.11).

9.4.3 The test cleaners and dirt receptacles should be prepared in accordance with 9.2.

9.4.4 Weigh the prepared dirt receptacle (that is, dust bag or other primary filter device) prior to conducting the measurement test run. Record the weight to the nearest 0.0035 oz (0.1 g).

9.4.5 Install the primary filter as explained below.

9.4.5.1 For vacuum cleaners using disposable or non-disposable primary filters, install the primary filter from the manufacturer per their instructions.

9.4.5.2 For vacuum cleaners using water as the primary filter, empty and refill the receptacle as recommended by the vacuum cleaner manufacturer.

9.4.6 Ensure that the vacuum cleaner settings have been made in accordance with 9.2.3.

9.4.7 *Test Dirt Preparation*—Weigh and mix 3.17 oz ± 0.0035 oz (90 g ± 0.1 g) of silica sand and 0.35 oz ± 0.0035 oz (10 g ± 0.1 g) of commercial grade talcum, both conforming to the specifications found in Annex A1.

9.4.7.1 Silica sand shall be sieved to assure conformance to the specification of A1.2. Sieving shall be performed in accordance with Test Method C136/C136M.

9.4.7.2 Bulk mixing and storage of sieved constituents of silica sand is acceptable if assay analysis meets the specification of A1.2.

9.4.7.3 Bulk storage of test dirt mixture (sand plus talc) is not allowed.

9.4.8 Distribute 3.52 oz (100 g) of the test dirt uniformly on the cleaning test area (see Fig. 5), using any convenient spreading method.

9.4.9 Embed the test dirt into the carpet using the dirt embedment tool shown in Fig. 3. Perform the embedding process by using a dragging motion in both directions with the handle held at the angle shown. Drag the dirt embedment tool over the test area exactly 30 strokes, alternating directions forward and back. (A movement in one direction is one “stroke.”) Use a uniform movement to provide a “stroke” time of 2.5 s (a rate of 21.6 in./s ± 0.8 in./s (0.55 m/s ± 0.02 m/s)). The first forward stroke shall be in the direction of the carpet lay. An acceptable laboratory practice shall be used to ensure that the embedment tool shall not fall short of reaching the end boundaries of the test area, and the tool shall cover both side boundaries of the test area at all times.

9.4.10 Clean the embedding tool as needed.

9.4.11 If the vacuum cleaner has not been energized for more than 60 min, energize the cleaner for 2 min at nameplate rated voltage (±1 %) and frequency (±1 Hz) immediately preceding the test sequence of 9.4.12. For vacuum cleaners with dual nameplate voltage ratings, conduct testing at the highest voltage.

9.4.11.1 For a rotating agitator-type vacuum cleaner, place it such that the bristles clear the supporting surface and no loose dirt is picked up.

9.4.11.2 For a straight-air canister vacuum cleaner, operate with the rug tool unrestricted, positioned such that no loose dirt is picked up from the supporting surface.

9.4.12 Immediately following the 2-min “run-in” of 9.4.11, de-energize the vacuum cleaner and place the vacuum cleaner nozzle on the test carpet so that the front edge of the vacuum

cleaner coincides with the line defining the beginning of the test area and the right side of the boundary of the 18-in. test width (see Fig. 6). The forward stroke of the nozzle shall be in the direction of the carpet lay (see Fig. 5).

9.4.12.1 Reasonable efforts shall be made to maintain the handle height at 31.5 in. (0.8 m) during each test run for vacuum cleaners with a pivoting handle.

9.4.12.2 Reasonable efforts shall be made to maintain the vacuum cleaner’s nozzle parallel to the test carpet surface during each test run for vacuum cleaners with non-pivoting handles.

9.4.13 Tilt or lift the nozzle off the carpet, energize the vacuum cleaner, and adjust the voltage to rated voltage ±1 %. Allow the vacuum cleaner to run and expand the filter bag, if one is present.

9.4.14 *Test Cleaning Pattern:*

9.4.14.1 For a rotating agitator-type vacuum cleaner, lower the nozzle onto the carpet before the test area. Again, adjust the voltage to rated voltage ±1 %; then move the nozzle at a rate of 21.6 in./s ± 0.8 in./s (0.55 m/s ± 0.02 m/s) in the test cleaning pattern and motion as specified in Annex A2 during the cleaning cycle. Maintain the nozzle position and settings as specified in 9.2.3 during the cleaning cycle.

9.4.14.2 For a straight-air vacuum cleaner, position the nozzle on the carpet before the test area. Again, adjust the voltage to rated voltage ±1 %; then move the nozzle at a rate of 21.6 in./s ± 0.8 in./s (0.55 m/s ± 0.02 m/s) in the test cleaning patterns and motion as described in Annex A2. Maintain the nozzle position and settings as specified in 9.2.3 during the cleaning cycle.

9.4.14.3 At the end of the last stroke, smoothly tilt or lift the vacuum cleaner nozzle off the carpet and allow the vacuum cleaner to run an additional 10 s to clear the system of test dirt actually picked up but temporarily trapped within it before de-energizing the vacuum cleaner. During the additional run period, the hose used with the canister and combination vacuum cleaners should be flexed to help clear the system.

9.4.15 For vacuum cleaners with removable dirt receptacles, carefully remove the dust receptacle (dust bag or other primary filter device) and weigh it. Record the weight to the nearest 0.0035 oz (0.1 g).

9.4.15.1 For bagless dirt receptacles, remove the dirt receptacle assembly, including whatever filters it contains.

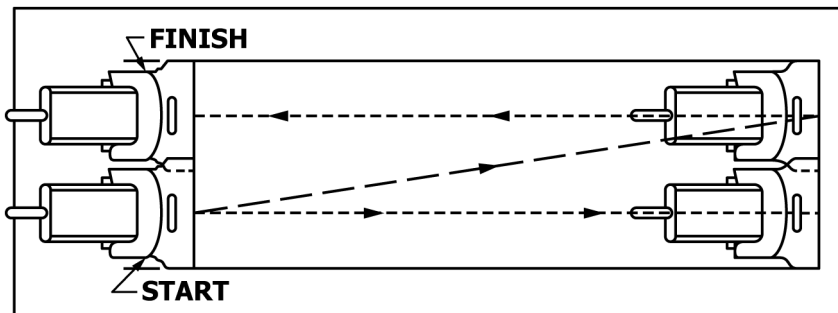

NOTE 1—This shows the nozzle positions for the cleaning pattern when $N=2$. (Refer to Annex A2.)

FIG. 6 Cleaner Nozzle Position at Start and Finish of Test Cleaning Strokes

9.4.16 For vacuum cleaners using water as the primary filter, weigh the carpet to the nearest 0.035 oz (1.0 g).

9.4.17 Determination of the grams picked up for each test run will be done in the following manner:

9.4.17.1 For vacuum cleaners with removable dirt receptacles, subtract the weight of the clean dirt receptacle at the start of test from the weight of the dirt receptacle at the end of the test. Record results to the nearest 0.0035 oz (0.1 g).

9.4.17.2 For vacuum cleaners using constructions or technologies for which weighing a dirt receptacle, filter(s) or filter bag is impractical or does not provide reliable results, add 3.53 oz (100 g) to the weight of the carpet at the start of the test run and subtract the weight of the carpet at the end of the test run. Record results to the nearest 0.035 oz (1 g). If it is necessary to use the procedure in 9.4.17.2 for one vacuum cleaner in a comparison test, the same method must be used for all vacuum cleaners in the comparison.

9.4.18 The percent carpet-embedded dirt removal effectiveness for a single test run of a given vacuum cleaner on a given carpet is the grams recorded in 9.4.17 expressed as a percentage.

9.4.19 Using the same test vacuum cleaner, repeat 9.4.1 – 9.4.18 two additional times for a total of three test runs.

9.4.19.1 If after three tests on the sample, the repeatability limits are not met, and no attributable reason for the outlier data can be determined, the results must be discarded and replaced with three new test runs (see A3.3.3).

NOTE 7—If after the first three tests on a new vacuum cleaner sample, the repeatability limits are not met due to the results of the first test run, the first test run may be discarded and replaced with an additional test run.

NOTE 8—If after three test runs, the repeatability limits are not met for a specific carpet, additional test runs may be conducted only on the particular carpet until the repeatability limits are met. It is not necessary to do additional test runs on all of the carpets. See Annex A4 for an example.

NOTE 9—If the test data is intended to be used for comparing different products of differing manufacture, it is strongly recommended that unless an automated test machine is used, the same operator conducts all testing involved in the comparison to minimize any potential effect different operators may have on the results. Assistance in reconditioning the carpets and unit under test may be provided by additional personnel.

NOTE 10—An attributable cause for an outlier may be physical, such as a broken component, seal, or other item that can be shown to lead to the outlying data, or contamination, such as oil or talc on a drive belt causing excessive slippage. If the test sample is easily repaired with the replacement of the faulty component, or if adequate cleaning restores lost performance, it can be used to continue the testing. If the fault cannot be repaired, the test sample is replaced with a new test sample.

NOTE 11—Whatever the reason of the outlier, it should be recorded in the report section, along with the resolution to the problem.

9.4.20 The percent carpet-embedded dirt removal effectiveness for each individual test vacuum cleaner from the popula-

tion sample for a given carpet is the average of three test runs meeting the repeatability statement in Section 11. See A3.3 for a procedural example and whether further test runs need to be conducted.

9.4.21 The percent carpet-embedded dirt removal effectiveness for each individual vacuum cleaner from the population sample is the geometric mean of the individual carpet values. See Annex A3 for a procedural example on calculating the geometric mean.

9.4.22 A minimum of two additional test sample units of the same model shall be selected in accordance with the sampling statement of Section 7. Repeat 9.4.1 – 9.4.20 for each new test sample unit selected.

9.4.23 The percent carpet-embedded dirt removal effectiveness for the population of the vacuum cleaner model being tested is the arithmetic mean of geometric mean values of the percent carpet-embedded dirt removal effectiveness from a sample of the population meeting the requirements of the sampling statement (Section 7).

10. Report

10.1 For each vacuum cleaner sample from the population being tested, report the following information:

10.1.1 Manufacturer’s name, product name, product model, and serial number.

10.1.2 Type of cleaner; that is, upright, canister, etc.

10.1.3 The average soil removed for each of the standard carpets specified in Specification F655 tested.

10.1.4 The geometric mean of the soil removal from all carpets specified in Specification F655 carpets.

10.2 The overall average(s), standard deviation(s), and 90 % confidence results for all of the population sample tested shall also be reported.

10.3 If the data contains an outlier, as noted in 9.4.19.1, the cause for the outlier, if attributable, and resolution shall be recorded in the report.

11. Precision and Bias

11.1 The following precision statements are based on inter-laboratory tests⁵⁻⁷ involving six laboratories and two test units (one upright vacuum cleaner with agitator and one canister with straight-air floor tool).

⁵ Supporting data have been filed at ASTM International Headquarters and may be obtained by requesting Research Report RR:F11-1010. Contact ASTM Customer Service at service@astm.org.

⁶ Supporting data have been filed at ASTM International Headquarters and may be obtained by requesting Research Report RR:F11-1013. Contact ASTM Customer Service at service@astm.org.

TABLE 1 Repeatability and Reproducibility

Type Carpet	Type Cleaner	Standard Deviation of Repeatability, S_r	Repeatability Limit, r	Standard Deviation of Reproducibility, S_R	Reproducibility Limit, R
Plush	Agitator	1.0	2.8	3.4	9.5
	Straight Air	0.7	2.0	1.8	5.0
Level Loop	Agitator	1.4	3.9	2.6	7.3
	Straight Air	1.3	3.7	6.6	18.5
Freize/Shag	Agitator	0.5	1.5	1.2	3.4
	Straight Air	0.16	0.4	0.4	1.1

11.2 The statistics have been calculated as recommended in Practice **E691**.

11.3 The following statements regarding repeatability limit and reproducibility limit are used as directed in Practice **E177**.

11.4 The standard deviations of repeatability and reproducibility of the measured results have been derived from twelve sets of data, where each of two sets of three test runs have been performed by a single analyst within each of the six laboratories on separate days using the same test unit.

11.5 *Repeatability (Single Operator and Laboratory; Multiday Testing)*—The ability of a single analyst to repeat the test within a single laboratory.

11.5.1 The expected standard deviation of repeatability of the measured results within a laboratory, s_r , has been found to be the respective values listed in **Table 1**.

11.5.2 The 95 % repeatability limit within a laboratory, r , has been found to be the respective values listed in **Table 1**, where $r = 2.8(s_r)$.

11.5.3 With 95 % confidence, it can be stated that within a laboratory a set of measured results derived from testing a unit should be considered suspect if the difference between any two of the three values is greater than the respective value of the repeatability limit, r , listed in **Table 1**.

11.5.4 If the absolute value of the difference of any pair of measured results from three test runs performed within a single laboratory is not equal to or less than the respective repeatability limit listed in **Table 1**, that set of test results shall be considered suspect.

⁷ Supporting data have been filed at ASTM International Headquarters and may be obtained by requesting Research Report RR:F11-1014. Contact ASTM Customer Service at service@astm.org.

11.6 *Reproducibility (Multiday Testing and Single Operator Within Multilaboratories)*—The ability to repeat the test within multiple laboratories.

11.6.1 The expected standard deviation of reproducibility of the average of a set of measured results between multiple laboratories, s_R , has been found to be the respective values listed in **Table 1**.

11.6.2 The 95 % reproducibility limit within a laboratory, R , has been found to be the respective values listed in **Table 1**, where $R = 2.8(s_R)$.

11.6.3 With 95 % confidence, it can be stated that the average of the measured results from a set of three test runs performed in one laboratory, as compared to a second laboratory, should be considered suspect if the difference between those two values is greater than the respective values of the reproducibility limit, R , listed in **Table 1**.

11.6.4 If the absolute value of the difference between the average of the measured results from the two laboratories is not equal to or less than the respective reproducibility limit listed in **Table 1**, the set of results from both laboratories shall be considered suspect.

11.7 *Bias*—No justifiable statement can be made on the bias of the method to evaluate carpet-embedded dirt removal effectiveness of household/commercial vacuum cleaners since the true value of the property cannot be established by an acceptable referee method.

12. Keywords

12.1 dirt removal; vacuum cleaners

ASTM F608-22

<https://standards.iteh.ai/catalog/standards/sist/36847e3d-f0ce-4c67-94b3-06632825189f/astm-f608-22>

ANNEXES

(Mandatory Information)

A1. TEST DIRT

A1.1 *Test Dirt*, 100 g, consisting of the following:

A1.1.1 *Item 1*—90 g of silica sand⁸ in accordance with **A1.2**.

A1.1.2 *Item 2*—10 g of commercial grade talcum in accordance with **A1.3**.

A1.2 Silica sand in the following particle size range and amounts:

Sieve Range, U.S. No.	Particle Size, μm	Amount Used, g
–30/+40	600–425	0.9
–40/+50	425–300	31.5
–50/+70	300–212	41.4
–70/+100	212–150	13.5
–100/+140	150–106	2.7

A1.3 Commercial grade talcum with the following particle size distribution:

Particle Size Range, μm	Distribution by Weight, %
>44	0.5
43.9 to 20	12.5
19.9 to 10	27.0
9.9 to 5	23.0
4.9 to 2	20.0
1.9 to 1	8.0
<0.9	9.0

Note—Talc is used as an inflating agent for the filter bag.

⁸ The sole source of supply of the sand (Wedron No. 540 Unground Silica Sand) known to the committee at this time is The Wedron Silica Co., Customer Service Department, P.O. Box 119, Wedron, IL 60557. (The test dirt must be sieved to ensure conformance with the analysis limits. Use Test Method **C136/C136M**.) If you are aware of alternative suppliers, please provide this information to ASTM International Headquarters. Your comments will receive careful consideration at a meeting of the responsible technical committee,¹ which you may attend.

A2. TEST CLEANING PATTERN AND TIME

A2.1 *General*—All vacuum cleaners, regardless of the width of their nozzles, shall be moved back and forth in a specified pattern on the 54-in. by 18-in. (1370-mm by 460-mm) test area of the carpet for a total of exactly 16 strokes at the rate of 2.5 ± 0.1 s per stroke using any acceptable laboratory method to assure that these specifications are met. Examples of methods that have been found acceptable are visible-marked timing belt or a stopwatch to measure stroke time and cumulative time.

A2.1.1 Measure the outside width of the nozzle housing in inches.

A2.1.2 Divide the nozzle width into 18 and round the result to the nearest larger whole number identified henceforth as N .

A2.1.3 Divide the width of test area (18 in.) into N equal strips and mark the test area accordingly. Note that for any

vacuum cleaners having overall nozzle widths ranging from 3 in. to 17 in. the number of strips will be 6, 5, 4, 3, or 2.

A2.1.4 Place the vacuum cleaner nozzle on the test carpet so that the front edge of the vacuum cleaner coincides with the line defining the beginning of the test area and the right side of the nozzle coincides with the right side boundary shown in the applicable illustration. Ensure that each forward stroke ends with the front edge of the vacuum cleaner coincident with the end of the test area. When the vacuum cleaner reaches the extreme left strip, align the left side of the nozzle with the left side boundary of the test area. See Fig. 6. This shows the pattern for $N = 2$. For variations of the pattern where $N = 2$ to $N = 6$, see Fig. A2.1. Take care to ensure that during each stroke the side of the nozzle, right side or left side as applicable, is kept aligned with the side boundary of the test strip being cleaned, except for crossover strokes.

iTeh Standards
(<https://standards.iteh.ai>)
Document Preview

[ASTM F608-22](#)

<https://standards.iteh.ai/catalog/standards/sist/36847e3d-f0ce-4c67-94b3-06632825189f/astm-f608-22>