



Designation: **F1284 – 09 (Reapproved 2016) F1284 – 22**

## Standard Test Method for Evaluating Carpet Embedded Dirt Removal Effectiveness of Residential Central Vacuum Cleaning Systems<sup>1</sup>

This standard is issued under the fixed designation F1284; the number immediately following the designation indicates the year of original adoption or, in the case of revision, the year of last revision. A number in parentheses indicates the year of last reapproval. A superscript epsilon ( $\epsilon$ ) indicates an editorial change since the last revision or reapproval.

### 1. Scope

1.1 This test method covers only a laboratory test for determining the relative carpet dirt removal effectiveness of residential central vacuum cleaning systems when tested under specified conditions.

1.2 This test method is applicable to residential central vacuum cleaning systems intended for cleaning carpets.

1.3 This test method applies only to embedded dirt removal from carpets, not the removal of surface litter and debris.

1.4 The values stated in inch-pound units are to be regarded as standard. The values given in parentheses are mathematical conversions to SI units that are provided for information only and are not considered standard.

1.5 *This standard does not purport to address all of the safety concerns, if any, associated with its use. It is the responsibility of the user of this standard to establish appropriate safety and health practices and determine the applicability of regulatory limitations prior to use.*

1.6 *This international standard was developed in accordance with internationally recognized principles on standardization established in the Decision on Principles for the Development of International Standards, Guides and Recommendations issued by the World Trade Organization Technical Barriers to Trade (TBT) Committee.*

### 2. Referenced Documents

#### 2.1 ASTM Standards:<sup>2</sup>

D75 Practice for Sampling Aggregates

E11 Specification for Woven Wire Test Sieve Cloth and Test Sieves

E177 Practice for Use of the Terms Precision and Bias in ASTM Test Methods

E691 Practice for Conducting an Interlaboratory Study to Determine the Precision of a Test Method

F608 Test Method for Evaluation of Carpet Embedded Dirt Removal Effectiveness of Household/Commercial Vacuum Cleaners

F655 Specification for Test Carpets and Pads for Vacuum Cleaner Testing (Withdrawn 2022)<sup>3</sup>

F884 Test Method for Motor Life Evaluation of a Built-In (Central Vacuum) Vacuum Cleaner

F922 Test Method for Motor Life Evaluation of an Electric Motorized Nozzle

F1038 Test Method for Motor Life Evaluation of a Canister, Hand-held, Stick, and Utility Type Vacuum Cleaner Without a Driven Agitator

<sup>1</sup> This test method is under the jurisdiction of ASTM Committee F11 on Vacuum Cleaners and is the direct responsibility of Subcommittee F11.21 on Cleanability. Current edition approved April 1, 2016 (Nov. 1, 2022). Published April 2016 (August 2023). Originally approved in 1992. Last previous edition approved in 2009 (2016) as F1284 – 09 (F1284 – 09 (2016)). DOI: 10.1520/F1284-09R16.10.1520/F1284-22.

<sup>2</sup> For referenced ASTM standards, visit the ASTM website, [www.astm.org](http://www.astm.org), or contact ASTM Customer Service at [service@astm.org](mailto:service@astm.org). For *Annual Book of ASTM Standards* volume information, refer to the standard's Document Summary page on the ASTM website.

<sup>3</sup> The last approved version of this historical standard is referenced on [www.astm.org](http://www.astm.org).

**F1334** Test Method for Determining A-Weighted Sound Power Level of Vacuum Cleaners

**F1409** Test Method for Straight Line Movement of Vacuum Cleaners While Cleaning Carpets

### 3. Terminology

#### 3.1 Definitions of Terms Specific to This Standard:

3.1.1 *cleaning ability, n*—the potential of a vacuum cleaner to remove dirt from a surface (sometimes referred to in the industry as *cleanability, dry*).

3.1.2 *model, n*—the designation of a group of vacuum cleaners having identical, mechanical and electrical construction with only cosmetic or nonfunctional differences.

3.1.3 *population, n*—the total of all units of a particular model vacuum cleaner being tested.

3.1.4 *sample, n*—a group of vacuum cleaners taken from a large collection of vacuum cleaners of one particular model, which serves to provide information that may be used as a basis for making a decision concerning the larger collection.

3.1.5 *test run, n*—the definitive procedure that produces a singular measured result.

3.1.6 *test unit, n*—a single vacuum cleaner of the model being tested.

### 4. Significance and Use

4.1 This test method provides a laboratory test for determining the relative carpet dirt removal effectiveness of residential central vacuum cleaning systems when tested under standard conditions and on representative types of carpets.

4.2 This laboratory test method may not give a representation of carpet embedded dirt cleaning effectiveness in the home.

4.3 In order to provide a uniform basis for measuring performance as described in 1.2, standardized test carpets and standardized test dirt are employed in this procedure.

4.4 The results reflect a non-loaded cleaning capability and may not be representative of cleaning capabilities under dirt loading conditions.

### 5. Apparatus

5.1 *Weighing Scale*<sup>4</sup>(for weighing carpets; see 9.1.1.5 and 9.4.5)—The scale must be accurate to 0.035 oz (1 g) and have a weighing capacity of at least 15 lb (6.82 kg).

5.2 *Weighing Scale*<sup>5</sup>(for weighing test dirt and non-disposable dirt receptacles; see 9.2.1.2 and 9.4.12)—The scale must be accurate to 0.0035 oz (0.10 g) and have a weighing capacity of at least 1.1 lb (500 g).

5.3 *Stopwatch* with a second hand, or other type of equipment capable of establishing the specified rate of movement and total cycle time.

5.4 *Voltmeter*, to measure input volts to the cleaning system to provide measurements accurate to within  $\pm 1\%$ .

5.5 *Voltage Regulator System*, to control the input voltage to the vacuum cleaner. The regulator shall be capable of maintaining the vacuum cleaner's rated voltage  $\pm 1\%$  and rated frequency having a wave form that is essentially sinusoidal with 3 % max harmonic distortion for the duration of the test.

<sup>4</sup> The OHAUS Models GT-8000, LB30-CO and 1119D, all available from OHAUS, Inc. Florham Park, NJ, or the equivalent, have been found suitable for this purpose. It is recommended that the scale read directly in grams.

<sup>5</sup> The Mettler-Toledo Model PM 2000, available from Mettler-Toledo, Inc., Box 71, Highstown, NJ, 08520. The OHAUS Model-GT-8000 available from OHAUS, Inc., Florham Park, NJ, or equivalent, have been found suitable for this purpose. It is recommended that the seal read directly in grams.

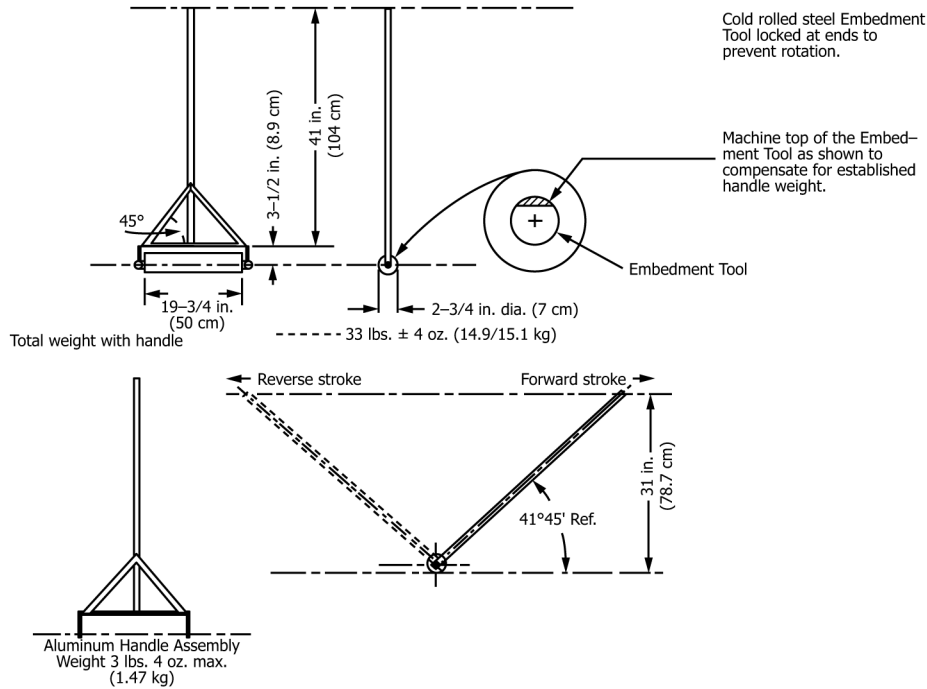

FIG. 1 Dirt Embedment Tool

5.6 *Dirt Embedment Tool*, with the roller locked (see Fig. 1).

5.7 *Dirt Dispenser*—Dispensing system that provides the operator with a method to distribute the test dirt uniformly on the carpet test area.

5.8 *Carpet Conditioning Equipment*, to support the test carpet during new carpet conditioning and the removal of residual dirt from the test carpet before each test run (Fig. 2).

5.9 *Rotating Agitator Conditioning Vacuum Cleaner/Equipment*, for conditioning new test carpets and removing residual dirt from the test carpet before each test run. This cannot be the unit being tested.

NOTE 1—Automated methods for spreading the test dirt, embedding the test dirt, and cleaning and reconditioning the test carpets are acceptable if they do not change the results of this test method.

5.10 *Temperature and Humidity Indicators*, to provide temperature measurements accurate to within  $\pm 1^{\circ}\text{F} \pm 1^{\circ}\text{F}$  ( $\pm 1/2^{\circ}\text{C}$ ) and humidity measurements accurate to within  $\pm 2\%$  relative humidity.

5.11 *Supporting Surface*—A flat surface consisting of a piece of 3/4-in. (19-mm) thick exterior-grade plywood with the “A” surface upward to support the test carpet and pad. If necessary, the four corners (only) of the test carpet and pad may be fastened to the supporting surface by any acceptable means.

5.12 *Rotating Agitator Reference Vacuum Cleaner*, one, for calibrating test carpets (see 9.2.4).

5.13 *Straight-Air Canister Reference Vacuum Cleaner*, one, for calibrating test carpets (see 9.2.4).

5.14 *Orifice Adapter Tube*—See Fig. 3.

## 6. Materials

6.1 *Standard Carpets*, conforming to Specification F655.

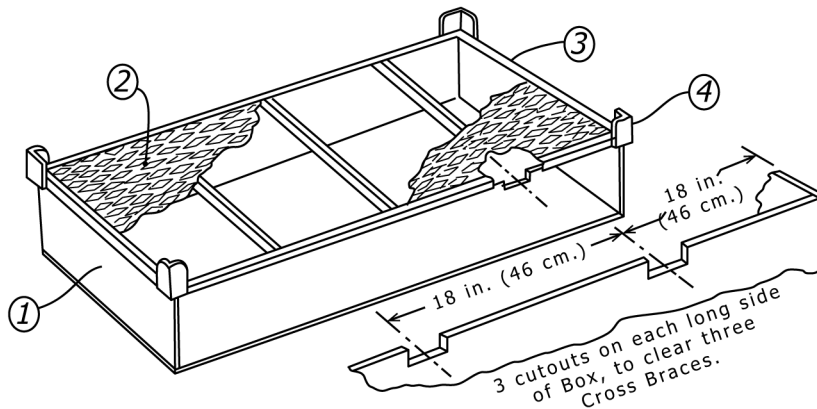

- ① -- Five Sided Box with open top.  
 Outside Dimensions, Length -- 72 in. (183 cm.)  
 Width -- 27 in. (69 cm.)  
 Depth -- 12 in. (30.5 cm.)  
 Material -- Plywood, 3/4 in. (1.9 cm.) thick.  
 Optional -- Bottom of box may be sloped downward to center opening to simplify emptying of test dirt accumulation.
- ② -- Flattened Expanded Steel Top Panel, .070 in. (1.8 mm) thick, with "75% open" area, and with diamond shaped openings:--  
 center-to-center, 2.1 in. (5.3 cm.) LWD  
 center-to-center, 0.93 in. (2.4 cm.) SWD  
 opening dimensions, 1.78 in. (4.5 cm.) LWD  
 opening dimensions, 0.688 in. (1.7 cm.) SWD  
 NOTE: Demcor Style "3/4 in.-#13" material has been found to be acceptable. (Designer's Metal Div'n. of Southern Electric, Inc.)

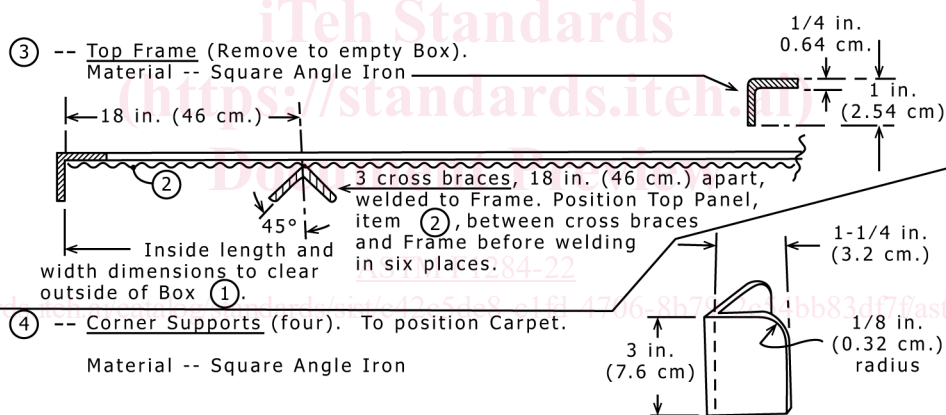

- ③ -- Top Frame (Remove to empty Box).  
 Material -- Square Angle Iron
- ④ -- Corner Supports (four). To position Carpet.  
 Material -- Square Angle Iron

FIG. 2 Carpet Cleaning Rack

6.2 Standard Carpet Padding, conforming to Specification F655.

6.3 Test Dirt (see Annex A1).

6.3.1 Silica Sand—(see Annex A1).

6.3.2 Talc—see (Annex A1).

## 7. Sampling

7.1 A minimum of three units of the same model vacuum cleaner selected at random in accordance with good statistical practice shall constitute the population sample.

7.1.1 To determine the best estimate of the cleaning ability effectiveness for the population of the vacuum cleaner model being tested, the arithmetic mean of the cleaning ability rating of the sample from the population shall be established by testing it to a 90 % confidence level within  $\pm 5\%$  of the mean value of the cleaning ability rating.

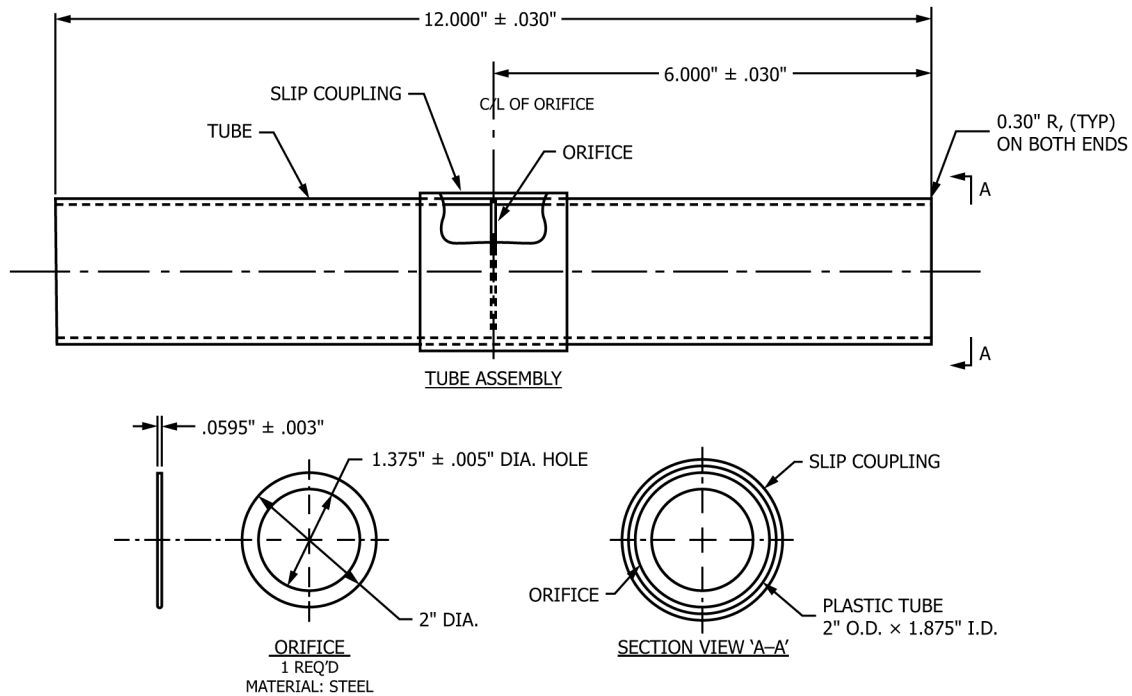

**TUBE AND ORIFICE ASSEMBLY**

**FIG. 3 Orifice Adapter Tube**

(<https://standards.iteh.ai>)  
 Document Preview

7.1.2 Annex A3 provides a procedural example for determining the 90 % confidence level and when the sample size shall be increased.

ASTM F1284-22

NOTE 2—See Annex A3 for method of determining 90 % confidence level.

**8. Conditioning**

8.1 Test Room—Maintain the test room in which all conditioning and vacuum cleaner testing is done at  $70 \pm 5^{\circ}\text{F}$  ( $21 \pm 3^{\circ}\text{C}$ ) and  $4570^{\circ}\text{F} \pm 5^{\circ}\text{F}$  ( $21^{\circ}\text{C} \pm 3^{\circ}\text{C}$ ) and 45 % to 55 % relative humidity.

8.2 All components involved in the test must remain and be exposed in the controlled environment for at least 16 h prior to the start of the test.

**9. Procedure**

9.1 Test Carpet Preparation (see Fig. 4):

9.1.1 Preconditioning New Test Carpet Samples:

9.1.1.1 New Test Carpets shall conform to Specification F655.

9.1.1.2 Cut a sample of each test carpet to a size of  $2727$  in. by 72 in. ( $690$ ( $690$  mm by 1830 mm) minimum. If the warp direction or “lay” of the carpet can be determined, it shall be in the 72 in. direction as indicated in Fig. 5. Carpets shall be bound on all sides.

9.1.1.3 Mark the test area on each carpet as indicated in Fig. 5.

9.1.1.4 Precondition New Test Carpet Samples:

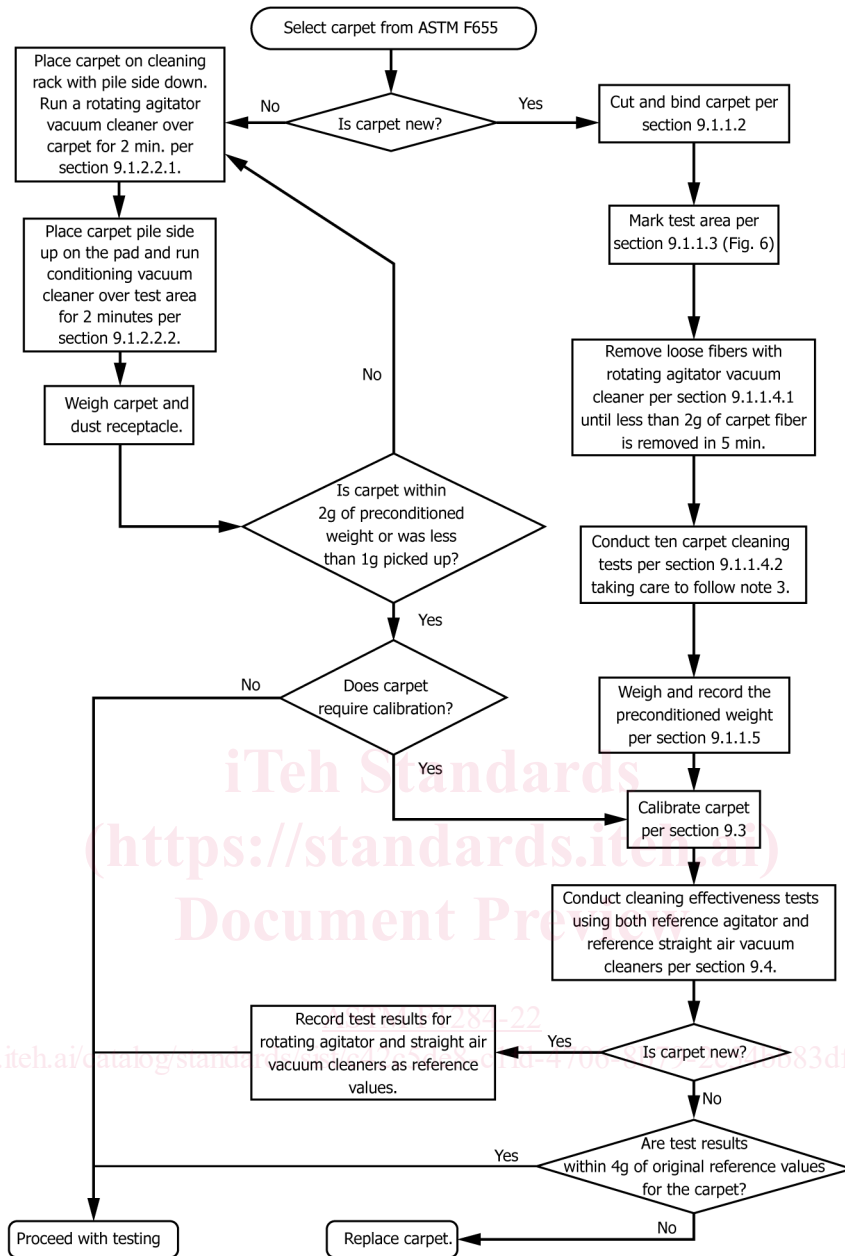
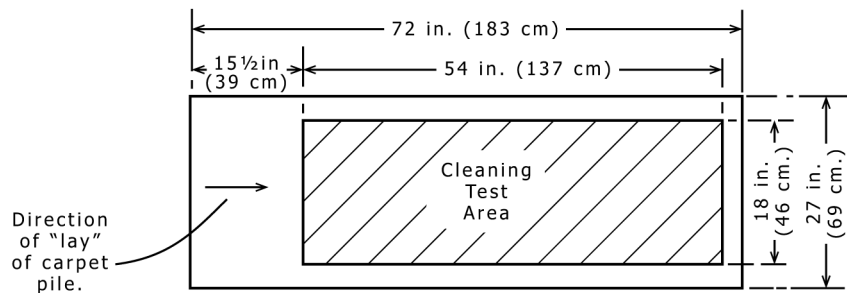

FIG. 4 Carpet Conditioning/Calibration Procedure



NOTE 1—Cleaning test area should be positioned as shown. First forward stroke of rotating agitator or carpet is in direction *with* lay of carpet.

FIG. 5 Test Carpet

(1) Precondition the entire area of the carpet by cleaning with the rotating agitator conditioning vacuum cleaner. Continue the operation until less than 0.07 oz (2 g) of carpet fiber is picked up in 5 min.

(2) Run ten carpet-embedded dirt removal effectiveness test runs in accordance with Sections 9.4.6 – 9.4.19.

NOTE 3—Recondition the new test carpet following each preconditioning test run. It is not necessary, however, to meet the requirements set forth in 9.1.2.1 with respect to the preconditioned weight.

9.1.1.5 Weigh and record the preconditioned weight of the carpet.

9.1.1.6 Run a test carpet calibration in accordance with Section 9.3.

#### 9.1.2 *Reconditioning Used Test Carpet Samples:*

9.1.2.1 **Initial Daily Reconditioned Weight:** At the beginning of each day, it is necessary to remove any dirt that may have settled on the carpet surface and stabilize the moisture content of the carpet. Clean the carpet with a rotating agitator conditioning vacuum cleaner until its weight does not exceed the initial reconditioned weight from the previous day of testing by more than 0.07 oz (2 g) or less than 0.035 oz (1 g) is picked up by the conditioning vacuum cleaner using the procedure in 9.1.2.3.

9.1.2.2 Following each test run, it is necessary to remove the residual dirt and stabilize the moisture content of the carpet. Clean the carpet with a rotating agitator conditioning vacuum cleaner until its weight does not exceed the initial daily reconditioned weight requirement of 9.1.2.1 by more than 0.07 oz (2 g) or less than 0.035 oz (1 g) is picked up by the conditioning vacuum cleaner using the following procedure.

##### 9.1.2.3 *Procedure:*

(1) Place the carpet on the carpet cleaning rack (Fig. 2) with the pile side down. Run the rotating agitator conditioning vacuum cleaner over the carpet for 2 min concentrating on the test area at 1.8 ft/s (0.55 m/s); then run the rotating agitator conditioning vacuum cleaner thoroughly over the entire carpet area at least one time.

(2) Place the carpet (pile side up) on the pad, on the plywood supporting surface, and clean it with the rotating agitator conditioning vacuum cleaner for 2 min, concentrating on the test area; then run the rotating agitator vacuum cleaner thoroughly over the entire area at least one time.

(3) Weigh the carpet.

(4) Keep alternating 9.1.2.3(1) and 9.1.2.3(2), always ending with the pile side up, until the carpet weight meets the requirement of 9.1.2.1 or 9.1.2.2.

(5) Change the disposable primary filter after a maximum of every 4 runs on the conditioning vacuum cleaner or more often if required.

(6) Reconditioning equipment that uses nondisposable filters should have the filter or filters cleaned after every four carpet reconditioning runs or more often, if required.

NOTE 4—A high-cleaning performance rotating agitator vacuum cleaner is recommended for reducing the time to recondition the carpet.

#### 9.1.3 *Reconditioning Used Carpet Padding:*

9.1.3.1 Clean the carpet padding by shaking weekly or more often, if necessary, to remove any collected dirt.

9.1.3.2 Replace the carpet padding when it has holes, tears, or other signs of wear.

#### 9.2 *Preparation of Test Systems and Cleaning Tools (see Fig. 6):*

##### 9.2.1 *New Test Systems and Cleaning Tools:*

9.2.1.1 Run the system in at rated voltage  $\pm 1$  % and rated frequency with filters in place.

(1) If a rotating agitator type cleaning tool is included with the system operate it for 1 h with agitator bristles not engaged on any surface.

9.2.1.2 For vacuum cleaners with non-disposable dirt receptacles, weigh and record the receptacle's original weight to the nearest 0.0035 oz (0.10 g). This may not be possible with some systems in which the nondisposable filter cannot be removed.

##### 9.2.2 *Used Test Vacuum Cleaners:*

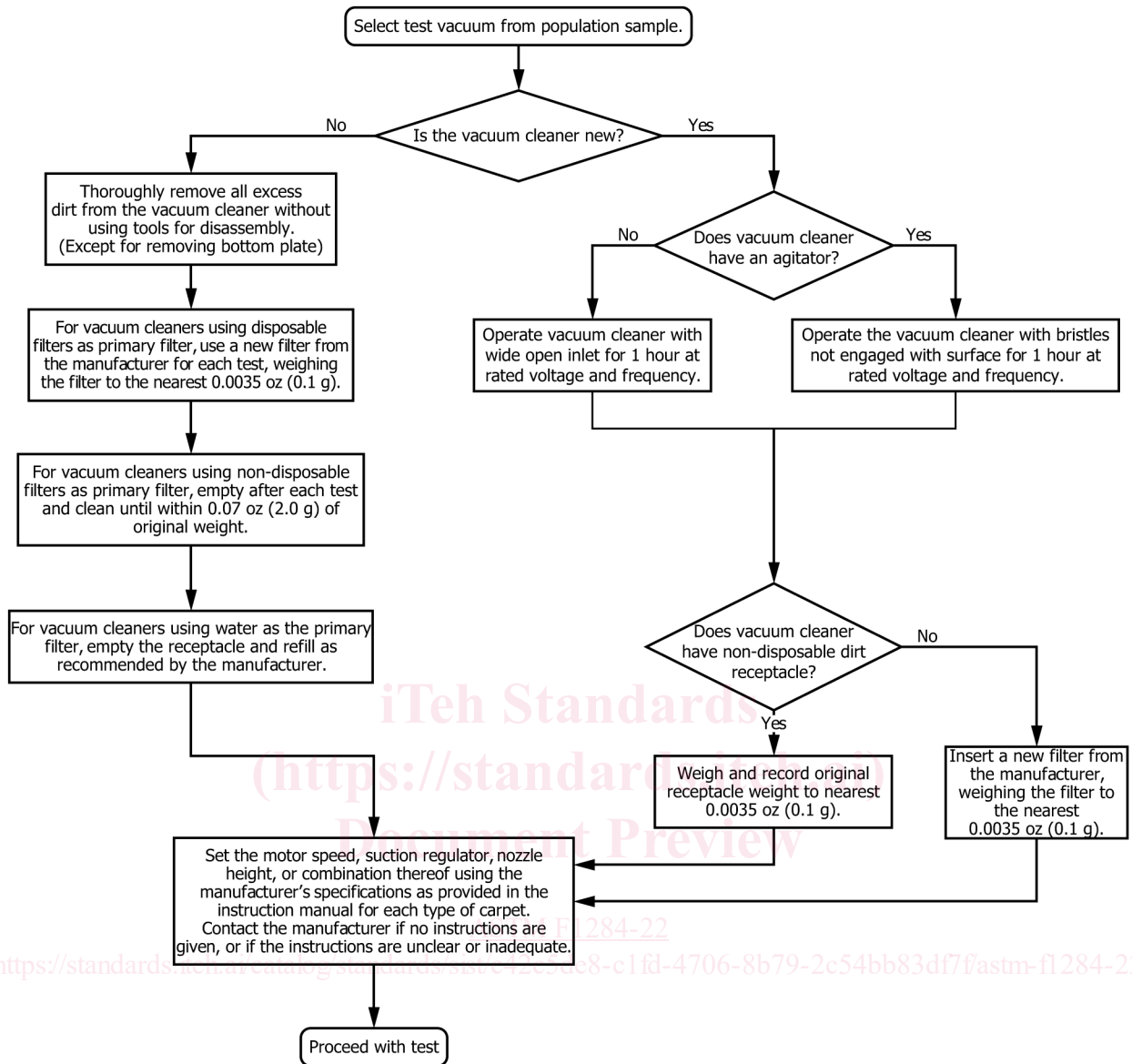

FIG. 6 Vacuum Cleaner Conditioning Procedure

9.2.2.1 Recondition a used test vacuum cleaner, prior to each test run, as follows:

(1) Thoroughly remove excess dirt from the test system. Without using tools for disassembly, clean the entire outer surface, brushes, nozzle chamber, ductwork, inside of the chamber surrounding the primary filter, and inside hose and wands. Check the condition of all mechanisms for signs of wear or damage. (See Note 5.)

(2) For systems using disposable filters as the primary filters, use a new disposable primary filter from the manufacturer for each test run. Weigh the filter to the nearest 0.0035 oz (0.10 g) and install it as recommended by the vacuum cleaner manufacturer. Thoroughly clean the inside of the chamber surrounding the primary filter each time the filter is replaced.

(3) For systems using cloth filter bags or other types of nondisposable dirt receptacles, empty according to manufacturer's instructions after each test run, and clean the cloth filter bag or nondisposable dirt receptacle until its weight is within 0.07 oz (2 g) of its original weight. Thoroughly clean the inside of the chamber surrounding the primary filter. Weigh the receptacle to the nearest 0.0035 oz (0.10 g) and install it as recommended by the vacuum cleaner manufacturer.

NOTE 5—It is recommended that a replaceable brush drive belt for cleaning tool agitators be changed after each four test runs, if considered applicable, using manufacturer's instructions. Any other maintenance task, such as cleaning the brush belt with distilled water, should only be done in accordance with manufacturer's recommendations.

9.2.3 Test System and Tool Settings:



9.2.3.1 If various settings are provided, set the motor speed setting, suction regulator, nozzle height, or combination thereof using the manufacturer's specifications as provided in the instruction manual for each type of carpet. Contact the manufacturer if no instructions are given, or if the instructions are unclear or inadequate.

9.2.3.2 All straight line movement (see Test Method F1409), sound power (see Test Method F1334), and motor life evaluation (see Specification F655 and Test Methods F884, F922, and F1038) tests shall be conducted using the same settings (nozzle, motor speed, suction regulator, etc.) for each specific carpet.

#### 9.2.4 *Reference Vacuum Cleaners or Systems (Calibration):*

9.2.4.1 Use the reference vacuum cleaners or systems only for determining the reference rating of carpets and for the verification of carpet acceptability (see 9.3).

9.2.4.2 Maintain the performance of the reference vacuum cleaners or systems throughout the acceptable life of the carpet (that is, nozzle suction, bristle extension, motor and agitator speeds, etc...).

#### 9.3 *Test Carpet Calibration:*

9.3.1 The purpose of calibration is to determine when the test carpet needs to be replaced by establishing a reference rating for each new preconditioned test carpet and to check this rating 50 or fewer test runs.

9.3.2 The reference ratings are determined for each test carpet by the percent pickup using the reference rotating agitator vacuum cleaner or system and the reference straight-air vacuum cleaner or system.

9.3.3 The percent pickup is determined by performing a carpet-embedded dirt removal effectiveness test (see 9.4).

9.3.4 When the embedded dirt rating for either reference cleaner varies by 0.14 oz (4 g) from the original reference rating for the carpet, replace the carpet.

NOTE 6—Carpet pick up changes over time as the test carpet panel is used due to normal carpet wear. General laboratory practice is to track and record the number of test runs on each carpet panel. It is recommended to estimate, as closely as possible, the number of required test runs on all carpet panels intended to be used prior to starting any test program in order to establish that the selected carpet panels have a sufficient number of test runs left to complete the test program. All products being tested in a comparison test must be tested on the same calibrated carpet panel throughout the test program. If a particular carpet panel is found to no longer be acceptable for testing due to the 0.14 oz (4 g) limit being exceeded during a calibration check, all products tested on that particular carpet panel during the test program must be retested on the new carpet panel to ensure proper comparison.

#### 9.4 *Carpet Embedded Dirt Removal Effectiveness Test:*

9.4.1 Set up the system as shown in Fig. 7. On the intake side, use an orifice tube adapter terminating with a wall inlet valve. Insert into the wall valve a flexible cleaning hose as provided with the system. The hose, wands, and nozzle should be those normally offered with the particular unit being tested. If more than one hose, wand, or nozzle type is offered with the unit, the manufacturer's part, catalog or model number of the ductwork, fittings, hose, wands, and nozzle used in the test must be recorded and presented as part of the cleaning effectiveness rating.

9.4.2 For those systems which include exhaust tubing and muffler, their use will be mandatory for testing.

NOTE 7—If necessary, the power unit may be positioned outside the test laboratory environment.

9.4.3 Prepare test carpets in accordance with 9.1.1 for new carpets or 9.1.2 for used carpets.

9.4.4 If preconditioning or reconditioning has been done more than 1 h before a test run, weigh the carpet. If the weight of the carpet exceeds the preconditioned or reconditioned weight by more than 0.07 oz (2 g), clean the carpet with a rotating agitator conditioning vacuum cleaner until these criteria are met.

9.4.5 Carefully weigh the test carpet immediately before placing it on the test platform. Record the weight to the nearest 0.035 oz (1.0 g).

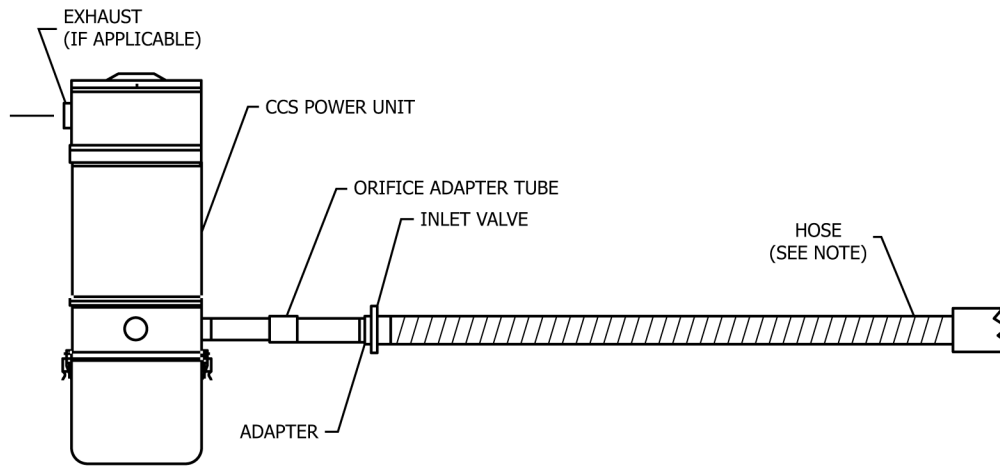

NOTE 1—Due to the height required for the tubing assembly, the assembly (in a plane) can be at any angle from vertical to parallel with the floor.  
 NOTE 2— If flexible tubing is used for pipe sections, then flexible tubing must be supported in a straight line.  
 NOTE 3—Hose is to be laid out in a straight line so as to minimize kinks or bends.

**FIG. 7 Vacuum Cleaning System Test Set-Up**

9.4.6 Position the test carpet on the padding (with “scrim” side of the padding up) on the supporting surface (see 5.11).

9.4.7 The test cleaners and dirt receptacles should be prepared in accordance with Section 9.2.

9.4.8 Weigh the prepared dirt receptacle (that is, dust bag or other primary filter device) prior to conducting the measurement test run. Record the weight to the nearest 0.0035 oz (0.10 g).

9.4.9 Install the primary filter as explained below.

9.4.9.1 For vacuum cleaners using disposable or non-disposable primary filters, install the primary filter from the manufacturer per their instructions.

9.4.10 Ensure that the vacuum cleaner settings have been made in accordance with 9.2.3.

9.4.11 *Test Dirt Preparation*—Weigh and mix  $3.173.17 \text{ oz} \pm 0.0035 \text{ oz}$  ( $90(90 \text{ g} \pm 0.1 \text{ g})$ ) of silica sand and  $0.350.35 \text{ oz} \pm 0.0035 \text{ oz}$  ( $10(10 \text{ g} \pm 0.1 \text{ g})$ ) of commercial grade talcum, both conforming to the specifications found in Annex A1.

9.4.11.1 Silica Sand shall be sieved to assure conformance to the specification of A1.2. Sieving shall be performed in accordance with Test Method D75.

9.4.11.2 Bulk mixing and storage of sieved constituents of silica sand is acceptable if assay analysis meets the specification of A1.2.

9.4.11.3 Bulk storage of test dirt mixture (sand plus talc) is not allowed.

9.4.12 Distribute 3.52 oz (100 g) of the test dirt uniformly on the cleaning test area (see Fig. 5), using any convenient spreading method.

9.4.13 Embed the test dirt into the carpet using the dirt embedment tool shown in Fig. 1. Perform the embedding process by using a dragging motion in both directions with the handle held at the angle shown. Drag the dirt embedment tool over the test area exactly 30 strokes, alternating directions forward and back. (A movement in one direction is one “stroke.”) Use a uniform movement to provide a “stroke” time of 2.5 s (a rate of 1.8 ft/s (0.55 m/s)). The first forward stroke shall be in the direction of the carpet lay.

NOTE 8—An acceptable laboratory practice shall be used to ensure that the embedment tool shall not fall short of reaching the end boundaries of the test area, and the tool shall cover both side boundaries of the test area at all times.

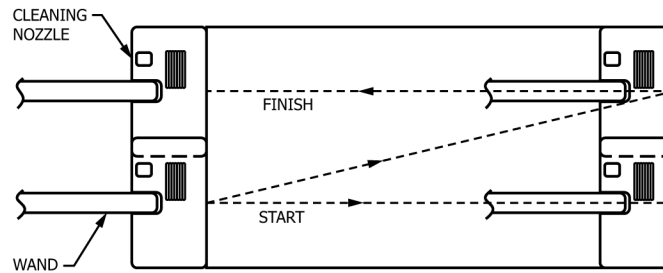

NOTE 1—Shown are the nozzle positions for the cleaning pattern when  $N = 2$  (refer to Annex A2).

FIG. 8 Cleaning Nozzle Position at Start and Finish of Test Cleaning Strokes

9.4.14 Clean the embedding tool as needed.

9.4.15 If the system or cleaning tool has not been energized for more than 60 min, energize the system or cleaning tool for 2 min at nameplate rated voltage ( $\pm 1\%$ ) and frequency ( $\pm 1$  Hz) immediately preceding the test sequence of 9.4.12. For systems and cleaning tools with dual nameplate voltage ratings, conduct testing at the highest voltage.

9.4.15.1 For a rotating agitator-type cleaning tools, place it such that the bristles clear the supporting surface and no loose dirt is picked up.

9.4.15.2 For a straight-air system or cleaning tool, operate with the rug tool unrestricted, positioned such that no loose dirt is picked up from the supporting surface.

9.4.16 Immediately following the 2-min “run-in” of 9.4.11, de-energize the vacuum cleaner and place the vacuum cleaner nozzle on the test carpet so that the front edge of the vacuum cleaner coincides with the line defining the beginning of the test area and the right side of the boundary of the 18-in. test width (see Fig. 8). The forward stroke of the nozzle shall be in the direction of the carpet lay (see Fig. 5).

9.4.16.1 Reasonable efforts shall be made to maintain the handle height at 31.5 in. (0.8 m) during each test run for cleaning tools with a pivoting handle.

9.4.16.2 Reasonable efforts shall be made to maintain the cleaning tool’s nozzle parallel to the test carpet surface during each test run for vacuum cleaners with non-pivoting handles.

9.4.17 Tilt or lift the nozzle off the carpet, energize the system, and adjust the voltage to rated voltage  $\pm 1\%$ . Allow the system to run and expand the filter bag, if one is present.

9.4.18 *Test Cleaning Pattern:*

9.4.18.1 For a rotating agitator-type cleaning tool, lower the nozzle onto the carpet before the test area. Again, adjust the voltage to rated voltage  $\pm 1\%$ ; then move the nozzle at a rate of 1.8 ft/s (0.55 m/s) in the test cleaning pattern and motion as specified in Annex A2 during the cleaning cycle. Maintain the nozzle position and settings as specified in 9.2.3 during the cleaning cycle.

9.4.18.2 For a straight-air cleaning tool, position the nozzle on the carpet before the test area. Again, adjust the voltage to rated voltage  $\pm 1\%$ ; then move the nozzle at a rate of 1.8 ft/s (0.55 m/s) in the test cleaning patterns and motion as described in Annex A2. Maintain the nozzle position and settings as specified in 9.2.3 during the cleaning cycle.

9.4.18.3 At the end of the last stroke, smoothly tilt or lift the cleaning tool nozzle off the carpet and allow the system to run an additional 10 s to clear the system of test dirt actually picked up but temporarily trapped within it before de-energizing the system. During the additional run period, the hose used with the system should be flexed to help clear the system.

9.4.19 Determine the grams of dirt picked up by subtracting the weight of the dirty carpet after test from the weight of the preconditioned or reconditioned carpet at the start of the test plus 3.53 oz (100 g). Record the results to the nearest 0.035 oz (1.0 g).

9.4.20 Using the same test central vacuum cleaning system, repeat 9.4.1 – 9.4.18 two additional times for a total of three test runs.