



Designation: D2266 – 23

Standard Test Method for Wear Preventive Characteristics of Lubricating Grease (Four-Ball Method)¹

This standard is issued under the fixed designation D2266; the number immediately following the designation indicates the year of original adoption or, in the case of revision, the year of last revision. A number in parentheses indicates the year of last reappraisal. A superscript epsilon (ϵ) indicates an editorial change since the last revision or reappraisal.

This standard has been approved for use by agencies of the U.S. Department of Defense.

1. Scope*

1.1 This test method covers the determination of the wear preventive characteristics of greases in sliding steel-on-steel applications. It is not intended to predict wear characteristics with metal combinations other than steel-on-steel or to evaluate the extreme pressure characteristics of the grease.

1.2 The values stated in SI units are to be regarded as the standard except where the test apparatus or consumable parts are only available in other units. In such cases, these will be regarded as standard. The values given in parentheses are for information only.

1.3 *This standard does not purport to address all of the safety problems, if any, associated with its use. It is the responsibility of the user of this standard to establish appropriate safety, health, and environmental practices and determine the applicability of regulatory limitations prior to use.*

1.4 *This international standard was developed in accordance with internationally recognized principles on standardization established in the Decision on Principles for the Development of International Standards, Guides and Recommendations issued by the World Trade Organization Technical Barriers to Trade (TBT) Committee.*

2. Referenced Documents

2.1 ASTM Standards:²

[D4172 Test Method for Wear Preventive Characteristics of Lubricating Fluid \(Four-Ball Method\)](#)

[D4175 Terminology Relating to Petroleum Products, Liquid Fuels, and Lubricants](#)

[D6300 Practice for Determination of Precision and Bias Data for Use in Test Methods for Petroleum Products, Liquid Fuels, and Lubricants](#)

2.2 *ANSI Standard:*³

[B3.12 for Metal Balls](#)

3. Terminology

3.1 Definitions:

3.1.1 For definitions of terms used in this test method, refer to Terminology [D4175](#).

3.2 There are no terms in this test method that require new or other than dictionary definitions.

4. Summary of Test Method

4.1 Three ½ in. (12.7 mm) diameter steel balls are clamped together and covered with the lubricant to be evaluated. A fourth ½ in. diameter steel ball, referred to as the top ball, is pressed with a force of 40 kgf (392 N) into the cavity formed by the three clamped balls for three-point contact. The temperature of the lubricating grease specimen is regulated at 75 °C (167 °F) and then the top ball is rotated at 1200 r/min for 60 min. Lubricants are compared by using the average size of the scar diameters worn on the three lower clamped balls.

NOTE 1—Because of differences in the construction of the various machines on which the four-ball test can be made, the manufacturer's instructions should be consulted for proper machine setup and operation.

NOTE 2—Although the test can be run under other test parameters, the precision noted in Section 11 can vary when testing with other than test parameters listed in Section 8.

5. Significance and Use

5.1 The four-ball wear-test method can be used to determine the relative wear-preventing properties of greases under the test conditions and if the test conditions are changed the relative ratings may be different. No correlation has been established between the four-ball wear test and field service. The test

¹ This test method is under the jurisdiction of ASTM Committee D02 on Petroleum Products, Liquid Fuels, and Lubricants and is the direct responsibility of Subcommittee D02.G0.04 on Functional Tests - Tribology.

Current edition approved July 1, 2023. Published August 2023. Originally approved in 1964. Last previous edition approved in 2015 as D2266 – 01 (2015). DOI: 10.1520/D2266-23.

This test method has been adopted for use by government agencies to replace Method 6514 of Federal Test Method Standard No. 791b.

² For referenced ASTM standards, visit the ASTM website, www.astm.org, or contact ASTM Customer Service at service@astm.org. For *Annual Book of ASTM Standards* volume information, refer to the standard's Document Summary page on the ASTM website.

³ Available from American National Standards Institute (ANSI), 25 W. 43rd St., 4th Floor, New York, NY 10036, <http://www.ansi.org>.

*A Summary of Changes section appears at the end of this standard

method cannot be used to differentiate between Extreme Pressure (EP) and Non-Extreme Pressure (Non-EP) Greases.⁴

6. Apparatus

6.1 *Four-Ball Wear-Tester and Accessories*—See Fig. 1 and Fig. 2.⁵

NOTE 3—It is important to distinguish between the Four-Ball EP Tester and the Four-Ball Wear Tester. The Four-Ball EP Tester is designed for testing under heavier loads and more severe conditions; it lacks the sensitivity necessary for performing four-ball wear test.

6.2 *Microscope*,⁶ capable of measuring the diameters of the scars produced on the three stationary balls to an accuracy of 0.01 mm. It is more efficient to measure the scars without removing the three balls from the holder.

7. Reagents and Materials

7.1 *Test Balls*⁷, chrome alloy steel, made from AISI standard steel No. E-52100, with diameter of 0.5 in. (12.7 mm), Grade

⁴ Further details on this test method may be found in the article by Stalling, L., *NLGI Spokesman*, Vol 31, No. 11, February 1988, pp. 396–401. This article has been submitted as a research report, but it does not follow research report guidelines because the work was conducted before research report guidelines were instituted.

⁵ The sole source of supply of the Four-Ball Wear Test Machine known to the committee at this time is Falex Corp., 1020 Airpark Drive, Sugar Grove, IL 60554. If you are aware of alternative suppliers, please provide this information to ASTM International Headquarters. Your comments will receive careful consideration at a meeting of the responsible technical committee,¹ which you may attend.

This company can also furnish a microscope with a special base to measure the wear scars without removing the balls from the test-oil cup. Discontinued models of the Four-Ball Wear Test Machine made by Precision Scientific Co. and Roxanna Machine Works are also satisfactory.

⁶ The sole source of supply of the microscope known to the committee at this time is Falex Corp., 1020 Airpark Drive, Sugar Grove, IL 60554. If you are aware of alternative suppliers, please provide this information to ASTM International Headquarters. Your comments will receive careful consideration at a meeting of the responsible technical committee,¹ which you may attend.

Falex Corp. Microscope F-1519-31 measures directly to 0.1 mm and by interpolation to 0.01 mm. A higher resolution version, F-1519-31A, measures to 0.001 mm.

⁷ Steel balls meeting this description were used in developing the precision of the test. They are available from the manufacturer of the test machine and some ball manufacturers. Some operators prefer to check a new box of balls by running an oil or a lubricating grease with a known reference. All balls used in one test should be taken from one carton (of 500 balls) as received from the supplier.

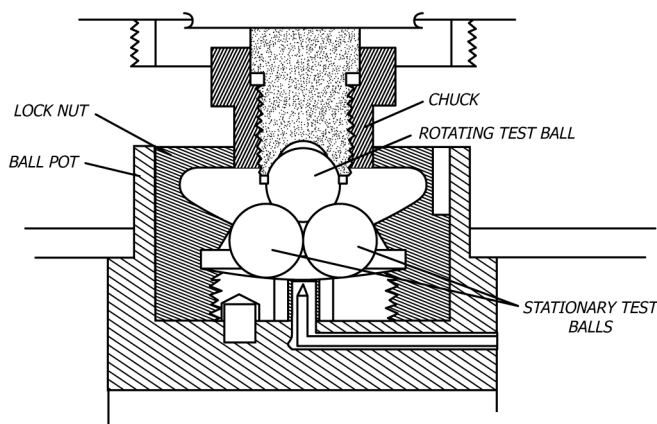

FIG. 2 Falex Corporation (Roxanna) Four-Ball Test Arrangement

25 EP (Extra Polish). Such balls are described in B3.12, for Metal Balls. The Extra-Polish finish is not described in that specification. The Rockwell C hardness shall be 64 to 66, a closer limit than is found in the ANSI requirement.

NOTE 4—Steel balls meeting this description were used in developing the precision of the test.

7.2 *Cleaning Fluids* for preparing balls and apparatus for the test should be those capable of removing metal preservative coating from the balls, eliminating carryover effects from one test to the next. The cleaning fluid selected should be non-film-forming and not contribute to the wear or antiwear properties of the test lubricant. (for example, chlorinated solvents should not be used.)

8. Test Conditions

8.1 The test shall be conducted under the following conditions:

Temperature	75 °C ± 2 °C (167 °F ± 4 °F)
Speed	1200 r/min ± 60 r/min
Duration	60 min ± 1 min
Load	40 kgf ± 0.2 kgf (392 N ± 2 N)

NOTE 5—Although the test can be run under other conditions, the precision limits described in Section 11 apply only to tests conducted under the conditions described in Section 8.

9. Preparation of Apparatus

9.1 Set up the drive of the test machine to obtain a spindle speed of 1200 r/min ± 60 r/min.

9.2 Set the temperature controller to maintain a test temperature of 75 °C ± 2 °C (167 °F ± 4 °F).

9.3 When an automatic timer is used to terminate a test, it should be checked for the required ±1 min accuracy at 60 min elapsed time.

9.4 The loading mechanism must be balanced to a zero reading with all parts and test grease in place. To demonstrate proper precision, an addition or subtraction of 0.2 kgf (19.6 N) should be detectable in imbalance. Determination of accuracy of loading at 40 kgf (392 N) is difficult and generally is limited to careful measurement of lever-arm ratios and weights with

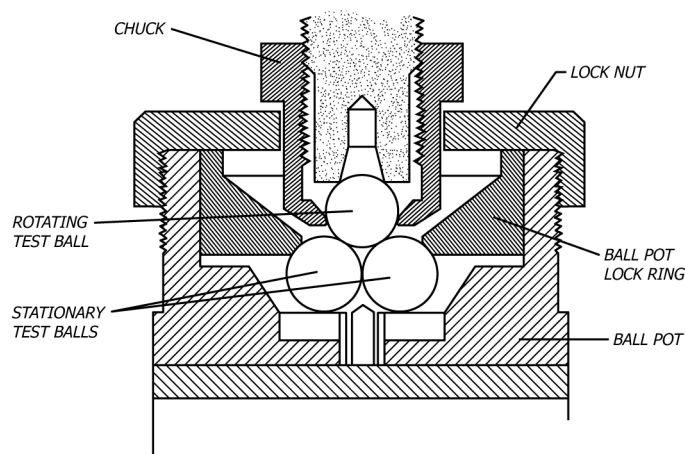

FIG. 1 Precision Scientific Company Four-Ball Test Arrangement

dead-weight loading apparatus or piston diameter and calibration of pressure gauge with pneumatic loading systems.

10. Procedure

10.1 Thoroughly clean four test balls, clamping parts for the upper and lower balls and the oil cup using a cleaning fluid or fluids selected in 7.2. Ultrasonic vibration can be used to assist the cleaning process. Wipe the parts using a fresh (unused) lint-free industrial wipe. After cleaning, handle all parts using a fresh wipe. No trace of cleaning fluid should remain when the test oil is introduced and the machine assembled.

10.2 Insert one of the clean test balls into the ball chuck. Insert the ball chuck into spindle of the test machine and tighten according to the equipment manufacturer's directions.

NOTE 6—Insertion of the ball into the ball chuck should require moderate force and result in an audible snap as the test ball enters the ball chuck. The ball should be free from any movement. If the ball rotates or moves within the ball chuck, replace the ball chuck.

10.3 Place a small amount of the grease in the ball cup sufficient to fill the void space between the three balls to be inserted and the bottom of the ball cup. Insert the three test balls in the ball cup and lock the balls in position by hand tightening the locknut into the ball cup using the wrench supplied by the equipment manufacturer.

NOTE 7—Hand tightening has been found to be between 33.8 N·m and 67.8 N·m (25 lb·ft to 50 lb·ft).

10.4 Coat the test balls located in the ball chuck and ball cup completely and thoroughly with the test grease and then fill the ball cup with grease and level off with the top surface of the locknut.

10.5 Place the ball cup assembly containing the three test balls and grease specimen on the test machine. Avoid shock loading by slowly applying the test load.

10.6 After reaching the desired test load, turn on the temperature controller and set the controller to maintain $75\text{ }^{\circ}\text{C} \pm 2\text{ }^{\circ}\text{C}$ ($167\text{ }^{\circ}\text{F} \pm 4\text{ }^{\circ}\text{F}$).

NOTE 8—Heater voltage or offset on proportional controllers should be capable of bringing stabilized temperature within the prescribed limits.

10.7 When the desired test temperature is reached, simultaneously start the timer and the drive motor, previously set to $1200\text{ r/min} \pm 60\text{ r/min}$.

10.8 After the drive motor has been on for $60\text{ min} \pm 1\text{ min}$, turn off the heaters and drive motor and remove the ball cup and three-ball assembly. (**Warning**—Parts may be hot at the end of the test. Exercise care when handling parts.)

10.9 Measure the wear scars on the three lower balls to an accuracy of $\pm 0.01\text{ mm}$ by one of the following methods:

10.9.1 *Option A*—Clean the grease from the ball cup assembly without loosening the test balls and wipe the scar area with

a tissue. Leave the three balls clamped and set the ball cup assembly on the special base of the microscope that has been designed for this purpose.⁶ Make two measurements on each of the wear scars. Take one measurement of the scar along a radial line from the center of the holder; take the second measurement along a line that is 90° from the first measurement. Report the arithmetic average of the six measurements as the scar diameter in millimetres.

10.9.2 *Option B*—Remove the three lower balls from their clamped position. Wipe the scar area. Take two measurements at 90° to each other. If a scar is elliptical, take one measurement with the striations and the other across the striations. Take care to ensure that the line of sight is perpendicular to the surface being measured. As in Option A, average the six scar readings and report as scar diameter in millimetres.

NOTE 9—In Test Method D4172, it is stated that if the average of the two measurements on one ball varies from the average of all six readings by more than 0.04 mm, the user should investigate the alignment of the three lower balls with the top ball.

11. Precision and Bias

11.1 The precision of this test is not known to have been obtained in accordance with currently accepted guidelines (for example, Practice D6300).^{4,8}

11.2 The precision of this test method as determined by statistical examination of interlaboratory results is as follows:

11.2.1 The difference between two test results, obtained by the same operator with the same apparatus under constant operating conditions on identical test material, would in the long run, in the normal and correct operation of the test method, exceed the following value only in one case in twenty:
0.20 mm

11.2.2 The difference between two single and independent results obtained by different operators working in different laboratories on identical test material would, in the long run, in the normal and correct operation of the test method, exceed the following value only in one case in twenty:
0.37 mm

11.3 *Bias*—The procedure in this test method for measuring wear preventing characteristics of lubricating grease has no bias because the value of wear preventing characteristics can only be defined in terms of a test method.

12. Keywords

12.1 four-ball; grease; wear

⁸ The following equipment, as listed in the submitted research report, was used to develop the precision statement and no statistically significant differences were found between these pieces of equipment: 1. Falex Corporation (formerly Roxanna Machine Works), 1020 Airpark Drive, Sugar Grove, IL 60555; 2. Precision Scientific (no longer manufactured). To date, no other equipment has demonstrated through ASTM interlaboratory testing the ability to meet the precision of this test. This is not an endorsement or certification by ASTM International.