



Designation: E2491 – 23

Standard Guide for Evaluating Performance Characteristics of Phased-Array Ultrasonic Testing Instruments and Systems¹

This standard is issued under the fixed designation E2491; the number immediately following the designation indicates the year of original adoption or, in the case of revision, the year of last revision. A number in parentheses indicates the year of last reapproval. A superscript epsilon (ϵ) indicates an editorial change since the last revision or reapproval.

1. Scope*

1.1 This guide covers procedures for evaluating some performance characteristics of phased-array ultrasonic examination instruments and systems.

1.2 Evaluation of these characteristics is intended to be used for either comparing instruments and systems or, by periodic repetition, for detecting long-term changes in the characteristics of a given instrument or system. Significant changes may be indicative of impending failure, and, if beyond certain limits, will require corrective maintenance. Some electronic instrument characteristics in phased-array units are similar to non-phased-array units and may be measured as described in Practice E1065 or Guide E1324.

1.3 Ultrasonic examination systems using pulsed-wave trains and A-scan presentation (rf or video) may be evaluated.

1.4 This guide establishes no performance limits for examination systems; if such acceptance criteria are required, these shall be specified by the using parties. Where acceptance criteria are implied herein, they are for example only and are subject to more or less restrictive limits imposed by customer's and end user's controlling documents.

1.5 The specific parameters to be evaluated, conditions, frequency of test, and report data required shall be determined by the user.

1.6 This guide may be used for the evaluation of a complete examination system, including search unit, instrument, interconnections, scanner fixtures, connected alarm, and auxiliary devices. This guide is not intended to be used as a substitute for calibration or standardization of an instrument or system to inspect any given material.

1.7 Required test apparatus includes selected test blocks and position encoders in addition to the instrument or system to be evaluated.

¹ This guide is under the jurisdiction of ASTM Committee E07 on Nondestructive Testing and is the direct responsibility of Subcommittee E07.06 on Ultrasonic Method.

Current edition approved June 1, 2023. Published August 2023. Originally approved in 2006. Last previous edition approved in 2018 as E2491 – 13 (2018). DOI: 10.1520/E2491-23.

1.8 Alternate procedures, such as examples described in this document, or others, may only be used with customer approval.

1.9 The values stated in SI units are to be regarded as standard. No other units of measurement are included in this standard.

1.10 *This standard does not purport to address all of the safety concerns, if any, associated with its use. It is the responsibility of the user of this standard to establish appropriate safety, health, and environmental practices and determine the applicability of regulatory limitations prior to use.*

1.11 *This international standard was developed in accordance with internationally recognized principles on standardization established in the Decision on Principles for the Development of International Standards, Guides and Recommendations issued by the World Trade Organization Technical Barriers to Trade (TBT) Committee.*

2. Referenced Documents

2.1 *ASTM Standards:*²

- E317 Practice for Evaluating Performance Characteristics of Ultrasonic Pulse-Echo Testing Instruments and Systems without the Use of Electronic Measurement Instruments
- E494 Practice for Measuring Ultrasonic Velocity in Materials by Comparative Pulse-Echo Method
- E1065 Practice for Evaluating Characteristics of Ultrasonic Search Units
- E1316 Terminology for Nondestructive Examinations
- E1324 Guide for Measuring Some Electronic Characteristics of Ultrasonic Testing Instruments

3. Terminology

3.1 Refer to Terminology E1316 for definitions of terms in this guide.

4. Summary of Guide

4.1 Phased-array instruments and systems have similar individual components as traditional ultrasonic systems. These

² For referenced ASTM standards, visit the ASTM website, www.astm.org, or contact ASTM Customer Service at service@astm.org. For *Annual Book of ASTM Standards* volume information, refer to the standard's Document Summary page on the ASTM website.

*A Summary of Changes section appears at the end of this standard

include pulsers, receivers, probes, and interconnecting cables. The most significant difference is that phased-array systems form the transmitted ultrasonic pulse by constructive phase interference from the wavelets formed off the individually pulsed elements of the phased-array probes.

4.2 Each phased-array probe consists of a series of individually wired elements that are activated separately using a programmable time delay pattern. Varying the number of elements used and the delay time between the pulses to each element allows control of the beam. Depending on the probe design, it is possible to electronically vary the angle (incident or skew), the focal distance, the beam dimensions, or a combination of the three. In the receiving mode, acoustic energy is received by the elements and the signals undergo a summation process utilizing the same type of time delay process as was used to generate the pulse.

4.3 The degree of beam steering available is dependent on several parameters including; number of elements, element pitch, element dimensions, element array shape, resonant frequency of the elements, the material into which the beam is directed, the minimum delay possible between firing of adjacent pulsers and receivers, and the pulser voltage characteristics.

4.4 Pulser and receiver parameters in phased-array systems are generally computer controlled and the received signals are typically displayed on computer monitors via computer data acquisition systems and may be stored to computer files.

4.5 Although most systems use piezo-electric materials for the elements, electro-magnetic acoustic transducer (EMAT) devices have also been designed and built using phased-array instrumentation.

4.6 Most phased array systems can use encoders for automated and semi-automated scanning.

4.7 Side Drilled Holes used as targets in this document should have diameters less than the wavelength of the pulse being assessed and long enough to avoid end effects from causing interfering signals. This will typically be accomplished when the hole diameter is between about 1.5 mm and 2.5 mm and 20 mm to 25 mm in length.

4.8 Procedures for assessment of several parameters in phased-array systems are described in [Annex A1 – Annex A7](#).

4.8.1 These include; determination of beam profile ([Annex A1](#)), beam steering capability ([Annex A2](#)), element activity ([Annex A3](#)), focusing capability ([Annex A4](#)), software calculations ([Annex A5](#)), compensation for wedge attenuation and delay ([Annex A6](#)), and receiver linearity ([Annex A7](#)).

5. Significance and Use

5.1 This guide is intended to evaluate performance assessment of combinations of phased-array probes and instruments. It is not intended to define performance and acceptance criteria, but rather to provide data from which such criteria may be established.

5.2 Recommended procedures described in this guide are intended to provide performance-related measurements that can be reproduced under the specified test conditions using simple targets and the phased-array test system itself. It is intended for phased-array flaw detection instruments operating in the nominal frequency range of 1 MHz to 20 MHz, but the procedures are applicable to measurements on instruments utilizing significantly higher frequency components.

5.3 This guide is not intended for service calibration, or maintenance of circuitry for which the manufacturer's instructions are available.

5.4 Implementation of specific assessments may require more detailed procedural instructions in a format of the using facility.

5.5 The measurement data obtained may be employed by users of this guide to specify, describe, or provide performance criteria for procurement and quality assurance, or service evaluation of the operating characteristics of phased-array systems.

5.6 Not all assessments described in this guide are applicable to all systems. All or portions of the guide may be used as determined by the user.

6. Keywords

6.1 characterization; focal point; phased-array; phased-array probe; sound beam profile; ultrasound

ANNEXES

(Mandatory Information)

A1. DETERMINATION OF PHASED-ARRAY BEAM PROFILE

A1.1 Introduction

A1.1.1 This annex describes procedures to determine beam profiles of phased-array probes. Either immersion or contact probe applications can be addressed using these procedures. However, it should be cautioned that assessments of contact probes may suffer from variability greater than imposed tolerances if proper precautions are not taken to ensure constant coupling conditions.

A1.2 Test Setup

A1.2.1 For single focal laws where the beam is fixed (that is, not used in an electronic or sectorial scan mode) and the probe is used in an immersion setup, the ball-target or hydrophone options described in Practice E1065 may be used. For phased array probes used in a dynamic fashion where several focal laws are used to produce sectorial or electronic scanning it may be possible to make beam-profile assessments with no or little mechanical motion. Where mechanical motion is used it shall be encoded to relate signal time and amplitude to distance moved. Encoder accuracy shall be verified to be within tolerances appropriate for the measurements made. Descriptions made for electronic scan and sectorial scan beam profile assessments will be made for contact probes; however, when assessment in water is required the machined targets may be replaced with rods or balls as appropriate.

A1.2.2 *Linear-Array Probes*—Assessment of the beam in the active plane should be made by use of an electronic scan sequence. For phased array probes using a large portion of the

available elements to form the beam the number of remaining elements for the electronic raster may be too small to allow the beam to pass over the target. In this case, it will be necessary to have encoded mechanical motion and assess each focal law along the active plane separately.

A1.2.3 Side drilled holes should be arranged at various depths in a flaw-free sample of the test material in which focal laws have been programmed for. Using the linear scan feature of the phased-array system the beam is passed over the targets at the various depths of interest. The electronic scan is illustrated schematically in Fig. A1.1.

A1.2.4 Data collection of the entire waveform over the range of interest shall be made. The display shall represent amplitude as a color or grayscale. Time or equivalent distance in the test material shall be presented along one axis and distance displaced along the other axis. This is a typical B-scan as illustrated in Fig. A1.2.

A1.2.5 Data display for an electronic scan using a phased-array probe mounted on a wedge can be similarly made using simple orthogonal representation of time versus displacement or it can be angle-corrected as illustrated in Fig. A1.3.

A1.2.6 Resolution along the displacement axis will be a function of the scan increment of the electronic scan or, if the scan uses an encoded mechanical fixture the resolution, will be dependent on the encoder step-size used for sampling.

A1.2.7 Resolution along the beam axis will be a function of the intervals between the target paths. For highly focused

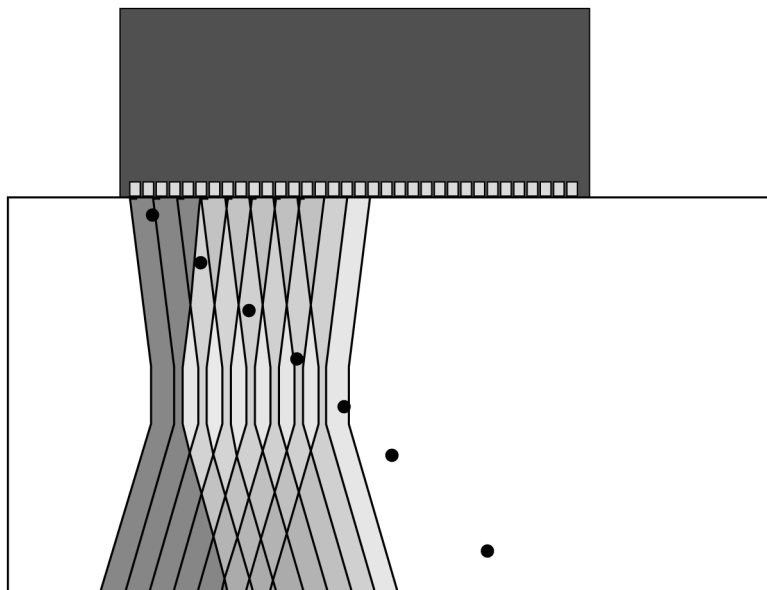

FIG. A1.1 Electronic Scan of Side Drilled Holes

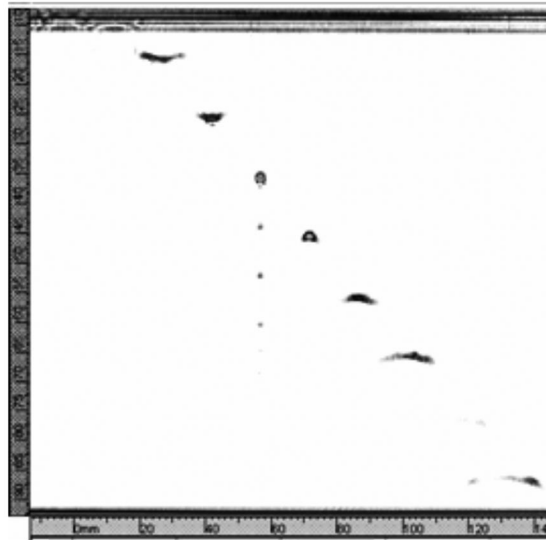

FIG. A1.2 B-Scan Display of Electronic Scan Represented in Fig. A1.1 (Depth is in the vertical axis and electronic-scan distance is represented along the horizontal axis.)

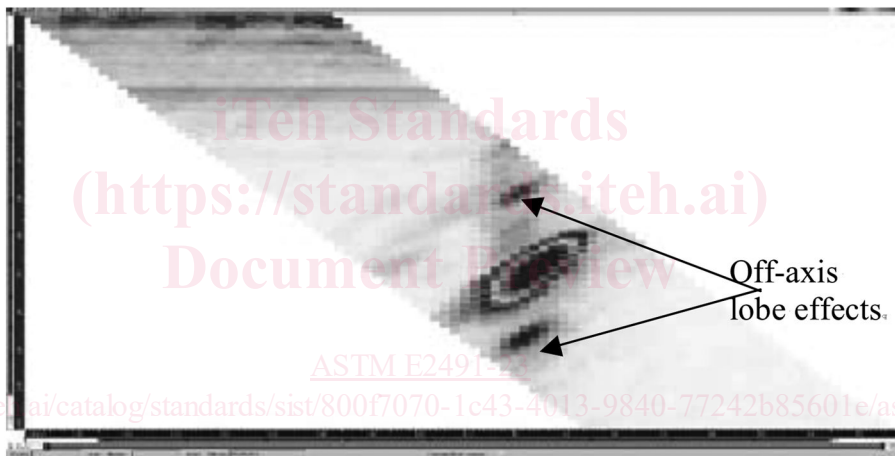

FIG. A1.3 Angle-Corrected B-Scan of a Phased-Array Beam (in Shear Wave Mode) from a Side Drilled Hole (Off-axis lobe effects can be seen in the display.)

beams it may be desirable to have small differences between the sound paths to the target paths (for example, 1 mm or 2 mm).

A1.2.8 Beam profiling in the passive plane should also be made, which will require mechanical scanning.

A1.2.9 Waveform collection of signals using a combination of electronic scanning in the active plane and encoded mechanical motion in the passive plane provides data that can be projection-corrected to provide beam dimensions in the passive plane. Fig. A1.4 illustrates a method for beam assessment in the passive plane. This technique uses a corner reflection from an end-drilled hole at depths established by a series of steps.

A1.2.10 Fig. A1.5 illustrates an alternative to the stepped intervals shown in Fig. A1.4. A through hole may be arranged perpendicular to the required refracted angle to provide a continuous transition of path length to the target.

A1.2.11 A projected C-scan can be used to size the beam based on either color or grayscale indicating amplitude drop or a computer display that plots amplitude with respect to displacement. The projected C-scan option is schematically represented in Fig. A1.6.

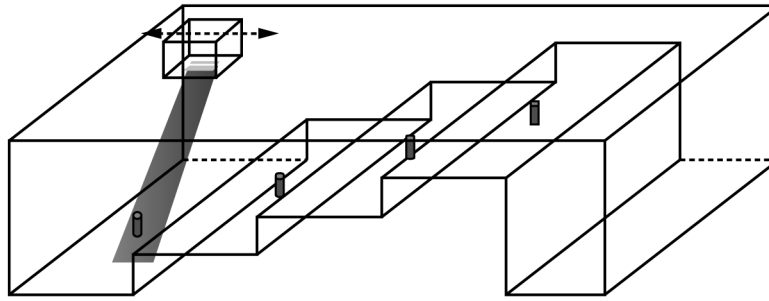

FIG. A1.4 Scanning End-Drilled Holes to Obtain Beam Dimensions in Passive Plane

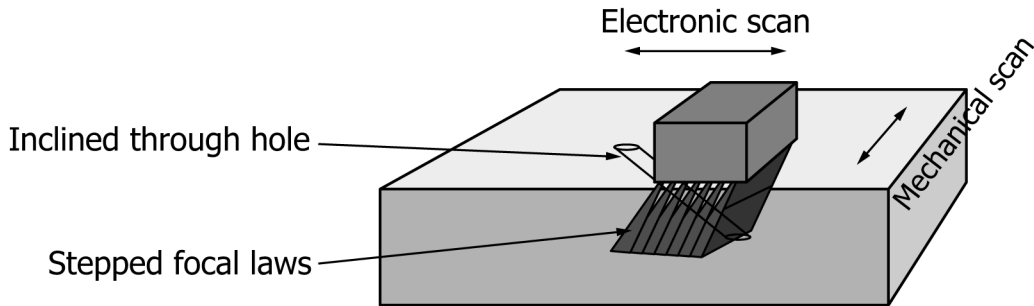

FIG. A1.5 Representation of an Inclined Hole for Beam Characterization in the Passive Plane

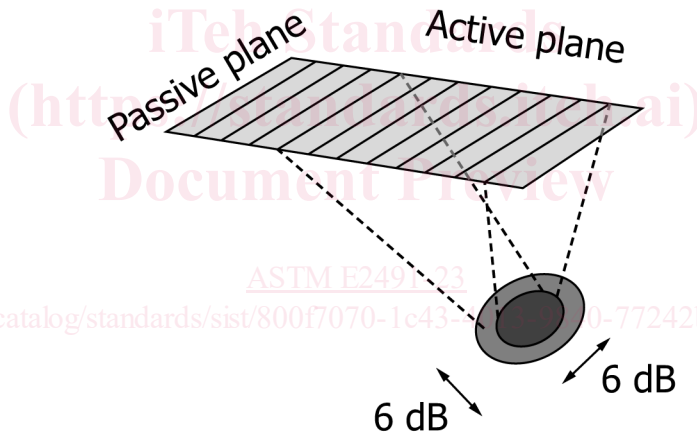

FIG. A1.6 Representation of Projected C-Scan of Corner Effect Scan Seen in Fig. A1.4

A2. DETERMINATION OF PHASED-ARRAY BEAM STEERING LIMITS

A2.1 Introduction

A2.1.1 This annex describes procedures to determine practical limits for beam steering capabilities of a phased-array probe and as such applies to the active plane(s) only. Either immersion or contact probe applications can be addressed using these procedures. However, it should be cautioned that assessments of contact probes may suffer from variability greater than imposed tolerances if proper precautions are not taken to ensure constant coupling conditions.

A2.1.2 Recommended limits to establish the working range of angular sweep of a phased-array probe relate to the divergence of the beam of each element in the probe array. When used in pulse-echo mode the steering limit is considered to be within the 6 dB divergence envelope of the individual elements. It is therefore possible to calculate a theoretical limit based on nominal frequency and manufacturer provided information on the element dimensions.

A2.1.3 Several parameters can affect the theoretical calculations. These are primarily related to the nominal frequency of the probe. Some parameters affecting actual frequency include; pulse length, damping, use of a delay-line or refracting wedge, and variations in manufacturing processes on thickness lapping and matching layers. Beam steering capability will also be affected by project requirements of the beam. Applications where focusing is necessary may not achieve the same limits as applications where the beam is not focused as well as steered.

A2.1.4 Steering capability may be specific to a sound path distance, aperture, and material. For the purposes of this procedure, assessment of beam steering capability will be based on a comparison of signal to noise ratios at varying angular displacements.

A2.2 *Test Set-Up*—Configure the probe focal laws for the conditions of the test. This will include immersion or contact, refracting wedge or delay-line, unfocused or a defined focal distance, and the test material to be used.

A2.2.1 Prepare a series of side drilled holes in the material to be used for the application at the distance or distances to be used in the application. The side-drilled-hole pattern should be as illustrated in Fig. A2.1. Holes indicated in Fig. A2.1 are at 5° intervals at a 25 mm and 50 mm distance from a center where the probe is located.

A2.2.2 Similar assessments are possible for different applications. When a set of focal laws is arranged to provide resolution in a plane instead of a sound path distance, the plane of interest may be used to assess the steering limits of the beam. The block used for assessment would be arranged with side drilled holes in the plane of interest. Such a plane-specific block is illustrated in Fig. A2.2 where a series of holes is made in a vertical and horizontal plane at a specified distance from

the nominal exit point. Side drilled holes may be arranged in other planes (angles) of interest.

A2.2.3 Assessments are made placing the probe such that the center of beam ray (as determined by measuring the beam exit point) enters the block at the indicated centerline. For analysis of a probe where all the elements in a single plane are used without a delay line or refracting wedge, the midpoint of the element array shall be aligned with the centerline. For focal laws using only a portion of the total available elements, the midpoint of the element aperture shall be aligned with the centerline. When delay lines, refracting wedges, or immersion methods are used, corrections will be required to compensate for movement of the “apparent” exit point along the block entry surface. When a probe is used in direct contact with a verification block as illustrated in Fig. A2.2, the lack of symmetry either side of the centerline prevents both positive and negative sweep angles being assessed simultaneously. To assess the sweep limit in the two directions when using this style of block requires that the probe be assessed in one direction first and then rotated 180° and the opposite sweep assessed.

A2.2.4 Angular steps between A-scan samples will have an effect on the perceived sweep limits. A maximum of 1° between S-scan samples is recommended for steering assessment. Angular steps are limited by the system timing-delay capabilities between pulses and element pitch characteristics. Most of the targets illustrated in Fig. A2.1 and Fig. A2.2 are separated by 5°; however, greater or lesser intervals may be used depending on the required resolution.

A2.2.5 Assessment of steering limits shall be made using the dB difference between the maximum and minimum signal amplitudes between two adjacent side drilled holes. For

<https://standards.iteh.ai/catalog/standards/sist/800f7070-1c43-4013-9840-77242b85601e/astm-e2491-23>

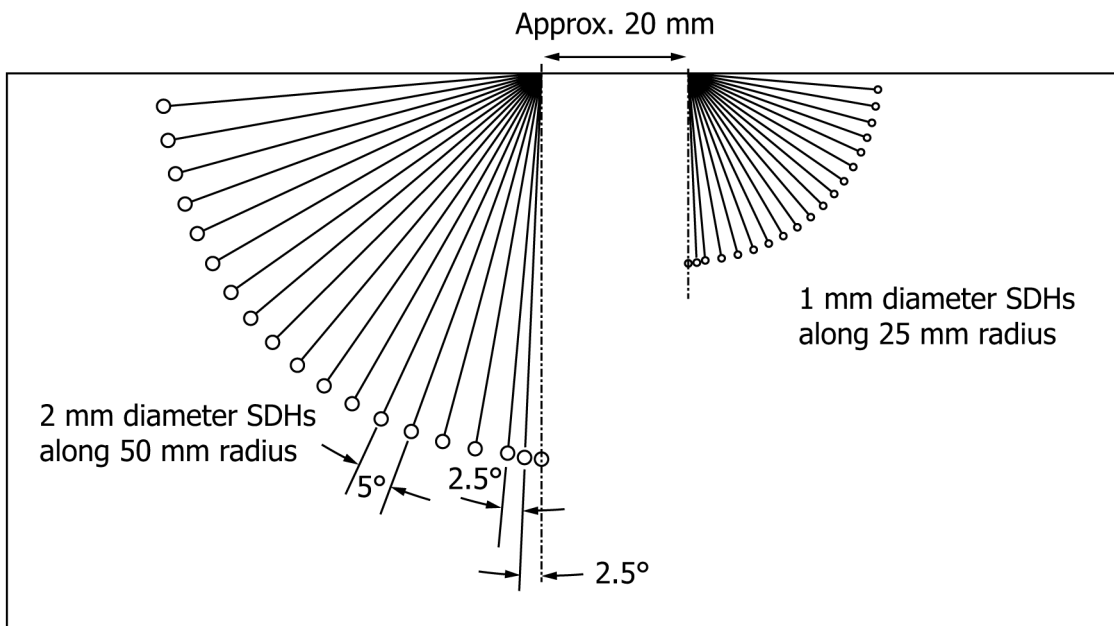

NOTE 1—Block dimensions 150 mm by 75 mm by 25 mm (typical)
FIG. A2.1 Beam Steering Assessment Block—Constant Sound Path

Vertical plane 50 mm from exit point

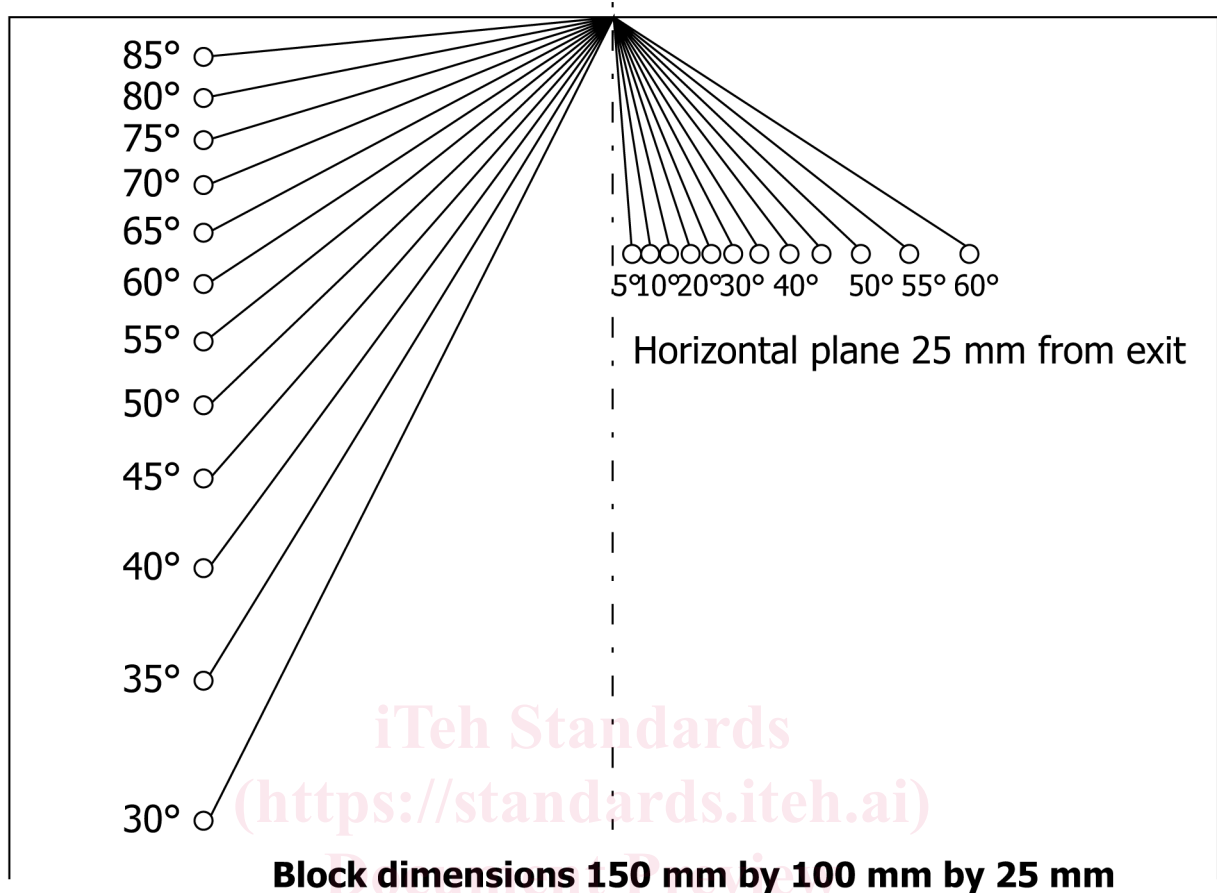

FIG. A2.2 Beam Steering Assessment Block—Single Plane

example, when a phased-array probe is configured to sweep +45° from the beam centerline on a block such as illustrated in Fig. A2.1, the highest of the SDHs which achieves a 6 dB amplitude may be considered the maximum steering capability of the probe configuration.

A2.2.6 Acceptable limits of steering may be indicated by the maximum and minimum angles that can achieve a pre-specified separation between adjacent holes. Depending on the application a 6 dB or 20 dB (or some other value) may be specified as the required separation.

A2.2.7 Steering capabilities may be used as a prerequisite; for example, a phased-array system is required to achieve a minimum steering capability for 5° resolution of 2 mm diameter side drilled holes of plus and minus 20° from a nominal

mid-angle. Conversely, a system may be limited to S-scans not exceeding the angles assessed to achieve a specified signal separation, for example, -20 dB between 2 mm diameter SDHs separated by 5°.

A2.3 An alternative assessment may use a single SDH at a specified depth or sound path distance. Displaying the A-scan for the maximum and minimum angles used would assess the steering capability by observing the S/N ratio at the peaked response. Steering limit would be a pre-defined S/N ratio being achieved. Caution must be taken when using this method so as to not peak on grating lobe signals. This method will also require confirmation that the SDH is positioned at the calculated refracted angle.