



Standard Test Method for Calibration of Refractory Metal Thermocouples Using a Radiation Thermometer¹

This standard is issued under the fixed designation E452; the number immediately following the designation indicates the year of original adoption or, in the case of revision, the year of last revision. A number in parentheses indicates the year of last reapproval. A superscript epsilon (ϵ) indicates an editorial change since the last revision or reapproval.

1. Scope

1.1 This test method covers the calibration of refractory metal thermocouples using a radiation thermometer as the standard instrument. This test method is intended for use with types of thermocouples that cannot be exposed to an oxidizing atmosphere. These procedures are appropriate for thermocouple calibrations at temperatures above 800 °C (1472 °F).

1.2 The calibration method is applicable to the following thermocouple assemblies:

1.2.1 *Type 1*—Bare-wire thermocouple assemblies in which vacuum or an inert or reducing gas is the only electrical insulating medium between the thermoelements.

1.2.2 *Type 2*—Assemblies in which loose fitting ceramic insulating pieces, such as single-bore or double-bore tubes, are placed over the thermoelements.

1.2.3 *Type 2A*—Assemblies in which loose fitting ceramic insulating pieces, such as single-bore or double-bore tubes, are placed over the thermoelements, permanently enclosed and sealed in a loose fitting metal or ceramic tube.

1.2.4 *Type 3*—Swaged assemblies in which a refractory insulating powder is compressed around the thermoelements and encased in a thin-walled tube or sheath made of a high melting point metal or alloy.

1.2.5 *Type 4*—Thermocouple assemblies in which one thermoelement is in the shape of a closed-end protection tube and the other thermoelement is a solid wire or rod that is coaxially supported inside the closed-end tube. The space between the two thermoelements can be filled with an inert or reducing gas, or with ceramic insulating materials, or kept under vacuum.

1.3 *This standard does not purport to address all of the safety concerns, if any, associated with its use. It is the responsibility of the user of this standard to establish appropriate safety, health, and environmental practices and determine the applicability of regulatory limitations prior to use.*

1.4 *This international standard was developed in accordance with internationally recognized principles on standard-*

ization established in the Decision on Principles for the Development of International Standards, Guides and Recommendations issued by the World Trade Organization Technical Barriers to Trade (TBT) Committee.

2. Referenced Documents

2.1 *ASTM Standards:*²

[E344 Terminology Relating to Thermometry and Hydrometry](#)

[E563 Practice for Preparation and Use of an Ice-Point Bath as a Reference Temperature](#)

[E988 Temperature-Electromotive Force \(EMF\) Tables for Tungsten-Rhenium Thermocouples \(Withdrawn 2011\)](#)³

[E1256 Test Methods for Radiation Thermometers \(Single Waveband Type\)](#)

[E1751 Guide for Temperature Electromotive Force \(emf\) Tables for Non-Letter Designated Thermocouple Combinations](#)

3. Terminology

3.1 *Definitions:*

3.1.1 For definitions of terms used in this test method see Terminology [E344](#).

3.1.2 *radiation thermometer, n*—radiometer calibrated to indicate the temperature of a blackbody.

3.1.2.1 *Discussion*—Radiation thermometers include instruments having the following or similar names: (1) optical radiation thermometer, (2) photoelectric pyrometer, (3) single wavelength automatic thermometer, (4) disappearing filament pyrometer, (5) dual wavelength pyrometer or ratio radiation thermometer, (6) visual optical thermometer, (7) infrared thermometer, (8) infrared pyrometer, and permutations on the terms above as well as some manufacturer-specific names.

3.2 *Definitions of Terms Specific to This Standard:*

3.2.1 *automatic radiation thermometer, n*—radiation thermometer whose temperature reading is determined by electronic means.

¹ This test method is under the jurisdiction of ASTM Committee E20 on Temperature Measurement and is the direct responsibility of Subcommittee E20.11 on Thermocouples - Calibration.

Current edition approved Aug. 15, 2023. Published August 2023. Originally approved in 1972. Last previous edition approved in 2018 as E452 – 02 (2018). DOI: 10.1520/E0452-02R23.

² For referenced ASTM standards, visit the ASTM website, www.astm.org, or contact ASTM Customer Service at service@astm.org. For *Annual Book of ASTM Standards* volume information, refer to the standard's Document Summary page on the ASTM website.

³ The last approved version of this historical standard is referenced on www.astm.org.

3.2.2 *disappearing filament pyrometer, n*—radiation thermometer that requires an observer to match visually the brightness of a heated filament mounted inside the radiation thermometer to that of the measured object.

3.2.3 *equalizing block, n*—object, usually metal, that when placed in a nonuniform temperature region, has greater temperature uniformity (due to its relatively high thermoconductivity and mass) than the medium surrounding the object.

3.2.4 *spectral emissivity, n*—ratio of the spectral radiance at a point on a particular specimen and in a particular direction from that point to that emitted by a blackbody at the same temperature.

3.2.5 *spectral radiance, n*—power radiated by a specimen in a particular direction, per unit wavelength, per unit projected area of the specimen, and per unit solid angle.

3.2.6 *spectral response, n*—signal detected by a radiometer at a particular wavelength of incident radiation, per unit power of incident radiation.

3.2.7 *test thermocouple, n*—thermocouple that is to have its temperature-emf relationship determined by reference to a temperature standard.

3.2.8 *thermocouple calibration point, n*—temperature, established by a standard, at which the emf developed by a thermocouple is determined.

4. Summary of Test Method

4.1 The thermocouple is calibrated by determining the temperature of its measuring junction with a radiation thermometer and recording the emf of the thermocouple at that temperature. The measuring junction of the thermocouple is placed in an equalizing block containing a cavity which approximates blackbody conditions. The radiation thermometer is sighted on the cavity in the equalizing block and the blackbody temperature or true temperature of the block, including the measuring junction, is determined.

4.2 Since the spectral emissivity of the radiation emanating from a properly designed blackbody is considered unity (one) for all practical purposes, no spectral emissivity corrections need be applied to optical pyrometer determinations of the blackbody temperature.

4.3 Although the use of a radiation thermometer (**Note 1**) is less may require more effort and more complex apparatus to achieve a sensitivity equivalent to that of commonly used thermocouples, a radiation thermometer has the advantage of being physically separated from the test assembly; thus, its calibration is not influenced by the temperatures and atmospheres in the test chamber. By comparison, a standard thermocouple that is used to calibrate another thermocouple must be subjected to the temperatures at which the calibrations are performed and in some cases must be exposed to the environment that is common to the test thermocouple. If a standard thermocouple is exposed to high temperatures or contaminating environments, or both, for long periods of time, its calibration becomes questionable and the uncertainty in the bias of the calibration increases.

NOTE 1—Disappearing filament pyrometers are somewhat less sensitive

than many of the thermocouples used above 800 °C (1472 °F). The advantages of physical separation of the disappearing filament pyrometer from the test assembly may still justify its use over use of a standard thermocouple.

5. Significance and Use

5.1 This test method is intended to be used by wire producers and thermocouple manufacturers for certification of refractory metal thermocouples. It is intended to provide a consistent method for calibration of refractory metal thermocouples referenced to a calibrated radiation thermometer. Uncertainty in calibration and operation of the radiation thermometer, and proper construction and use of the test furnace are of primary importance.

5.2 Calibration establishes the temperature-emf relationship for a particular thermocouple under a specific temperature and chemical environment. However, during high temperature calibration or application at elevated temperatures in vacuum, oxidizing, reducing or contaminating environments, and depending on temperature distribution, local irreversible changes may occur in the Seebeck Coefficient of one or both thermoelements. If the introduced inhomogeneities are significant, the emf from the thermocouple will depend on the distribution of temperature between the measuring and reference junctions.

5.3 At high temperatures, the accuracy of refractory metal thermocouples may be limited by electrical shunting errors through the ceramic insulators of the thermocouple assembly. This effect may be reduced by careful choice of the insulator material, but above approximately 2100 °C, the electrical shunting errors may be significant even for the best insulators available.

6. Sources of Error

6.1 The most prevalent sources of error (**Note 2**) in this method of calibration are: (1) improper design of the blackbody enclosure, (2) severe temperature gradients in the vicinity of the blackbody enclosure, (3) heat conduction losses along the thermoelements, and (4) improper alignment of the radiation thermometer with respect to the blackbody cavity and unaccounted transmission losses along the optical path of the radiation thermometer.

NOTE 2—These are exclusive of any errors that are made in the radiation thermometer measurements or the thermocouple-emf measurements.

7. Apparatus

7.1 Furnace:

7.1.1 The calibration furnace should be designed so that any temperature within the desired calibration temperature range can be maintained constant within a maximum change of 1 °C (1.8 °F) per minute in the equalizing block over the period of any observation. **Figs. 1-3** show three types of furnaces (**1 and 2**)⁴ that can be used for calibrating refractory-metal thermocouples. **Fig. 4** is a detailed drawing of the upper section of the furnace in **Fig. 3**. An equalizing block containing a blackbody

⁴ The boldface numbers in parentheses refer to the list of references at the end of this standard.

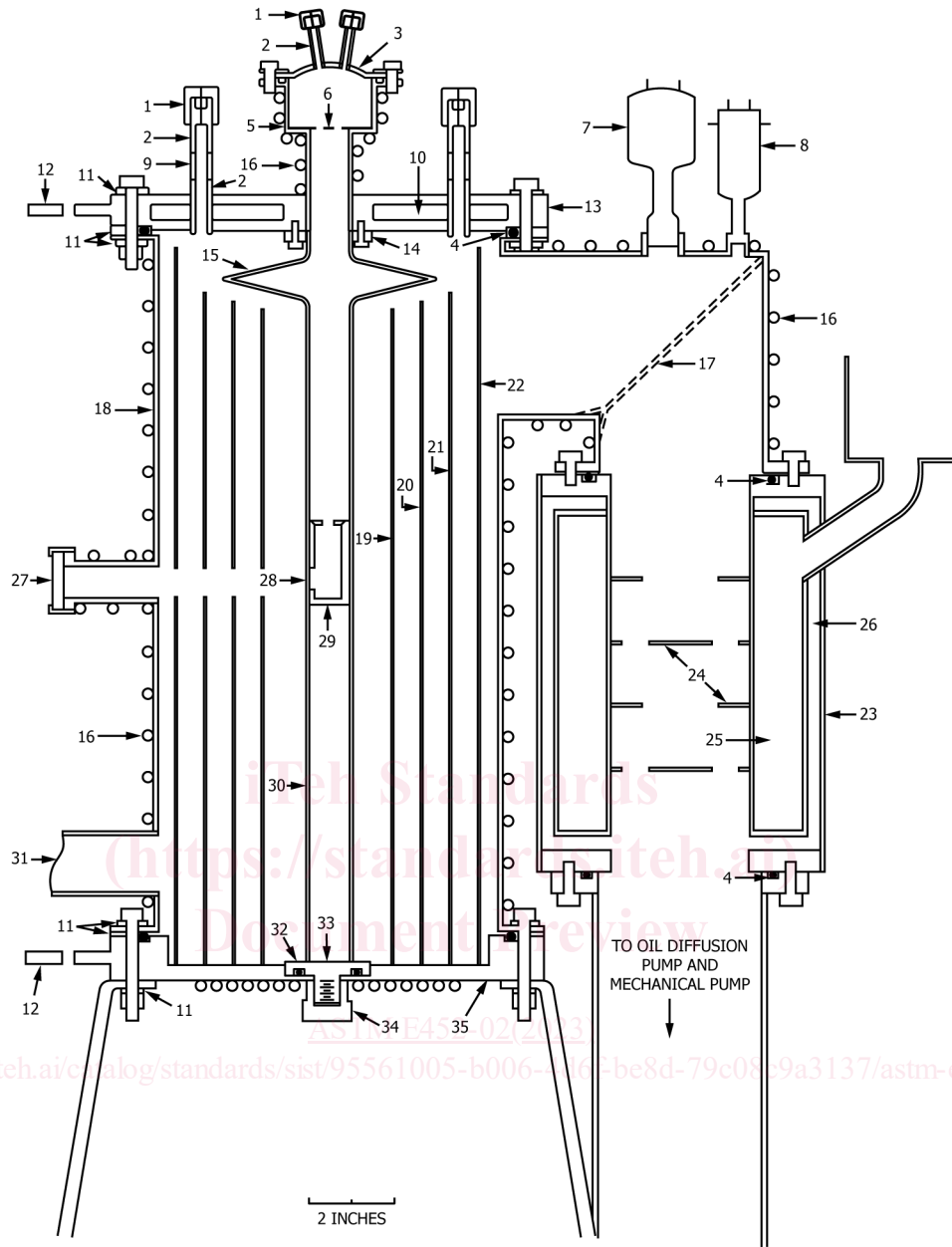

- | | |
|--|--|
| <ol style="list-style-type: none"> 1. Caps for making vacuum tight seals around the thermoelements. A cylinder type neoprene gasket is compressed around the thermoelements. 2. Kovar metal tube. 3. Dome made of No. 7052 glass providing electrical insulation for thermoelements. 4. Neoprene O-ring gasket. 5. Top plate extension (brass). 6. Aluminum oxide radiation shield. 7. Ionization vacuum gage. 8. Thermocouple vacuum gage. 9. No. 7052 glass tube providing electrical insulation for thermoelements. 10. Chamber for water flow during furnace operation. 11. Electrically insulating spacers. 12. Power supply terminal. 13. Removable top plate (brass). 14. Tantalum spacing ring providing electrical contact between plate and tantalum tube. 15. Thermal expansion joint of tantalum tube. 16. Copper tubing for water cooling. 17. Auxiliary radiation shield. | <ol style="list-style-type: none"> 18. Furnace shell (brass). 19. First radiation shield. 0.020-in. (0.51 mm) tantalum sheet rolled into a cylinder and secured with tantalum rivets. 20. Second radiation shield. (0.020-in. (0.51 mm) molybdenum.) 21. Third radiation solid. (0.020-in. (0.51 mm) molybdenum.) 22. Fourth radiation shield. (0.010-in. (0.25 mm) molybdenum.) 23. Liquid nitrogen trap. 24. Metal baffle plates at liquid nitrogen temperature. 25. Liquid nitrogen chamber. 26. Vacuum chamber. 27. Borosilicate glass window. 28. Hole (0.045-in. (1.14 mm) diameter) for sighting with disappearing filament pyrometer. 29. Molybdenum blackbody. 30. Tantalum tube. 31. Inert gas entrance. 32. Tantalum rings for electrical contact. 33. Removable copper plate for electrical contact. 34. Hex-head nut for tightening copper plate against O-ring gasket. 35. Bottom plate (brass). |
|--|--|

FIG. 1 High-Temperature Furnace (Example 1)

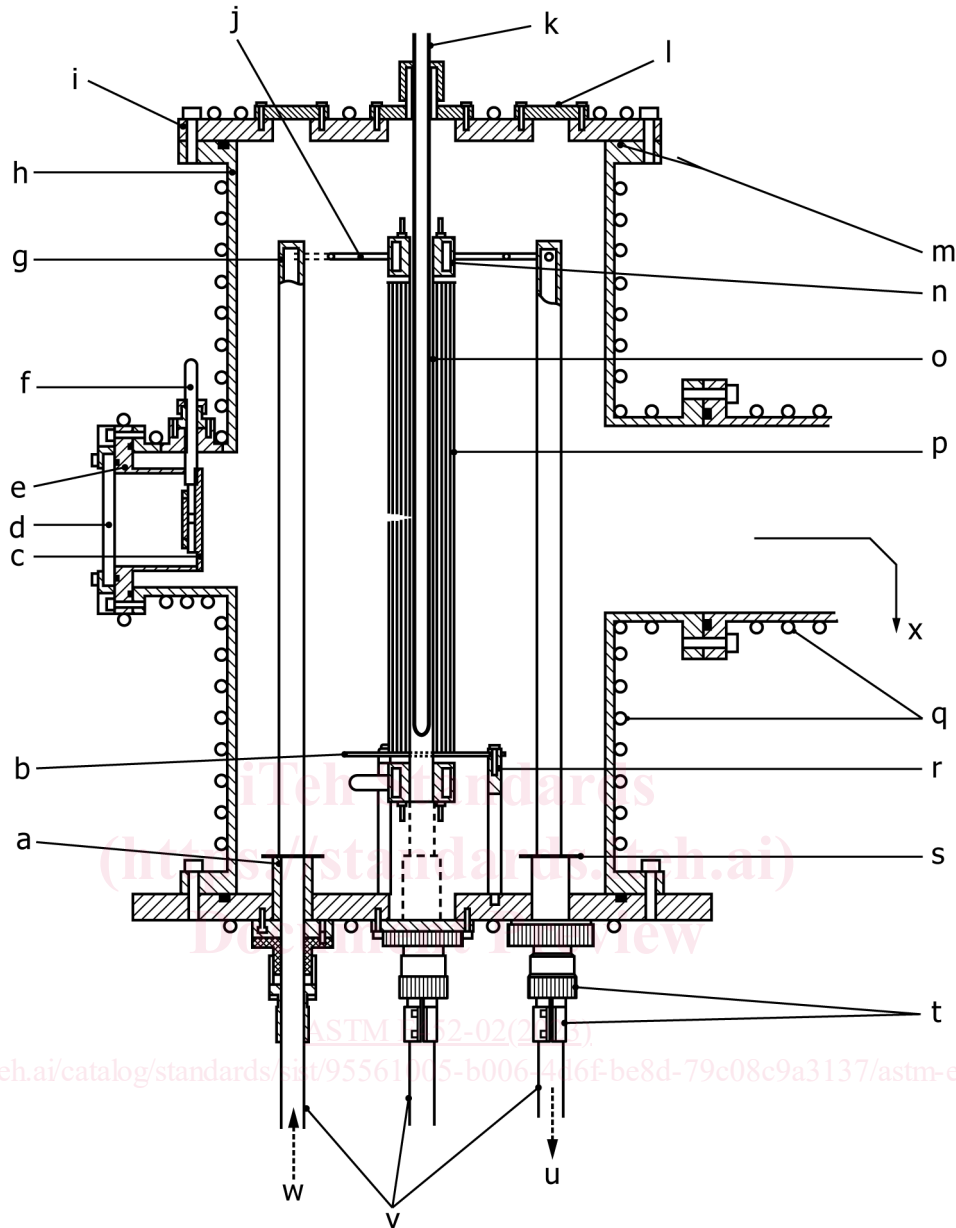

(a) Nylon bushing, (b) stainless steel support, (c) rectangular stainless steel shutter, (d) borosilicate glass window, (e) brass shutter support, (f) shutter rotation mechanism, (g) copper lead, (h) steel housing, (l) brass plate, (j) copper coil spring, (k) alumina closed-end tube, (l) port, (m) O-ring gaskets, (n) copper water-cooled electrode, (o) tantalum heater element, (p) tantalum radiation shields, (q) water-cooling coils, (r) ceramic insulator, (s) tantalum radiation shield, (t) adjustable clamp, (u) water out, (v) electrical leads, (w) water in, and (x) to vacuum system.

FIG. 2 High-Temperature Furnace (Example 2)

cavity is suspended in the central region of the furnace by means of support rods or wires. The mass of the support rods or wires should be kept to a minimum to reduce heat losses by conduction. When the furnace is in operation, a sufficiently large region in the center of the furnace should be at a uniform temperature to ensure that the temperature throughout the equalizing block (when all test thermocouple assemblies are in position in the block) is uniform. At temperatures greater than 2000 °C, furnace parts made from tantalum may introduce contamination of exposed thermoelements. In this case, it may be desirable to fabricate heated furnace components from tungsten.

7.1.2 The blackbody cavity in the equalizing block should be designed in accordance with established criteria set forth in the literature (3-7). Such factors as interior surface texture, diameter-to-depth ratio of the blackbody cavity opening, and internal geometry can have an appreciable effect on the spectral emissivity of the cavity.

7.1.3 Figs. 5-7 show three typical equalizing block designs that are used in thermocouple calibrating furnaces. The design in Fig. 5 is used in furnaces where the standard radiation thermometer is sighted horizontally into the blackbody through the hole in the side of the block. This design is particularly useful in the calibration of bare-wire thermocouples since the

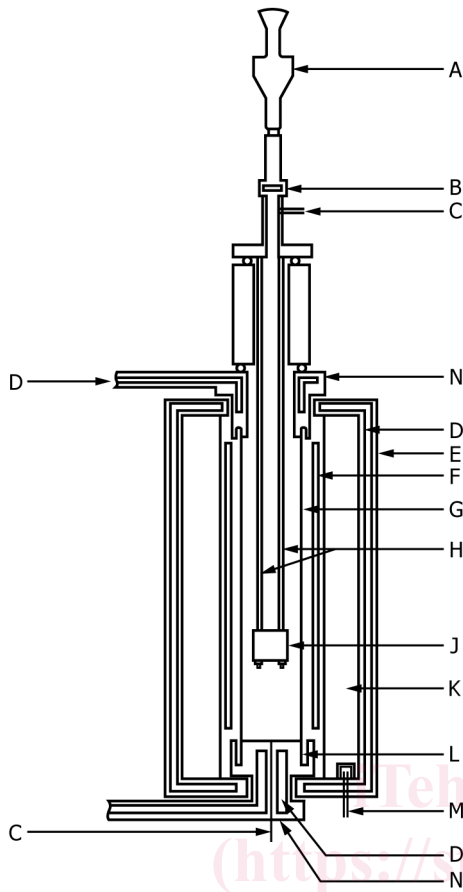

- (A) Disappearing filament pyrometer
- (B) Sight window
- (C) Gas inlet
- (D) Water cooling
- (E) Stainless steel shell
- (F) Tungsten heat shield
- (G) Tungsten heater
- (H) Support rods
- (J) Equalizer block (blackbody)
- (K) Refractory brick
- (L) Gallium alloy electrical contact
- (M) Gas outlet
- (N) Copper electrode

FIG. 3 High-Temperature Furnace (Example 3)

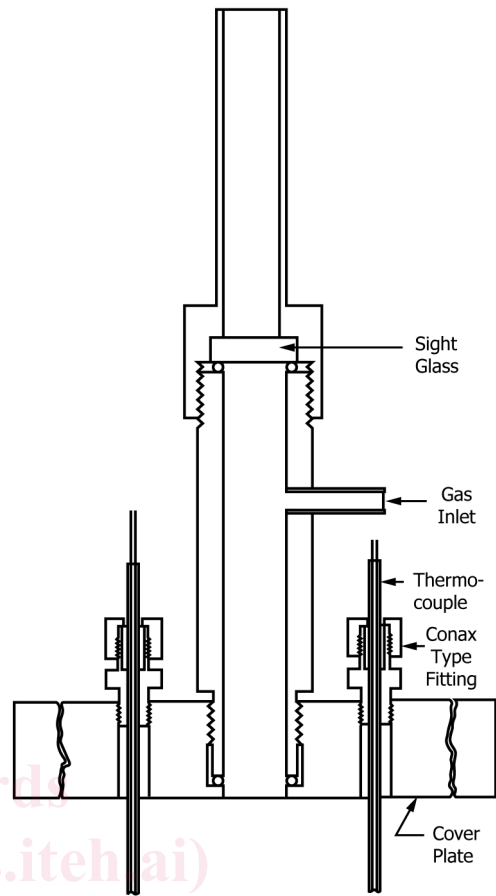

FIG. 4 Upper Section of Furnace (Example 3)

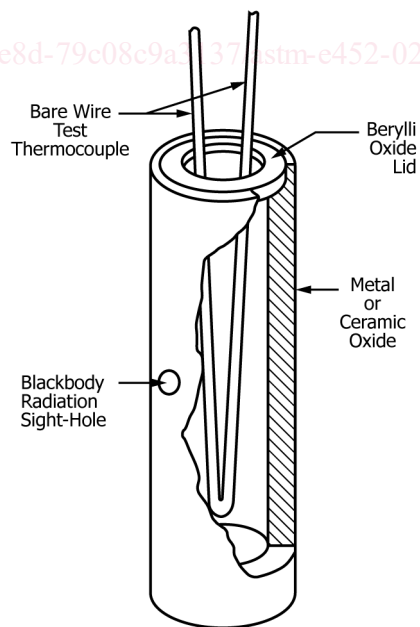

FIG. 5 Equalizing Block (Example A)

lid on the blackbody (or the entire blackbody) can be an electrically insulating material such as hafnium oxide or beryllium oxide. Thus, if the bare thermocouple wires should come in contact with the equalizing block, the wires will not be electrically shorted. If this design is used in the calibration of Types 2, 3, or 4 thermocouple assemblies (see 1.2), the blackbody lid can be metal since electrical insulation between the thermoelements is included as part of the assembly. **(Warning—**Beryllium oxide should be considered a hazardous material. Material Safety Data Sheets and precautions in handling this toxic substance should be obtained from the supplier.)

7.1.4 The designs in Figs. 6 and 7 are used in furnaces where the standard radiation thermometer is sighted vertically into the blackbody cavity. In cases where it is necessary to

calibrate a number of thermocouples during one calibration run or to calibrate thermocouple assemblies that are large in

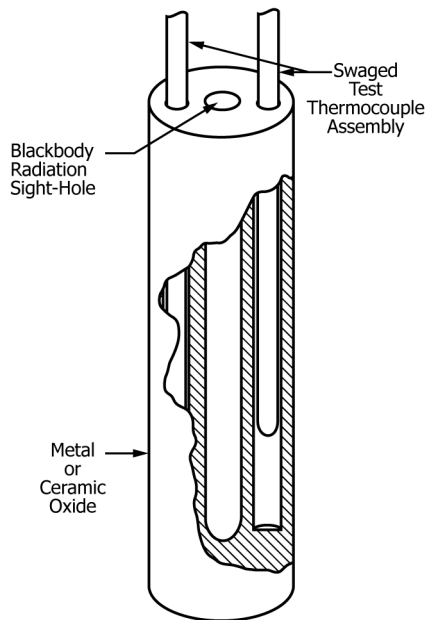

FIG. 6 Equalizing Block (Example B)

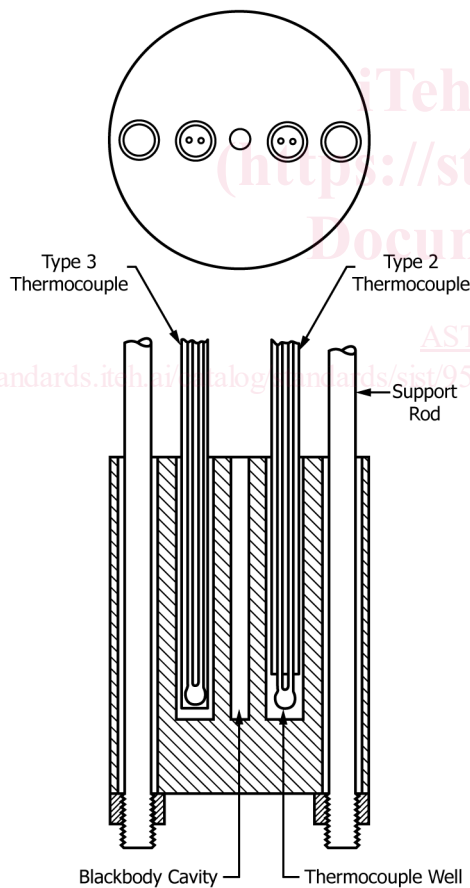

FIG. 7 Equalizing Block (Example C)

diameter and mass, the equalizing block designs in Figs. 6 and 7 are appropriate. If the thermocouple assemblies being tested in these types of equalizing blocks are massive and can conduct a considerable amount of heat away from the block, the

blackbody cavity and the thermocouple wells should be of sufficient depth to ensure that the thermocouple measuring junctions and a considerable length of the thermocouple assemblies leading from the measuring junctions are contained in the wall of the equalizing block.

7.1.5 In order to view the radiation emanating from the blackbody cavity, some type of window shall be contained in the outer structure of the furnace. It is important that this window be properly designed to ensure that errors are not encountered when the blackbody radiation is observed with a radiation thermometer. Windows may be made from any transparent glass or crystalline material of high optical quality.

7.1.6 Figs. 8 and 9 show an incorrectly designed furnace window and a correctly designed window, respectively. In Fig. 8 the blackbody radiation emanating from the window does not completely fill the objective lens of the radiation thermometer. This is caused by the window opening being too small in diameter and thus acting as an aperture stop. In this case, the temperature indicated by the radiation thermometer may be lower than the temperature indicated if all of the objective lens is filled with the cone of radiation. Fig. 9 shows a larger window opening with the resulting cone of radiation completely filling the objective lens. It also can be seen that the openings in the radiation shields can act as aperture stops if they are too small in diameter. This may cause the same type of error as described with the window opening. On the other hand, if the window and the radiation shield openings are made too large, radiation losses may produce appreciable temperature gradients in the hot zone of the furnace.

7.1.7 The transmission losses of the window should be determined at all calibration temperatures and the appropriate corrections applied to all radiation thermometer readings (see 8.3).

7.1.8 Figs. 10 and 11 show two types of vacuum seals (Note 3) that can be used to bring test thermocouple assemblies into the furnace chamber. The seal shown in Fig. 10 is particularly useful for bringing bare-wire thermocouples into the furnace. This design makes use of a cylinder-shaped fluorocarbon gasket that is compressed around the thermocouple wires to form a vacuum tight seal. A small amount of high-temperature vacuum grease should be placed on each gasket before sealing. The thermocouple wires are inserted through a coaxial hole in the gasket. Also, this design can be used to form a seal around the outer sheath of swaged thermocouple assemblies (Type 3 of 1.2).

NOTE 3—If the calibration furnace design is such that the desired furnace atmosphere is obtained by purging (see 8.2), vacuum seals are not needed to maintain a relatively pure furnace atmosphere.

7.1.9 The seal shown in Fig. 11 can be used in arrangements where many test thermocouples are inserted and removed from the furnace chamber over a short period of time. This design allows the test thermocouple to be quickly attached to or detached from extension wires that are permanently sealed in the metal-to-glass sealing unit. When a test thermocouple is to be removed from the furnace, the O-ring gasket seal (Seal A) is broken and the top section of the seal is lifted upward, thus lifting the attached test thermocouple out of the furnace.

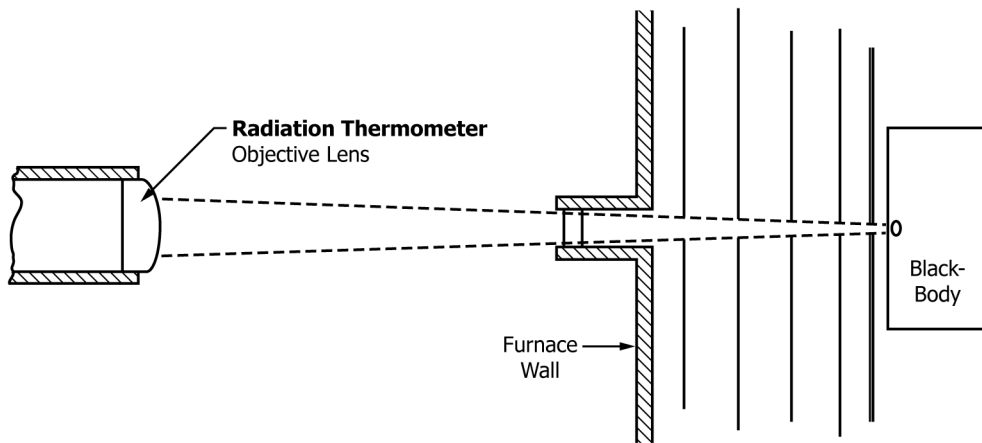

FIG. 8 Furnace Window (Incorrect Design)

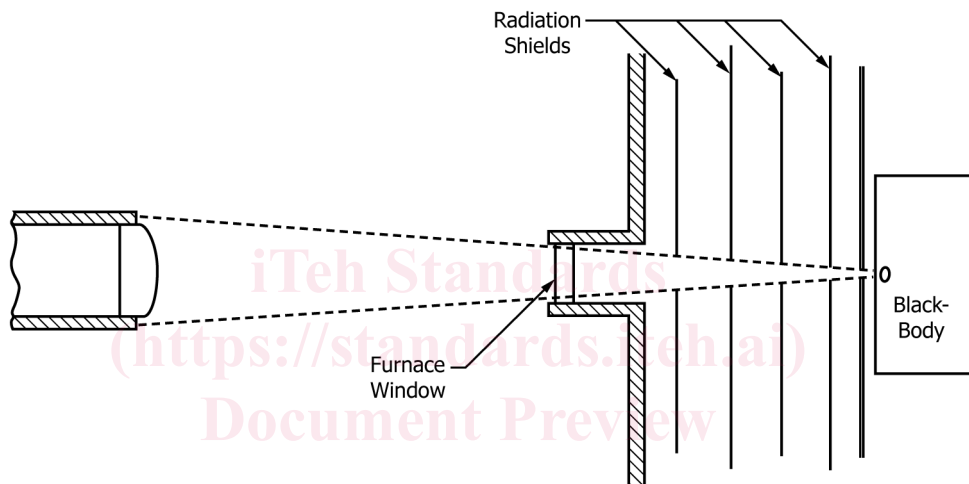

FIG. 9 Furnace Window (Correct Design)

NOTE 1—It should be recognized that errors resulting from incorrect furnace window design may be more significant for single wavelength automatic radiation thermometers than either disappearing filament pyrometers or dual wavelength radiation thermometers.

<https://standards.iteh.ai/catalog/standards/sist/79c08c9a3137/astm-e452-022023>

7.1.10 A metal clamp (*B*) containing a small screw is used to make a mechanical connection between the test thermocouple and the extension wires. Care should be taken to eliminate any temperature gradients that might exist along the metal clamps during furnace operation. Such gradients can cause extraneous emfs in the measuring circuit.

7.1.11 Fig. 12 shows the same type of seal as Fig. 10 but with a Type 2 thermocouple suspended into the test furnace instead of a Type 1. Fig. 13 shows a vacuum seal design that can be used to bring Type 3 or 4 thermocouple assemblies into the furnace.

7.1.12 In general, any sealing unit that is used to bring thermocouple assemblies into a furnace chamber should (1) allow the thermocouple assembly to be easily installed or removed from the furnace, (2) electrically insulate the thermoelements from each other and from any part of the furnace that is connected electrically to the furnace power supply, (3) not cause any physical or chemical changes in the thermoelements, and (4) not introduce any extraneous emfs in the thermocouple-emf measuring circuit.

7.2 Radiation Thermometer:

7.2.1 A well characterized and stable radiation thermometer, with a calibration of known uncertainty, is used as the standard instrument for determining temperatures in this test method. The radiation thermometer can be either the disappearing filament type or the automatic type, depending on the accuracy required for a specific test. (See Table 1 for calibration uncertainties.) Both types of radiation thermometers are available commercially. If something other than a disappearing filament pyrometer is used, it shall have an operating wavelength less than or equal to 1.1 μm and meet both the temperature measurement and sighting field of view requirements of the calibration apparatus. (Refer to Test Method E1256 for methods to determine the target characteristics of an automatic radiation thermometer in addition to the sighting cautions illustrated in Figs. 8 and 9 herein.) For radiation thermometers with significant spectral response at wavelengths that differ by more than 40 nm from the center wavelength of the instrument, significant errors may be introduced if the calibration of the radiation thermometer was not performed