



Designation: **G90–17** G90–23

Standard Practice for Performing Accelerated Outdoor Weathering of Materials Using Concentrated Natural Sunlight¹

This standard is issued under the fixed designation G90; the number immediately following the designation indicates the year of original adoption or, in the case of revision, the year of last revision. A number in parentheses indicates the year of last reapproval. A superscript epsilon (ϵ) indicates an editorial change since the last revision or reapproval.

1. Scope-Scope*

1.1 ~~Fresnel-reflecting-Linear~~ Fresnel reflector concentrators using the sun as source are utilized in the accelerated outdoor exposure testing of materials.

1.2 This practice covers a procedure for performing accelerated outdoor exposure testing of materials using a ~~Fresnel-reflecting-Linear~~ Fresnel reflector linear Fresnel reflector, accelerated outdoor weathering, test machine. The apparatus (see Fig. 1 and Fig. 2) and guidelines are described herein to minimize the variables encountered during outdoor accelerated exposure testing.

1.3 This practice does not specify the exposure conditions best suited for the materials to be tested but is limited to the method of obtaining, measuring, and controlling the procedures and certain conditions of the exposure. Sample preparation, test conditions, and evaluation of results are covered in existing methods or specifications for specific materials.

1.4 The ~~Fresnel-reflecting-Linear~~ Fresnel reflector accelerated outdoor exposure test ~~machines~~ apparatus described may be suitable for the determination of the relative durability of materials when these materials are exposed to concentrated sunlight, heat, and moisture, provided the mechanisms of chemical or physical change, or both, which control the acceleration factors for the materials do not differ significantly moisture.

1.5 This practice establishes uniform sample mounting and in-test maintenance procedures. Also included in the practice are standard provisions for maintenance of the machine and ~~Fresnel-reflecting-Linear~~ Fresnel reflector linear Fresnel reflector mirrors to ensure cleanliness and durability.

1.6 This practice shall apply to specimens whose size meets the dimensions of the target board as described in 8.2.

1.7 For test machines currently in use, this practice ~~may not apply to~~ is not recommended for specimens exceeding 13 mm (1/2 in.) in thickness because ~~cooling may be questionable~~ of specimen cooling.

1.8 Values stated in SI units are to be regarded as the standard. The inch-pound units in parentheses are provided for information only.

1.9 *This standard does not purport to address all of the safety concerns, if any, associated with its use. It is the responsibility of the user of this standard to establish appropriate safety, health, and environmental practices and determine the applicability of regulatory limitations prior to use.*

¹ This practice is under the jurisdiction of ASTM Committee G03 on Weathering and Durability and is the direct responsibility of Subcommittee G03.02 on Natural and Environmental Exposure Tests.

Current edition approved Dec. 1, 2017; July 1, 2023. Published December 2017; August 2023. Originally approved in 1985. Last previous edition approved in 2010 as G90–10; G90–17. DOI: 10.1520/G0090-17; 10.1520/G0090-23.

*A Summary of Changes section appears at the end of this standard

- | | |
|--------------------------|-----------------------------|
| A - AIR PLENUM | H - MAST, AZIMUTH ADJUST |
| B - AIR BLOWER | I - AIR FLOW SWITCH |
| C - ROTOR ASSEMBLY | J - WATER SPRAY NOZZLE |
| D - AIR DEFLECTOR | K - CLUTCH DISC, ELEV DRIVE |
| E - A-FRAME ASSEMBLY | L - SOLAR CELLS/SHADOW HAT |
| F - MIRROR | M - SAMPLE PROTECTION DOOR |
| G - GEAR BOX, ELEV DRIVE | N - DOOR RELEASE MECHANISM |

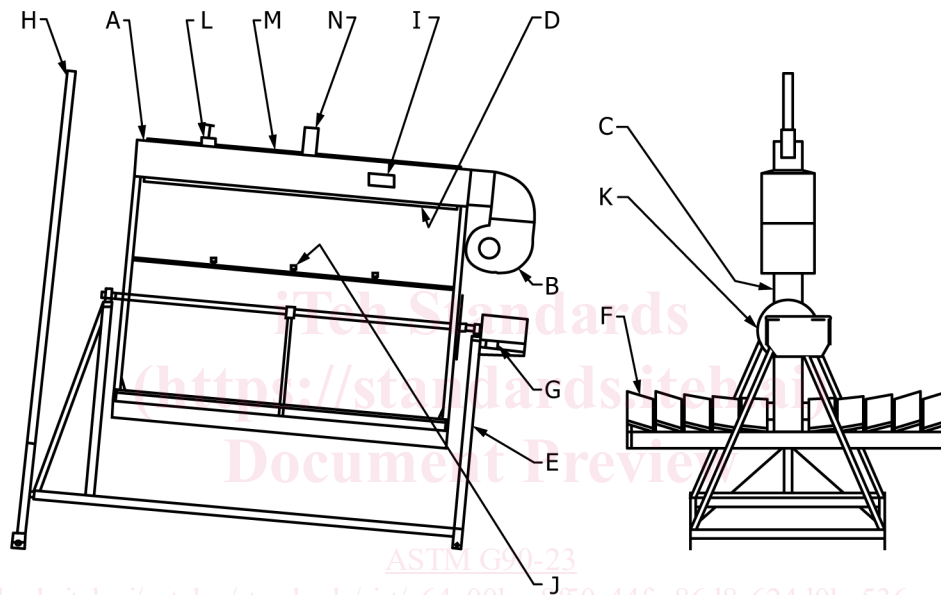

FIG. 1 Schematic of Fresnel-Reflecting-Linear Fresnel Reflector Concentrator Accelerated Weathering Machine Single Axis Tracking

1.10 This international standard was developed in accordance with internationally recognized principles on standardization established in the Decision on Principles for the Development of International Standards, Guides and Recommendations issued by the World Trade Organization Technical Barriers to Trade (TBT) Committee.

2. Referenced Documents

2.1 ASTM Standards:²

- D859 Test Method for Silica in Water
- D1014 Practice for Conducting Exterior Exposure Tests of Paints and Coatings on Metal Substrates
- D1435 Practice for Outdoor Weathering of Plastics
- D1898 Practice for Sampling of Plastics (Withdrawn 1998)³
- D4141 Practice for Conducting Black Box and Solar Concentrating Exposures of Coatings
- D4364 Practice for Performing Outdoor Accelerated Weathering Tests of Plastics Using Concentrated Sunlight
- D4517 Test Method for Low-Level Total Silica in High-Purity Water by Flameless Atomic Absorption Spectroscopy
- D5722 Practice for Performing Accelerated Outdoor Weathering of Factory-Coated Embossed Hardboard Using Concentrated Natural Sunlight and a Soak-Freeze-Thaw Procedure

² For referenced ASTM standards, visit the ASTM website, www.astm.org, or contact ASTM Customer Service at service@astm.org. For *Annual Book of ASTM Standards* volume information, refer to the standard's Document Summary page on the ASTM website.

³ The last approved version of this historical standard is referenced on www.astm.org.

- | | |
|--------------------------|-----------------------------|
| A - AIR PLENUM | I - GEAR BOX, AZIMUTH DRIVE |
| B - AIR BLOWER | J - AIR FLOW SWITCH |
| C - ROTOR ASSEMBLY | K - WATER SPRAY NOZZLE |
| D - TURN TABLE ASSEMBLY | L - CLUTCH DISC, ELEV DRIVE |
| E - A-FRAME ASSEMBLY | M - SOLAR CELLS/SHADOW HAT |
| F - MIRROR | N - SAMPLE PROTECTION DOOR |
| G - GEAR BOX, ELEV DRIVE | O - DOOR RELEASE MECHANISM |
| H - CONTROL BOX | P - AIR DEFLECTOR |

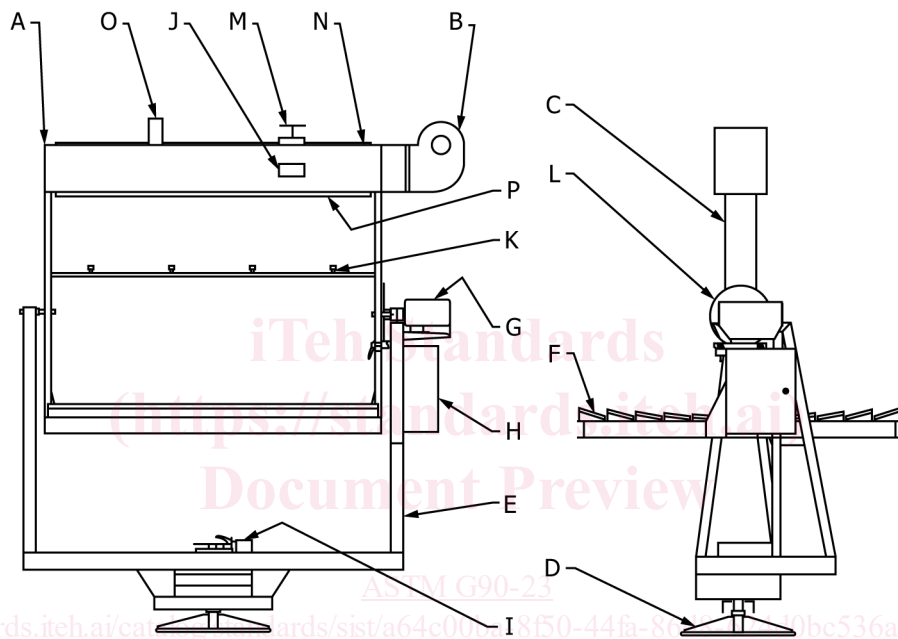

FIG. 2 Dual Axis Tracking

- [E816 Test Method for Calibration of Pyrheliometers by Comparison to Reference Pyrheliometers](#)
- [E824 Test Method for Transfer of Calibration From Reference to Field Radiometers](#)
- [E903 Test Method for Solar Absorptance, Reflectance, and Transmittance of Materials Using Integrating Spheres](#)
- [G7 Practice for Natural Weathering of Materials](#)
- [G24 Practice for Conducting Exposures to Daylight Filtered Through Glass](#)
- [G113 Terminology Relating to Natural and Artificial Weathering Tests of Nonmetallic Materials](#)
- [G130 Test Method for Calibration of Narrow- and Broad-Band Ultraviolet Radiometers Using a Spectroradiometer](#)
- [G167 Test Method for Calibration of a Pyranometer Using a Pyrheliometer](#)
- [G169 Guide for Application of Basic Statistical Methods to Weathering Tests](#)
- [G173 Tables for Reference Solar Spectral Irradiances: Direct Normal and Hemispherical on 37° Tilted Surface](#)
- [G179 Specification for Metal Black Panel and White Panel Temperature Devices for Natural Weathering Tests](#)
- 2.2 *Other Standards:*
 - [SAE J576 Plastic Materials for Use in Optical Parts Such as Lenses and Reflectors of Motor Vehicle Lighting Devices](#)⁴
 - [SAE J1961 Accelerated Exposure of Automotive Exterior Materials Using A Solar Fresnel Reflector Apparatus](#)
 - [WMO Guide to Meteorological Instruments and Methods of Observation WMO No. 8, Fifth Edition](#)⁵

⁴ Available from SAE International (SAE), 400 Commonwealth Dr., Warrendale, PA 15096-0001, <http://www.sae.org>.

⁵ Available from World Meteorological Organization, Geneva, Switzerland.

2.3 ISO Standards:⁶

[ISO 4892-1 Plastics— Methods of Exposure to Laboratory Light Sources—Part 1: General Guidance](#)

[ISO 9060 \(2018\) Specification and Classification of Instruments for Measuring Hemispherical Solar and Direct Solar Radiation](#)

3. Terminology

3.1 ~~Definitions~~Definitions:—Definitions

~~3.1.1 Definitions of terms common to G03 durability standards can be found in Terminology G113.~~ ~~of terms common to G03 durability standards can be found in Terminology G113.~~

3.2 Definitions of Terms Specific to This Standard:

3.2.1 linear Fresnel reflector, n—an array of long narrow segments of mirrors to concentrate sunlight onto a fixed receiver located at a common focal point of the reflectors.

4. Significance and Use

4.1 Results obtained from this practice can be used to compare the relative durability of materials subjected to the specific test cycle used. ~~No accelerated test can be specified as a perfect simulation of natural or field exposures.~~ Results obtained from this practice can be considered as representative of natural weathering only when ~~the degree of comparative performance has been established for the specific materials being tested.~~ a sufficient magnitude of mathematical correlation exists between exposures.

4.2 The acceleration factor relating the rate of degradation in this accelerated exposure to the rate of degradation in a natural weathering exposure varies with the type and formulation of the material. Each material and formulation may respond differently to the increased level of irradiance and differences in temperature and humidity. Thus an acceleration factor determined for one material may not be applicable to other materials. For this reason, the use of a single acceleration factor is not recommended. Also, a different acceleration factor may be obtained by using different mirror types and configurations. Because of variability in test results for both accelerated and natural weathering exposures, results from a sufficient number of tests must be obtained to determine an acceleration factor for a material. Further, the acceleration factor is applicable to only one exposure location because results from natural weathering will vary due to seasonal or annual differences in climatic factors.

4.3 The relative durability of materials determined by this practice can be used to determine the relative durability of the materials exposed under natural weathering conditions provided the materials have similar acceleration factors. However, even if results from a specific accelerated test condition are found to be useful for comparing the durability of materials exposed in a particular exterior location, it cannot be assumed that they will be useful for determining the relative durability for a different location. The relative durability of materials in natural weathering exposure can be very different depending on the location of the exposure because of differences in important climatic factors, such as sunlight, time of wetness, temperature, pollutants, etc.

4.4 Variations in results may be expected when operating conditions vary within the limits of this practice.

~~4.5 Variations in results may be expected when operating conditions vary within the limits of this practice. For example, there can be large differences in the amount of degradation in a single material between separate, although supposedly identical, exposures carried out for the same duration or number of exposure cycles. This practice is best used to compare the relative performance of materials tested at the same time in the same fresnel-linear Fresnel reflector device. Because of possible variability between the same type of exposure device and variability in irradiance, temperature and moisture levels at different times, comparing the amount of degradation in materials exposed for the same duration or radiant energy at separatedifferent times is not recommended.~~

4.6 This practice should not be used to establish a “pass/fail” approval of materials after a specific period of exposure unless performance comparisons are made relative to a control material exposed simultaneously. It is strongly recommended that at least one control test specimen be exposed with each test. It is preferable to use two control test specimens, one with relatively good durability and one with relatively poor durability. Alternatively, the variability in the test can be defined so that statistically significant pass/fail judgements can be made.

4.7 The use of at least three replicates of each control test specimen and each material being evaluated is recommended. Consult Guide G169 for performing statistical analysis.

⁶ Available from International Organization for Standardization (ISO), ISO Central Secretariat, BIBC II, Chemin de Blandonnet 8, CP 401, 1214 Vernier, Geneva, Switzerland, <http://www.iso.org>.

5. Apparatus

5.1 *Test Machines*—Fresnel-reflector test machines used in Cycles 1, 2, and 3 of Linear Fresnel reflector test machines are equipped with a water delivery system to [Table 1](#) are nearly identical. The only difference between spray test specimens using the cycles specified in [Table 1](#) the machines is the addition of a water delivery system to the device used in Cycles 1 and 3. Use of the specific cycle should relate to end use of the material and should be agreed upon by all interested parties. Document the spray cycle in the test report.

5.1.1 The Fresnel-reflector-linear Fresnel reflector test machine is a follow-the-sun “follow-the-sun” apparatus having flat mirrors so positioned that the sun’s rays strike them at near-normal incident angles while in operation. The mirrors are arranged to simulate tangents to a parabolic trough in order to reflect sunlight uniformly onto the specimens in the target area (see [Fig. 1](#), [Fig. 2](#), and [Fig. 3](#)).

iTeh Standards
(<https://standards.itih.ai>)
Document Preview

ASTM G90-23

<https://standards.itih.ai/catalog/standards/sist/a64c00ba-8f50-44fa-86d8-624d0bc536aa/astm-g90-23>

TABLE 1 Fresnel-Reflector Test Machine Typical Spray Cycles

Cycle	Daytime			Nighttime		
	Spray Duration	Dry-Time Duration	Cycles/h	Spray Duration	Dry-Time Duration	Cycles/h
1	8 min	52 min	1	8 min	water is sprayed on the test specimens at: 9:00 p.m. 12:00 midnight 3:00 a.m. no water spray used	4 cycles per hour (from 7PM to 5 AM)
2 3 ^A		no water spray used no water spray used		3 min		

TABLE 1 Typical Spray Cycles for ASTM G90

Cycle	Daytime (during operation)			Nighttime (7 pm to 5 am)		
	Spray Duration	Dry-Time Duration	Cycles/hour	Spray Duration	Dry-Time Duration	Cycles/hour
1	8 min	52 min	1 cycle/hour	8 min	water is sprayed on specimens at: 9 pm, 12 midnight, and 3 am No water spray used	4 cycles/hour
2 3 ^A		No water spray used No water spray used		3 min		

^A This is the cycle specified in Procedure C of Practice [D4141](#).

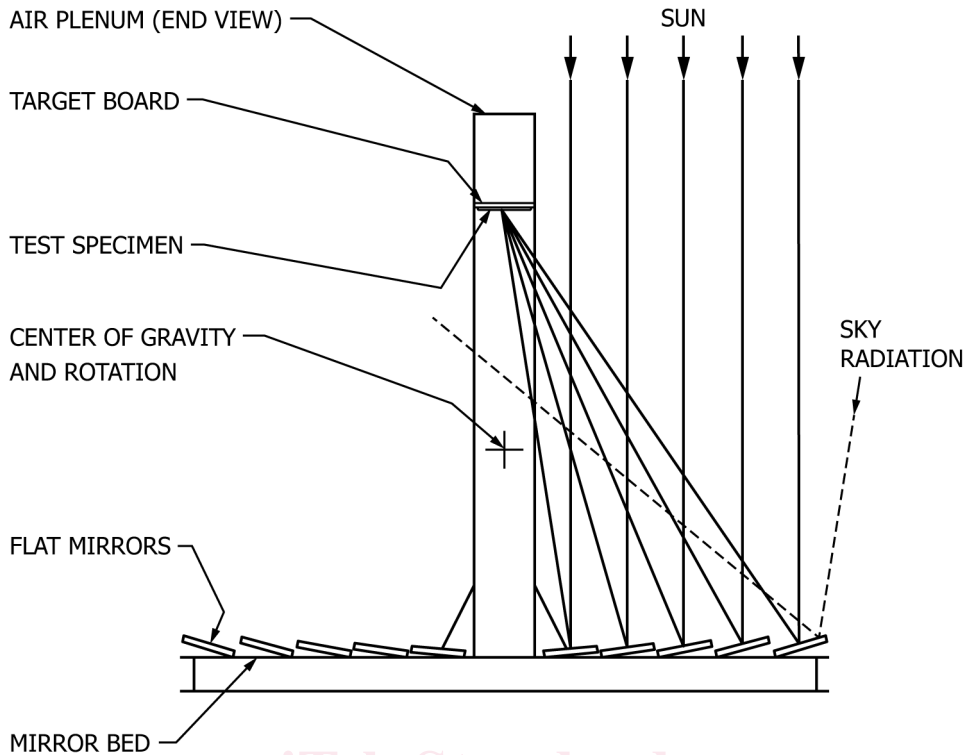

FIG. 3 Schematic of Optical System for a Linear Fresnel Reflecting Reflector Concentrator Accelerated Weathering Machine

5.2 Mirrors—The Fresnel-reflector system mirrors of typical machines currently in use have a typical specular, spectral reflectance curve such as that presented. Typical spectral reflectance values for mirrors commonly in use as a function of wavelength are shown in Fig. 4. Other If other mirror types and configurations may be used providing they are used, they shall meet the requirements

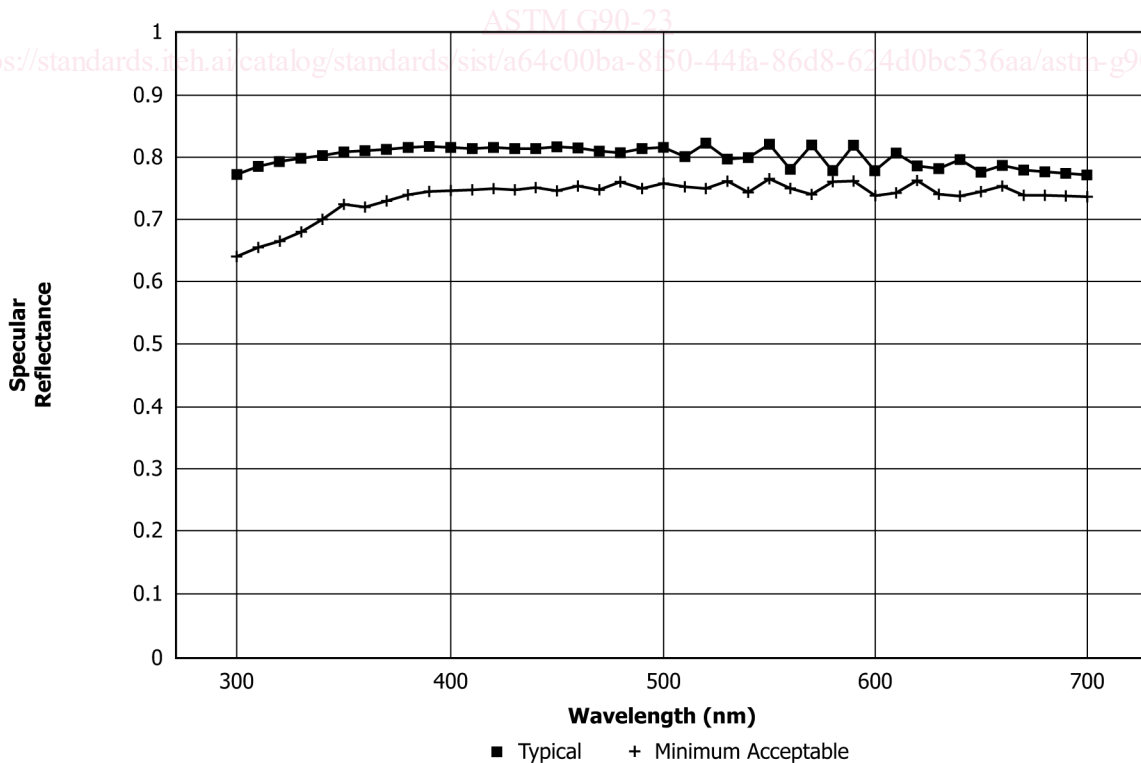

FIG. 4 Typical Specular Reflectance of Mirror Material

of 6.2.

5.3 *Photoreceptor Cells*—Two photoreceptor cells, such as silicon solar cells, are installed near the top of the air tunnel on the side facing the sun. A “T” shadow maker is mounted above the cells to illuminate equally one-half of each cell when the test machine is in proper focus. As one cell receives more radiation than the other, the balance is disturbed and a signal is furnished through an amplifier to a reversible motor which adjusts the machine to maintain focus.

5.4 *Tracking System*—The test machine shall be equipped with a system to keep the target area in focus throughout the day. Several options are possible.

5.4.1 Single-axis tracking with manual altitude adjustment (Fig. 1). The test machine’s axis is oriented in the north/south direction, with the north pole being altitude-adjustable to account for seasonable variations in solar altitude at zenith.

5.4.2 Dual axis tracking (Fig. 2). The test machine is equipped with two sets of photoreceptor cells, one to control the azimuth rotation of the machine, the other to control the tilt elevation. The axis of the target area remains parallel to the ground. The machine rotates about horizontal and vertical axes to keep the target area in focus.

5.5 *Temperature*—The test machine is equipped with a blower to cool the test specimens. The air is directed over the specimens by an adjustable deflector along one side of the target area. For unbacked mounting, air is also directed under the specimens. This limits the increase in surface temperatures of most specimens to 10°C above the maximum surface temperature that would be reached when identically mounted specimens are exposed to direct sunlight at normal incidence at the same time and location without concentration.

5.5.1 *Temperature Control*—Unless otherwise specified, if measurement of uninsulated black- or white-panel temperature is required, the panels shall be constructed, calibrated, and maintained according to Specification G179 except that the size shall be a minimum width of 50 mm by 125 mm. Unless otherwise specified, if measurement of insulated black- or white-panel temperature is required, the panels shall be constructed and maintained according to ISO 4892-1.

NOTE 1—If an insulated black-panel temperature is used, the temperature indicated will be higher than that indicated by an uninsulated black-panel thermometer under typical exposure conditions.

5.5.2 Typically, temperature of specimens is not controlled on solar concentrating test devices. Typical specimen temperatures obtained are likely to be greater than the temperature that would be experienced if the specimen were exposed to direct solar radiation at normal incidence (without concentration) at the same time. Temperature differences between exposures with and without concentration depend on the specimen absorptance and total coefficient of heat transfer, thickness, backing, and composition. During daytime exposures in solar concentrating test devices, variation in cloud cover may cause specimen temperatures to vary.

5.5.3 If control of specimen temperature is required, the temperature of an uninsulated or insulated black or white panel, or a specimen temperature may be monitored and used as an input to control specimen temperature by adjusting the speed of air blowing across the specimens. Other methods of temperature control may be used if agreed upon between concerned parties.

5.5.4 Temperatures during night time are typically not controlled.

5.6 *Nozzles*—The test machine used in Cycles 1 and 3 of Table 1 is provided with a nozzle assembly for spraying water onto the specimens during exposure. Fan spray nozzles which provide a uniform fine mist over the specimen area are recommended.

5.7 *Spray Orientation*—The apparatus shall be positioned so that specimens are sprayed at night either with specimens facing up or down.

5.7.1 *Specimens Face Down*—The apparatus is oriented with the mirrors below the target specimen area such that nozzles spray high purity water in an upward direction onto the specimens.

5.7.2 *Specimens Face Up*—The apparatus is oriented with the mirrors above the target specimen area such that nozzles spray high purity water in a downward direction onto the specimens.