



Designation: D4742 – 23

Standard Test Method for Oxidation Stability of Gasoline Automotive Engine Oils by Thin-Film Oxygen Uptake (TFOUT)¹

This standard is issued under the fixed designation D4742; the number immediately following the designation indicates the year of original adoption or, in the case of revision, the year of last revision. A number in parentheses indicates the year of last reapproval. A superscript epsilon (ϵ) indicates an editorial change since the last revision or reapproval.

1. Scope*

1.1 This test method evaluates the oxidation stability of engine oils for gasoline automotive engines. This test, run at 160 °C, utilizes a high pressure reactor pressurized with oxygen along with a metal catalyst package, a fuel catalyst, and water in a partial simulation of the conditions to which an oil may be subjected in a gasoline combustion engine. This test method can be used for engine oils with viscosity in the range from 4 mm²/s (cSt) to 21 mm²/s (cSt) at 100 °C, including re-refined oils.

1.2 This test method is not a substitute for the engine testing of an engine oil in established engine tests, such as Sequence IIID.

1.3 The values stated in SI units are to be regarded as standard. No other units of measurement are included in this standard.

1.3.1 *Exception*—Pressure units are provided in psig, and dimensions are provided in inches in **Annex A1**, because these are the industry accepted standard and the apparatus is built according to the figures shown.

1.4 *This standard does not purport to address all of the safety concerns, if any, associated with its use. It is the responsibility of the user of this standard to establish appropriate safety, health, and environmental practices and determine the applicability of regulatory limitations prior to use.* For specific warning statements, see Sections 7 and 8.

1.5 *This international standard was developed in accordance with internationally recognized principles on standardization established in the Decision on Principles for the Development of International Standards, Guides and Recommendations issued by the World Trade Organization Technical Barriers to Trade (TBT) Committee.*

¹ This test method is under the jurisdiction of ASTM Committee D02 on Petroleum Products, Liquid Fuels, and Lubricants and is the direct responsibility of Subcommittee D02.09.0G on Oxidation Testing of Engine Oils.

Current edition approved July 1, 2023. Published August 2023. Originally approved in 1988. Last previous edition approved in 2017 as D4742 – 17. DOI: 10.1520/D4742-23.

2. Referenced Documents

2.1 ASTM Standards:²

A314 Specification for Stainless Steel Billets and Bars for Forging

B211 Specification for Aluminum and Aluminum-Alloy Rolled or Cold-Finished Bar, Rod, and Wire (Metric) B0211_B0211M

D664 Test Method for Acid Number of Petroleum Products by Potentiometric Titration

D1193 Specification for Reagent Water

D2272 Test Method for Oxidation Stability of Steam Turbine Oils by Rotating Pressure Vessel

D4057 Practice for Manual Sampling of Petroleum and Petroleum Products

E1 Specification for ASTM Liquid-in-Glass Thermometers

3. Terminology

3.1 Definitions of Terms Specific to This Standard:

3.1.1 *break point, n*—the precise point of time at which rapid oxidation of the oil begins.

3.1.2 *oxidation induction time, n*—the time until the oil begins to oxidize at a relatively rapid rate as indicated by the decrease of oxygen pressure.

3.1.3 *oxygen uptake, n*—oxygen absorbed by oil as a result of oil oxidation.

4. Summary of Test Method

4.1 The test oil is mixed in a glass container with three other liquids that are used to simulate engine conditions: (1) an oxidized/nitrated fuel component (**Annex A2**), (2) a mixture of soluble metal naphthenates (lead, copper, iron, manganese, and stannous octoate (**Annex A3**)), and (3) Type I reagent water.

4.2 The glass container holding the oil mixture is placed in a high pressure reactor equipped with a pressure gauge. The high pressure reactor is sealed, charged with oxygen to a pressure of 620 kPa (90 psig), and placed in an oil or dry

² For referenced ASTM standards, visit the ASTM website, www.astm.org, or contact ASTM Customer Service at service@astm.org. For *Annual Book of ASTM Standards* volume information, refer to the standard's Document Summary page on the ASTM website.

*A Summary of Changes section appears at the end of this standard

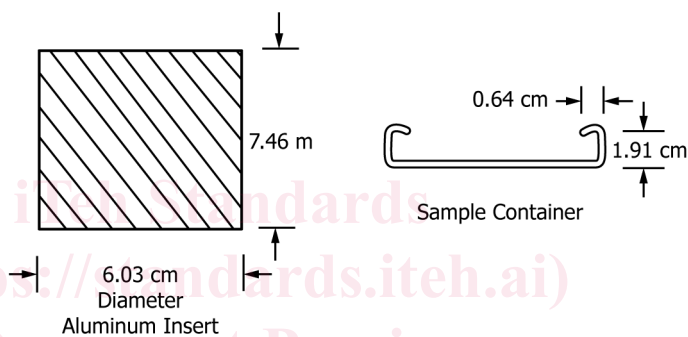
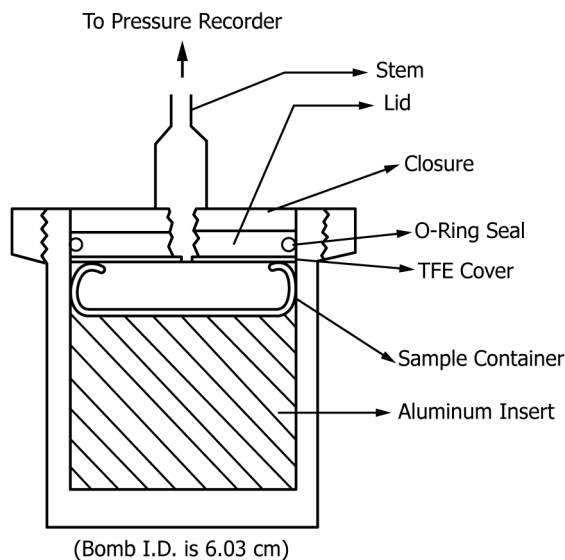

FIG. 1 Schematic Drawing of Oxidation Test Apparatus

bath^{3,4} at 160 °C at an angle of 30° from the horizontal. The high pressure reactor is rotated axially at a speed of 100 r/min forming a thin film of oil within the glass container resulting in a relatively large oil-oxygen contact area.

NOTE 1—A pressure sensing device can be used in place of a pressure gauge.

4.3 The pressure of the high pressure reactor is recorded continuously from the beginning of the test and the test is terminated when a rapid decrease of the high pressure reactor pressure is observed (Point B, Fig. A1.2). The period of time that elapses between the time when the high pressure reactor is placed in the oil or dry bath and the time at which the pressure begins to decrease rapidly is called the oxidation induction time and is used as a measure of the relative oil oxidation stability.

5. Significance and Use

5.1 This test method is used to evaluate oxidation stability of lubricating base oils with additives in the presence of chemistries similar to those found in gasoline engine service.

Test results on some ASTM reference oils have been found to correlate with sequence IIID engine test results in hours for a 375 % viscosity increase.⁵ The test does not constitute a substitute for engine testing, which measures wear, oxidation stability, volatility, and deposit control characteristics of lubricants. Properly interpreted, the test may provide input on the oxidation stability of lubricants under simulated engine chemistry.

5.2 This test method is intended to be used as a bench screening test and quality control tool for lubricating base oil manufacturing, especially for re-refined lubricating base oils. This test method is useful for quality control of oxidation stability of re-refined oils from batch to batch.

5.3 This test method is useful for screening formulated oils prior to engine tests. Within similar additive chemistry and base oil types, the ranking of oils in this test appears to be predictive of ranking in engine tests. When oils having completely different additive chemistry or base oil type are compared, oxidation stability results may not reflect the actual engine test result.

5.4 Other oxidation stability test methods have demonstrated that soluble metal catalyst supplies are very inconsistent

³ The sole source of supply of the catalyst and dry bath known to the committee at this time is Tannas Co., 4800 James Savage Rd., Midland, MI 48642.

⁴ If you are aware of alternative suppliers, please provide this information to ASTM International Headquarters. Your comments will receive careful consideration at a meeting of the responsible technical committee,¹ which you may attend.

⁵ Ku, C. S. and Hsu, S. M., "A Thin Film Uptake Test for the Evaluation of Automotive Lubricants," *Lubrication Engineering*, 40, 2, 1984, pp. 75-83.

INDUCTION TIME DETERMINATION

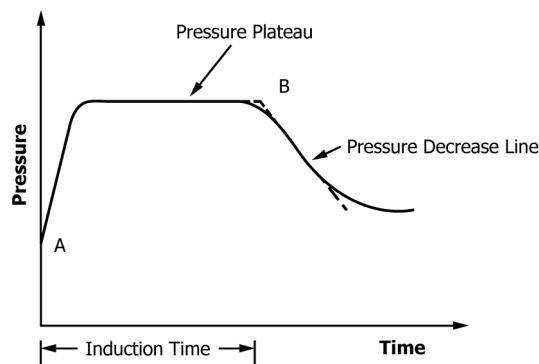

FIG. 2 Pressure versus Time Diagram of the Oxidation Test

and they have significant effects on the test results. Thus, for test comparisons, the same source and same batch of metal naphthenates shall be used.

NOTE 2—It is also recommended as a good research practice not to use different batches of the fuel component in test comparisons.

6. Apparatus

6.1 *High Pressure Reactor*, glass sample container, aluminum insert, pressure gauge, thermometer, test bath and accessories are shown in Fig. 2 and Fig. 3, and described in Annex A1.

NOTE 3—It is reported in literature⁵ that the oxidation high pressure reactor can be modified from the Test Method D2272 oxidation high pressure reactor by insertion of an aluminum cylinder.

6.2 *Precision Pressure Gauge*—A certified precision pressure gauge is used to accurately control the oxygen feed to the high pressure reactor. The gauge has a sufficient range to encompass 0 kPa to 650 kPa or more (~90 psig) required by the test method with division 2.0 kPa (~0.5 psig) or better to enable readings to be made to 2.0 kPa (~0.25 psig).

7. Reagents

7.1 *Purity of Reagents*—Reagent grade chemicals shall be used in all tests. Unless otherwise indicated, it is intended that all reagents shall conform to the specifications of the Committee on Analytical Reagents of the American Chemical Society.⁶

7.2 *Purity of Water*—Unless otherwise indicated, references to water shall be understood to mean distilled water meeting requirements of reagent water as defined by Type I of Specification D1193.

7.3 *Acetone*, CH₃COCH₃. (**Warning**—Extremely flammable. Irritating to skin, eyes, and mucous membranes.)

⁶ ACS Reagent Chemicals, Specifications and Procedures for Reagents and Standard-Grade Reference Materials, American Chemical Society, Washington, DC. For suggestions on the testing of reagents not listed by the American Chemical Society, see *Analar Standards for Laboratory Chemicals*, BDH Ltd., Poole, Dorset, U.K., and the *United States Pharmacopeia and National Formulary*, U.S. Pharmacopeial Convention, Inc. (USPC), Rockville, MD.

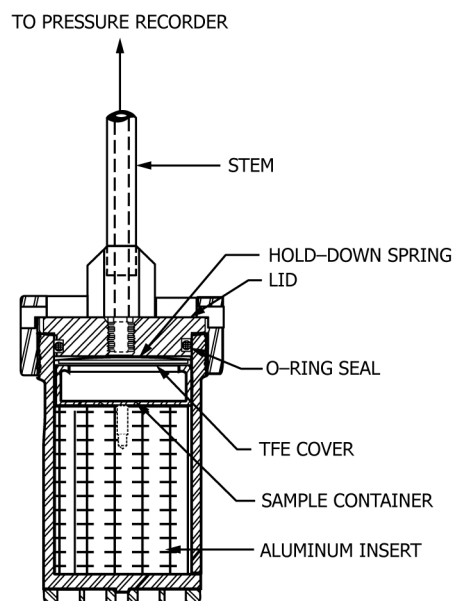

(HIGH PRESSURE REACTOR I.D. is 6.03 cm)

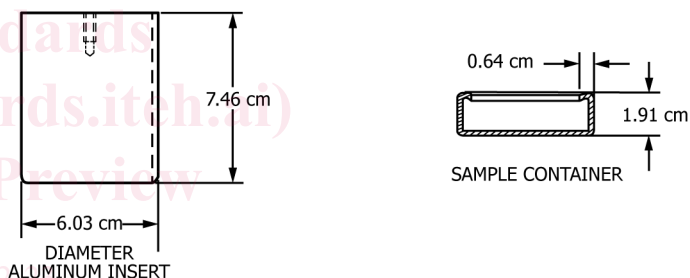

FIG. 3 Schematic Drawing of an Assembled Vessel, Aluminum Insert, and Glass Sample Container

7.4 *Hexane*, C₆H₁₄, Practical Grade or other suitable hydrocarbon solvent. (**Warning**—Extremely flammable. Harmful if inhaled. May produce nerve cell damage. Skin irritant on repeated contact. Aspiration hazard.)

7.5 *Isopropyl Alcohol*, CH₃CH(CH₃)OH. (**Warning**—Flammable. Eye irritant. Vapors narcotic.)

7.6 *Oxygen*. (**Warning**—Oxygen vigorously accelerates combustion.)

7.7 *Potassium Hydroxide*, Alcohol Solution (1.5%)—Dissolve 12 g of potassium hydroxide (KOH) pellets in 1 L of 99 % isopropyl alcohol. (**Warning**—Potassium hydroxide is corrosive.)

8. Materials

8.1 *Fuel Component*—The fuel component is intended to simulate an oxidized nitrated gasoline fraction. This component may be prepared in accordance with the procedures described in Annex A2. (See 8.2 and Note 4.) (**Warning**—Fuel component is extremely flammable. Vapors harmful if inhaled. Skin irritant on repeated contact. Aspiration hazard.)

8.2 *Soluble Metal Catalyst Mixture*—This catalyst^{3,4} is a mixture of soluble metal catalysts (lead, copper, iron, manganese, and tin). The catalyst may be prepared according to the procedures described in [Annex A3](#). (See [8.2](#) and [Note 4](#).) (**Warning**—Lead and manganese naphthenates are known to be poisonous, but all naphthenates should be handled with care. Naphthenates are also flammable.)

NOTE 4—With some catalyst chemicals, reactivity can be a problem. This can be curtailed by storing in a refrigerator at approximately 5 °C. The catalyst chemicals remain effective up to six months after the septum is punctured if they are stored as noted above.

NOTE 5—It is recommended that each new batch of fuel or metal catalyst be correlated with a standard reference oil, in accordance with good laboratory practices.

8.3 *Liquid Detergent (Industrial Strength)*.

8.4 *Silicone Stopcock Grease*.

9. Preparation of Apparatus

9.1 *Glass Sample Container*—Rinse the glass sample container with hexane or other suitable hydrocarbon solvent. Clean the glass container with hot detergent solution and water. Rinse the container with acetone. Blow the container dry with clean compressed air.

NOTE 6—A clean glass sample container is important for obtaining repeatable results. Thorough cleaning of the glass sample can be accomplished by (1) hexane rinse, (2) acetone soak for 15 min, (3) hot detergent solution and water soak for 4 h, (4) acetone rinse, and (5) hexane rinse. A clean glass sample container is important for obtaining repeatable results.

NOTE 7—A segmented glass sample container has been found suitable to prevent premature mixing of the catalyst components.

9.2 *Cleaning of High Pressure Reactor*—Wash the inside of the high pressure reactor, aluminum insert, lid, and inside with hot detergent solution and water. Rinse the inside of the stem with isopropyl alcohol and blow dry with clean compressed air. If the high pressure reactor, insert, lid, or inside of the stem emits acidic odor after simple cleaning, wash with a solution of alcoholic potassium hydroxide (KOH) of 1.5 %, and repeat the cleaning procedures. For dry baths, refer to manufacturer's manuals for details.

9.3 *Cleaning of High Pressure Reactor Stem*—It is recommended to periodically disassemble, inspect, and clean the high pressure reactor stem. Rinse the inside of the stem with isopropyl alcohol and blow dry with clean compressed air. After cleansing, it is recommended to insert a dry pipe cleaner into the transducer line opening for removal of potential residue buildup.

NOTE 8—It is recommended to replace the O-rings when reassembling the pressure transducers.

9.4 To obtain a representative sample of stocks of uniform petroleum products, follow Practice [D4057](#).

9.5 *Cleaning of Catalyst Syringes*—Individual catalyst syringes are to be used for each catalyst component. They are to be thoroughly cleaned and dried prior to each use. (See [Annex A4](#) for recommended procedure.)

10. Procedure

10.1 *Weighing and Mixing Sample and Catalyst Components*:

10.1.1 Weigh the clean glass sample container to the nearest mg.

10.1.2 Weigh 1.500 g ± 0.001 g of oil sample into the container.

10.1.3 Add 0.050 g ± 0.001 g each of both the fuel component and the soluble metal catalyst mixture.

10.1.4 Add 0.030 g ± 0.001 g of distilled water (Type I) to the glass sample container.

10.1.5 Just prior to inserting the glass sample container into the high pressure reactor, thoroughly mix the catalyst components within the sample container by hand-rotation (approximately five rotations) and proceed immediately to [10.2](#). Delay may result in variation of results.

10.2 *High Pressure Reactor Charging and Assembly*—Immediately and rapidly assemble the high pressure reactor as shown in [Fig. 1](#) and [Fig. 2](#). Refer to manufacturer's manual for details.

10.2.1 Put the aluminum insert into the high pressure reactor followed by the glass sample container and the TFE (tetra-fluoroethylene) plastic cover disk.

10.2.2 Place the stainless hold-down spring on top of the TFE disk and the glass sample container.

NOTE 9—The stainless steel hold-down spring not only holds down the TFE cover disk but, more importantly, prevents the glass sample container from slipping inside the high pressure reactor with consequent poor results.

10.2.3 Apply a thin coating of silicone stopcock grease to the O-ring high pressure reactor seal located in the gasket groove of the high pressure reactor lid to provide lubrication.

10.2.4 Insert the lid into the high pressure reactor.

10.2.5 Place and tighten the cap on the high pressure reactor to lock down the lid in the high pressure reactor.

10.2.6 Attach the high pressure oxygen hose and purge the high pressure reactor twice at about 620 kPa (90 psig) of oxygen to remove the air originally present in the high pressure reactor.

NOTE 10—It is advisable to avoid releasing the oxygen too rapidly by decreasing the pressure to atmospheric in no less than one minute to avoid possible foaming and overflow of the sample from the glass sample container.

10.2.7 Charge the high pressure reactor to 620 kPa (90 psig) oxygen at 21 °C using an in-line precision pressure gauge to monitor the high pressure reactor pressure with 1 kPa (0.12 psig). (For ambient temperatures other than 21 °C, increase (or decrease) the initial pressure by 2.5 kPa (0.4 psig) for each 1 °C above (or below) 21 °C.)

10.2.8 Fill the high pressure reactor to the required pressure and close the inlet valve. Test the high pressure reactor for leaks by immersing in water or by using soap solution.

10.3 *Oxidation*—Before starting the test, bring the heating bath to the test temperature at 160 °C while the stirrer is in operation. (This can be done during preparation of the sample and the high pressure reactor.)

10.3.1 Switch off the stirrer and insert the high pressure reactor into the carriages. Note the time, and restart the stirrer.

NOTE 11—The time for the bath to reach the operating temperature after insertion of the high pressure reactor may differ for different apparatus

assemblies and should be observed for each unit (a unit may carry one, two, three, or four high pressure reactors). The objective is to find a set of conditions which does not permit a drop of more than 2 °C after insertion of the high pressure reactor(s) and allows the high pressure reactor pressure to reach plateau within 15 min.

10.3.2 If an auxiliary heater is used, keep it on for the first 5 min of the run and then turn it off (Note 11).

10.3.3 Allow the bath temperature to level out at the test temperature which must occur within 15 min after insertion of the high pressure vessel. Maintaining the test temperature within the specified limits of 160 °C ± 0.3 °C during the entire test run is the most important single factor assuring both repeatability and reproducibility of test results. If the test temperature cannot be maintained as specified, the test results should not be considered valid.

10.4 Keep the high pressure reactor completely submerged and maintain continuous and uniform rotation throughout the test. A standard rotational speed of 100 r/min ± 5 r/min is required; any appreciable variations in this speed could cause erratic results.

10.5 Monitor the pressure of the high pressure reactor. If a dial pressure gauge is used, make readings at least every 5 min. (The maximum pressure must be reached within 15 min.) After a test period (the induction time), the pressure decreases because of oxygen absorption by oil (the break point).

10.5.1 When the oil reaches the break point, the pressure decreases rapidly. The test can be terminated as soon as sufficient information has been collected to form a tangent to the decreasing pressure trace (see 10.6) or, if desired, continued until pressure decreases to some further level.

NOTE 12—The pressure within the high pressure reactor increases at the beginning because of gas expansion accompanying the temperature increase of the high pressure reactor. Following this rise, the pressure reaches a plateau as shown in Fig. A1.2. This pressure may gradually drop slightly during the test. A gradual decrease of the pressure is not unusual and does not invalidate the test.

NOTE 13—If a break in pressure does not occur within 300 min to 500 min, the operator may elect to terminate the test. A slow decrease in pressure may result from a leak in the reactor or a very gradual oxidation process.

10.6 Record the time at which the pressure starts to decrease rapidly at the break point (Point B, Fig. A1.2), which is marked as the intersection of the tangent of the pressure plateau line during the final 20 min before the break point and the tangent of the pressure decrease line following the break point as shown in Fig. A1.2.

11. Report

11.1 Report the oxidation induction time in min. Determine the induction time as the time period from the beginning of the test (Point A, Fig. A1.2) to the break point (Point B, Fig. A1.2).

12. Precision and Bias

12.1 The precision of this test method, as determined by statistical examination of interlaboratory results on break point time, is as follows:

12.1.1 *Repeatability*—The difference between successive results, obtained by the same operator with the same apparatus under constant operating conditions on identical test material, would in the long run, in the normal and correct operation of the test method, exceed the following values only in one case in twenty:

$$0.10 (x + 5 \text{ min}) \quad (1)$$

where:

x = the mean replicate runs in min

12.1.2 *Reproducibility*—The difference between two single and independent results obtained by different operators working in different laboratories on identical test material would, in the long run, in the normal and correct operation of the test method, exceed the following values only in one case in twenty:

$$0.22 (x + 5 \text{ min}) \quad (2)$$

where:

x = the mean of results obtained, in min, by two different laboratories.

12.2 *Bias*—No information can be presented on the bias of the procedure in this test method for measuring oxidation stability because no material having an accepted reference value is available.

12.3 The precision statements in 12.1.1 and 12.1.2 were determined from an interlaboratory study using the same batch of soluble metal mixture (Standard Reference Material SRM 1817 of the NIST) (see Note 14).

NOTE 14—The mixture was prepared using metal naphthenates from the specified batch number of the supplier: lead naphthenate (#101882), ferric naphthenate (#7124), cupric naphthenate (#72775), manganese naphthenate (#25296), and stannous naphthenate (#32519-A).

NOTE 15—The supporting test data from five cooperating laboratories are shown in Appendix X1. A research report including the raw data and the statistical treatment of data is available.⁷ A research report is available for dry bath equivalence.⁸

13. Keywords

13.1 oxidation stability; oxygen uptake; sequence IIID engine simulation; TFOUT

⁷ Supporting data have been filed at ASTM International Headquarters and may be obtained by requesting Research Report RR:D02-1202. Contact ASTM Customer Service at service@astm.org.

⁸ Supporting data have been filed at ASTM International Headquarters and may be obtained by requesting Research Report RR:D02-1836. Contact ASTM Customer Service at service@astm.org.

ANNEXES

(Mandatory Information)

A1. APPARATUS FOR THIN-FILM OXYGEN UPTAKE TEST

A1.1 *High Pressure Reactor*, with lid, cap, and stem is constructed as shown in Fig. A1.1. The high pressure reactor has the same dimensional specifications as the RBOT high pressure reactor (see Test Method D2272). Therefore, the high pressure reactor for RBOT can be used for this test. However, in the test an aluminum insert and a glass sample container, as specified in A1.2 and A1.3, respectively, are to be used.

A1.1.1 *High Pressure Reactor Body and Lid*, made of 303 stainless steel (see Specification A314). The high pressure reactor body is to be machined from 76.2 mm (3 in.) solid stainless steel. The interior surface shall be given a smooth finish to facilitate cleaning.

A1.1.2 *High Pressure Reactor Stem*, constructed of 303 stainless steel, the stem having an inside diameter of 6.4 mm (0.25 in.) and equipped with a 6.4 mm needle valve. The stem is connected to the center of the lid as shown in Fig. A1.1.

A1.1.3 *High Pressure Reactor Cap (or Closure Ring)*, made of chrome-plated steel.

A1.1.4 Test the high-pressure vessel for 1 h under a pressure of 3450 kPa (500 psi - 200 % of the maximum pressure in the Thin-Film Oxygen Uptake Test). Measure the outside diameter and the length of the vessel using a caliper before and after the test. If these are not within 0.25 mm (0.01 in.) of the original dimension when the pressure is released, reject the high-pressure vessel as unsafe. Also reject if the high-pressure vessel appears to be cracked or fractured. After repeated uses (approximately 500 tests), retest the high-pressure vessel at the above specifications to ensure safe operation.

A1.1.5 *O-ring Gaskets*, silicone or a fluorinated elastomer, 50.8 mm (2.0 in.) inside diameter by 60.3 mm (2.375 in.) outside diameter.

A1.2 *Aluminum Insert*, in Fig. A1.1, is made of 2024 aluminum rod (see Specification B211) with 60.3 mm in diameter and 74.6 mm in height.

A1.3 *Glass Sample Container*, in Fig. A1.1, is constructed of borosilicate glass.

A1.3.1 Cover the top of the sample container with a 57.2 mm (2.25 in.) diameter TFE-fluorocarbon disk with a 3.2 mm (0.125 in.) diameter hole in the center. The TFE cover prevents sample splash during vessel charge. The disk shall have a thickness of 0.8 mm (0.03152 in.). As an added safeguard against the occurrence of rotational differences between the glass sample container and high pressure vessel, a hold-down spring is required.

A1.3.2 The glass sample container shall have a sliding fit in the high pressure reactor with no excess side clearance. The container alone is to have a maximum wall thickness of 2.5 mm.

A1.4 *Gauge*, recording, as shown in Fig. A1.2, or indicating, with a range from 0 kPa to 1400 kPa (~ 200 psi) and graduated in 25 kPa (5 psi) divisions.

A1.4.1 The accuracy must be 2 % or less of the total scale interval.

A1.4.2 Mount recording gauges so that their faces are perpendicular to the axis of rotation.

NOTE A1.1—Clock-wound, round chart recorders should be periodically checked for constancy of the clock works and agreement with standard time.

A1.5 *Oxidation Bath*, equipped with an efficient stirring ability and with a suitable device for holding and rotating the high pressure reactor axially at an angle of 30° at 100 r/min \pm 5 r/min while submerged in oil or dry bath to a point at least 25.4 mm (1 in.). For liquid baths, the chamber must be held below the level of the bath liquid. Keep the oil level at 50.8 mm (2 in.) below the bath cover.

NOTE A1.2—It is recommended that the liquid bath be operated in a hood and the dry bath with at least a snorkel.

A1.5.1 A liquid bath must be at least 229 mm (9 in.) deep, filled with 30 L (8 gal) of heavy bath oil per high pressure reactor (petroleum or synthetic oil having a flash point greater than 250 °C). A dry bath must provide thorough heating around the sample and still turn at 100 r/min.

A1.5.2 Provide thermal regulation to maintain the liquid bath within ± 0.3 °C of the test temperature for a period as long as 8 h. There shall be sufficient heat immediately available to bring the high pressure vessels to operating temperature of 160 °C within 15 min.

A1.6 *Thermometer*, digital or liquid-in-glass styles shall be used to check the bath temperature monthly (or more often if necessary). The thermometer shall be able to be read with an accuracy of ± 0.1 °C at the level of 160 °C. Thermometers, digital or analog, need to be checked for accuracy at least one time per year. If using the ASTM Solvents Distillation 102C-86 thermometer, then use as prescribed in Specification E1. Refer to manufacturer's manuals for details.

NOTE A1.3—A monthly calibration of the bath fluid temperature device using a calibrated liquid-in-glass or DCT thermometer is recommended.

